

Application Bulletin

AB-26

Using Other Voltages with the FAN5063

Ron Lenk, Senior Staff Applications Engineer

7/16/01

Summary

The FAN5063 ACPI controller can be used with voltages other than those shown on the datasheet. A circuit using 3.3V to generate memory power is shown. It requires 12V for a gate drive voltage.

Using 3.3V Main to Generate Memory Power

For some applications, the FAN5063 ACPI controller may be used in a system without 5V power. In such a system, it is desirable to derive memory power from 3.3V, instead of the 5V shown in the FAN5063 datasheet.

The circuit shown in Figure 1 shows the portion of a FAN5063 circuit that accomplishes this.

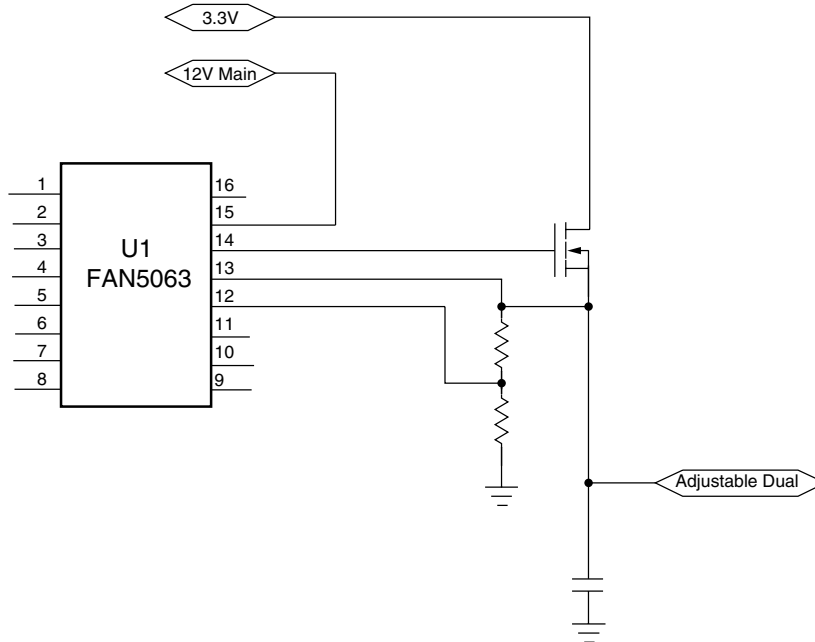

Figure 1 Using 3.3 Main to Power Memory

The FAN5063 powers a MOSFET whose drain is connected to the 3.3V. The output voltage is set, as usual, by the resistor divider feedback; it can for example be 2.5V (in which case the MOSFET acts as a linear regulator) or 3.3V (in which case the MOSFET acts as a switch). In either case, though, 3.3V cannot drive the gate, as this would provide no voltage for the gate-source junction. Instead, 12V is applied to pin 15 of the FAN5063, and this provides up to approximately 12V to the gate, with the exact voltage level being determined by the current requirements of the load.

Since the 12V is driving a gate, there is no power dissipation in the FAN5063. Note that this technique should NOT be used with a bipolar transistor, as this might result in excess heating of the IC. The only drawback of the circuit of Figure 1 is that the body diode of the MOSFET is configured in such a way that it is possible for the internal transistor (that powers the memory in S3) to backfeed the 3.3V. As long as this possibility is accounted for (for example by using 3.3V Standby or Dual for the drain) this circuit works well.

DISCLAIMER

FAIRCHILD SEMICONDUCTOR RESERVES THE RIGHT TO MAKE CHANGES WITHOUT FURTHER NOTICE TO ANY PRODUCTS HEREIN TO IMPROVE RELIABILITY, FUNCTION OR DESIGN. FAIRCHILD DOES NOT ASSUME ANY LIABILITY ARISING OUT OF THE APPLICATION OR USE OF ANY PRODUCT OR CIRCUIT DESCRIBED HEREIN; NEITHER DOES IT CONVEY ANY LICENSE UNDER ITS PATENT RIGHTS, NOR THE RIGHTS OF OTHERS.

LIFE SUPPORT POLICY

FAIRCHILD'S PRODUCTS ARE NOT AUTHORIZED FOR USE AS CRITICAL COMPONENTS IN LIFE SUPPORT DEVICES OR SYSTEMS WITHOUT THE EXPRESS WRITTEN APPROVAL OF THE PRESIDENT OF FAIRCHILD SEMICONDUCTOR CORPORATION. As used herein:

1. Life support devices or systems are devices or systems which, (a) are intended for surgical implant into the body, or (b) support or sustain life, or (c) whose failure to perform when properly used in accordance with instructions for use provided in the labeling, can be reasonably expected to result in significant injury to the user.
2. A critical component is any component of a life support device or system whose failure to perform can be reasonably expected to cause the failure of the life support device or system, or to affect its safety or effectiveness.