

# Application Brief 42015

## Reconstruction Filter Selection for HDTV and VGA/Applications

### METHOD

The filtering requirements for HDTV and VGA CRT displays vary depending on the resolution of the image displayed and its refresh rate. The actual refresh rate of the display is not necessarily the same as the transmission rate of the frames of images. Some formats use a frame rate of 30Hz, but the display of those formats cannot be scanned onto the CRT at 30Hz. Excessive large area flicker would result. Such kinds of flicker can be seen on a PAL display with its brightness set high. To avoid this, the video will need to be stored in a frame buffer. This buffer already exists in the MPEG decoder of HDTV systems, so there is no cost penalty. The buffer is read out at twice the rate as the frame rate for 30Hz systems, thus producing a refresh rate of 60Hz. Similar things are done for the 24Hz frame rate formats to boost them to a 60Hz refresh rate. See Table 1.

Pixel clock rates for the output D/A converters can be roughly determined from the above table. But don't forget that the deflection system of a CRT display needs retrace time for the vertical and horizontal.

This retrace time can vary from one design of an HDTV set to another, as it only involves trade-offs between the frame buffer in the MPEG decoder and the CRT deflection system. Use or add 10% retrace time for the vertical and 20% for the horizontal. Adding to the above table results in Table 2.

For VGA work, see Table 3.

For reference, the cutoff frequencies of the ML6426 filter family are shown in Table 4.

| PIXELS | VERTICAL LINES | ASPECT RATIO | PICTURE TRANSMISSION RATE |
|--------|----------------|--------------|---------------------------|
| 1920   | 1080           | 16:9         | 60I, 30P, 24P             |
| 1280   | 720            | 16:9         | 60P, 30P, 24P             |
| 704    | 480            | 16:9 AND 4:3 | 60P, 60I, 30P,24P         |
| 640    | 480            | 4:3          | 60P, 60I, 30P,24P         |

P=progressive scan, I=interlaced scan

Table 1. HDTV Aspect Ratio

| PIXELS | VERTICAL LINES | PICTURE TRANSMISSION RATE** | DISPLAY REFRESH RATE** | APPROXIMATE HORIZONTAL RATE | APPROXIMATE SAMPLE CLOCK | APPROXIMATE RECONSTRUCTION FILTER CUTOFF | MICRO LINEAR PART NUMBER *** |
|--------|----------------|-----------------------------|------------------------|-----------------------------|--------------------------|--|------------------------------|
| 1920   | 1080           | 60I                         | 60Hz                   | 35.3kHz                     | 81MHZ                    | 40.5MHZ                                  | ML6426-6                     |
| 1920   | 1080           | 30P, 24P                    | 60Hz                   | 70.6kHz                     | 162MHZ                   | 81MHZ                                    | na                           |
| 1280   | 720            | 60P, 30P, 24P               | 60Hz                   | 47.1kHz                     | 60MHZ                    | 30MHZ                                    | ML6426-5<br>ML6426-4         |
| 704    | 480*           | 60I                         | 60Hz                   | 15.7kHz                     | 13.5MHZ                  | 6.75MHZ                                  | ML6426-1                     |
| 704    | 480            | 60P, 30P, 24P               | 60Hz                   | 31kHz                       | 27MHZ                    | 13.5MHZ                                  | ML6426-2                     |
| 640    | 480*           | 60I                         | 60Hz                   | 15.7kHz                     | 24.5MHZ                  | 12MHZ                                    | ML6426-2                     |
| 640    | 480            | 60P, 30P, 24P               | 60Hz                   | 31kHz                       | 12.27MHZ                 | 6MHZ                                     | ML6426-1                     |

P=progressive scan, I=interlaced scan

\*NTSC display rates, can be fed directly into NTSC encoder (set top box)

\*\* 60Hz also includes 59.94Hz

\*\*\* custom frequencies ranging +- 3 to 6MHz can be special cut to order

Table 2. Filter Selection Verses Resolution in HDTV or SDTV

# Application Brief 12

| PIXELS LINES | VERTICAL | REFRESH | REFRESH RATE (prog except noted) | HORIZONTAL RATE | SAMPLE CLOCK | RECON-STRUCION FILTER CUTOFF | MICRO LINEAR PART NUMBER *** |
|--------------|----------|---------|----------------------------------|-----------------|--------------|------------------------------|------------------------------|
| 640          | 480      | VGA     | 60Hz                             | 31.5kHz         | 25.175MHZ    | 12.5MHz                      | ML6426-2                     |
|              |          |         | 72Hz                             | 37.9MHZ         | 31.5MHZ      | 15.5MHz                      | ML6426-3                     |
|              |          |         | 75Hz                             | 37.5kHz         | 31.5MHZ      | 15.5MHz                      | ML6426-3                     |
| 800          | 600      | SVGA    | 56Hz                             | 35.1kHz         | 36MHZ        | 18MHZ                        | ML6426-3                     |
|              |          |         | 60Hz                             | 37.9kHz         | 40MHZ        | 20MHZ                        | ML6426-3                     |
|              |          |         | 72Hz                             | 48.1kHz         | 50MHZ        | 25MHZ                        | ML6426-3                     |
|              |          |         | 75Hz                             | 46.9kHz         | 49.5MHZ      | 25MHZ bn                     | ML6426-3                     |
| 1024         | 768      | XGA     | 43Hz interlace                   | 35.5kHz         | 44.9MHZ      | 23MHZ                        | ML6426-3                     |
|              |          |         | 60Hz                             | 37.9MHZ         | 65MHZ        | 33MHZ                        | ML6426-4<br>ML6426-5         |
|              |          |         | 70Hz                             | 56.5MHZ         | 75MHZ        | 37.5MHZ                      | ML6426-5                     |
|              |          |         | 75Hz                             | 60MHZ           | 78.75MHZ     | 39.4MHZ                      | ML6426-6                     |
| 1280         | 1024     | sxga    | 75Hz                             | 80kHz           | 135MHZ       | 68MHZ                        | na                           |
|              |          |         | 60Hz                             |                 | 133MHZ       | 57MHZ                        | na                           |
| 1600         | 1200     | uxga    | 60Hz                             |                 | 166MHZ       | 83MHZ                        | na                           |

**Table 3. VGA Resolution verses Nyquist Reconstruction Filter**

| ML6426-X | 3DB CUTOFF (CORNER FREQUENCY) |
|----------|-------------------------------|
| ML6426-1 | 6.7MHz                        |
| ML6426-2 | 12MHz                         |
| ML6426-3 | 24MHz                         |
| ML6426-4 | 30MHz                         |
| ML6426-5 | 36MHz                         |
| ML6426-6 | 48MHz                         |
| na       | 77MHz                         |

**Table 4. Filter Cut Off Frequencies**

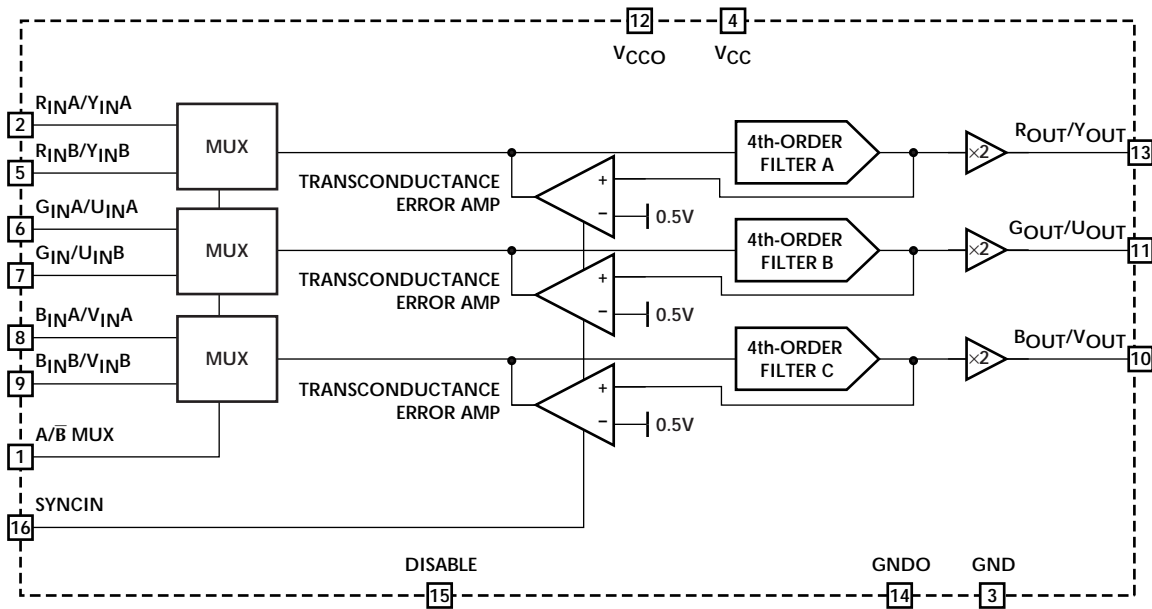

Figure 1. ML6426 Block Diagram

## **DISCLAIMER**

FAIRCHILD SEMICONDUCTOR RESERVES THE RIGHT TO MAKE CHANGES WITHOUT FURTHER NOTICE TO ANY PRODUCTS HEREIN TO IMPROVE RELIABILITY, FUNCTION OR DESIGN. FAIRCHILD DOES NOT ASSUME ANY LIABILITY ARISING OUT OF THE APPLICATION OR USE OF ANY PRODUCT OR CIRCUIT DESCRIBED HEREIN; NEITHER DOES IT CONVEY ANY LICENSE UNDER ITS PATENT RIGHTS, NOR THE RIGHTS OF OTHERS.

## **LIFE SUPPORT POLICY**

FAIRCHILD'S PRODUCTS ARE NOT AUTHORIZED FOR USE AS CRITICAL COMPONENTS IN LIFE SUPPORT DEVICES OR SYSTEMS WITHOUT THE EXPRESS WRITTEN APPROVAL OF THE PRESIDENT OF FAIRCHILD SEMICONDUCTOR CORPORATION. As used herein:

1. Life support devices or systems are devices or systems which, (a) are intended for surgical implant into the body, or (b) support or sustain life, and (c) whose failure to perform when properly used in accordance with instructions for use provided in the labeling, can be reasonably expected to result in a significant injury of the user.
2. A critical component in any component of a life support device or system whose failure to perform can be reasonably expected to cause the failure of the life support device or system, or to affect its safety or effectiveness.