

by John Sampson

## Low Cost Non-Dimming 220V Ballast Design

### GENERAL DESCRIPTION

This application note describes a high performance low cost ballast design using the ML4831 electronic ballast controller IC. The design can be evaluated by assembling the parts listed in this document.

Operating over the range of 198 to 242V<sub>RMS</sub> this power factor corrected 60W electronic ballast is designed to power two series-connected F32T8 fluorescent lamps and displays all the features of Micro Linear's ML4831 ballast controller IC. The mode of operation used for preheating and striking of the lamps is the widely accepted variable frequency, non-overlapping inverter topology.

Figure 1 displays the block diagram of this 220 volt ballast design.

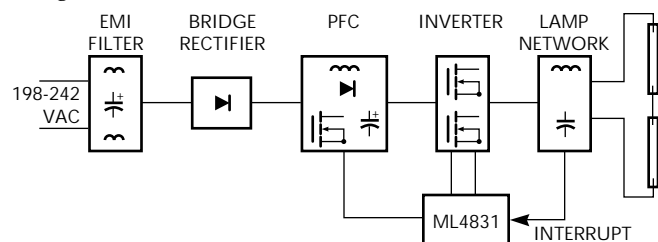

Figure 1

Applying AC line voltage to the ballast will supply start-up power to the ML4831 enabling gate drive for the PFC boost MOSFET Q1 and the inverter FETs Q2 & Q3. PFC action generates a well regulated 380VDC supply for the lamp inverter circuit and a low DC supply voltage for the ML4831. The inverter stage consists of 2 totem pole configured N-channel power MOSFETs with their common node supplying the lamp network. The pair of MOSFETs are driven out of phase by the ML4831 at a 50% duty cycle.

The lamp network is single low pass LC section which, when controlled from the ML4831, provides:

- Adjustable Lamp Power
- Required Lamp Starting Voltage
- Controllable Preheating Filament and Lamp Voltages
- Near Unity Power Factor
- High Input Impedance During Starting or Lamp-Out-of-Socket Conditions
- Less than 5% Change in Lamp Current Over Line Voltage Operating Range

The series connected lamps are across the output of the network.

### LAMP NETWORK DESIGN

The ML4831 allows the designer to select the filament preheating frequency and the lamp starting/minimum operating frequency.

The operation of the lamp network can be described by these equations:

$$\text{Open Circuit (lamp starting)} \quad e_o = \frac{e_{in} x_c}{x_l + x_c} \quad (1)$$

$$\text{During Lamp Operation} \quad Q = \sqrt{\frac{r_l}{r_{in}} - 1} \quad (2)$$

Where:

- $e_{IN}$  = Equivalent RMS Network Input Voltage
- $e_o$  = Open Circuit Network Output Voltage
- $V_B$  = PFC Output Voltage
- $x_c$  = Reactance of Shunt Capacitor
- $x_l$  = Reactance of Series Inductor
- $Q$  = Transformation Q of network
- $r_l$  = Equivalent Lamp Resistance at  $P_o$
- $r_{IN}$  = Transformed Value of  $r_l$  Needed to Produce  $P_o$
- $P_o$  = Desired Lamp Power (Arc and Filament)

High frequency measurements using reference lamps and ballast, as described in ANSI Standards C82.3-1983 and C78.375-1991, must be performed to determine lamp current and voltage at the desired ballast factor. These values are used to determine  $P_o$  and  $r_l$ .

Since the PFC uses a boost type converter:

$$\begin{aligned} V_B &> \sqrt{2} \times V_{RMS} \text{ line (max);} \\ V_B &> (1.414) (1.1) (220), \text{ and thus} \\ V_B &> 342\text{VDC (380VDC is used).} \end{aligned}$$

The RMS amplitude of a square wave's fundamental is  $\sqrt{2}/\pi$  times its peak-to-peak value.

So,

$$e_{IN} = 0.45V_B = 171V_{RMS}$$

And by assuming negligible losses in the reactances:

$$\begin{aligned} r_{IN} &= \frac{e_{IN}^2}{P_o} \\ &= \frac{171^2}{55} = 533\Omega \end{aligned} \quad (3)$$

# Application Note 52

From high frequency reference ballast measurements, F32T8 lamps operating at an 0.88 ballast factor,

$$\text{Lamp Current} = 0.18A_{\text{RMS}}$$

$$\text{Lamp Voltage} = 136V_{\text{RMS}}$$

$$\text{Lamp Arc Power} = 49 \text{ watts (total)}$$

$$P_{\text{O}} \text{ (total)} = 55 \text{ watts (allocating 6 watts to filaments)}$$

$$r_{\text{L}} = 1500\Omega \text{ (total),}$$

and from equation 2,  $Q = 1.35$

Values for  $x_{\text{C}}$  and  $x_{\text{L}}$  can be found from:

$$Q = \frac{x_{\text{L}}}{f_{\text{IN}}} = \frac{r_{\text{L}}}{x_{\text{C}}} \quad (4)$$

Thus  $x_{\text{C}} = -1113\Omega$  and  $x_{\text{L}} = 718\Omega$ , and, from equation 1,  $e_{\text{O}} = 481 V_{\text{RMS}}$ .

## CHOOSING THE STARTING/OPERATING FREQUENCY

The operating frequency,  $f_{\text{MIN}}$ , was found by selecting a frequency that makes the shunt network capacitor a standard value using the values for  $x_{\text{C}}$  and  $x_{\text{L}}$  found in equation 4. A 4.7nF capacitor makes  $f_{\text{MIN}}$  30.5kHz and the inductor 3.75mH.

For lamp rectification protection, line isolation, and lamp out detection 33nF capacitors, C9 and C22, (see figure 5) were added in series with the inductor (T3 primary) on both the high and low sides of the line. The size of the inductor was increased to 5.4mH to compensate for the added capacitance.

## Choosing the Preheating Frequency

The lamp starting scenario is the ballast feature that has the greatest impact on lamp life. The ML4831, when used with a properly designed lamp network, allows a designer to select:

- The preheating frequency which sets voltage across the lamps and cathodes during the preheating interval
- The length of the filament preheating time interval

ANSI C82.11-1993 sets the minimum preheating time at 0.5 seconds. A time of 0.7 seconds was used in this design with  $265V_{\text{RMS}}$  across the lamps. 260 volts was selected to ensure low glow current.

First select the voltage across the lamps during the preheating interval. Then use equation 1 to find the preheating frequency of 44kHz. This should be above  $f_{\text{MIN}}$  to make the network inductive.

## Selecting Oscillator Components

Inverter frequencies  $f_{\text{MIN}}$  and  $f_{\text{PREHT}}$ , that were chosen to be 30.5kHz and 44kHz, respectively, are 1/2 of the corresponding oscillator frequency. Refer to the ML4831 Data Sheet for the equations and device parameters to calculate  $r_{\text{T}}$  and  $r_{\text{S}}$ . To get a discharge time near  $1\mu\text{s}$ , the value for  $c_{\text{T}}$  was chosen at 2.2nF.

## NETWORK INDUCTOR DESIGN

Since maximum stress on the inductor occurs during preheating, these conditions were used for its design.

At  $f_{\text{PREHT}}$  (44kHz):

$$x_{\text{L}} = 1492\Omega$$

$$x_{\text{C}} = -772\Omega$$

$$e_{\text{O}} = 265V_{\text{RMS}}$$

$$V_{\text{IND}} = \left(\frac{265}{772}\right)1492 = 513V_{\text{RMS}} \quad (5)$$

The E 25/7 (EF 25) core was selected because:

- Low Cost and Availability
- High Ae (core) X Aw (bobbin)
- Efficient size for 90VA at 30kHz and 2000 gauss

For 2 turn filament windings at  $4.5V_{\text{RMS}}$  during preheating:

$$\frac{v}{t} = \frac{4.5}{2} = 2.25 \quad (6)$$

So the inductor turns are:

$$N = \frac{513}{2.25} = 228 \text{ turns} \quad (7)$$

Operating at an induction level of 2194 gauss during the lamp preheating interval.

Voltage across the inductor during normal lamp operation:

$$\begin{aligned} V_{\text{IND}} &= (x_{\text{L}}) \sqrt{\left(\frac{v_{\text{L}}}{r_{\text{L}}}\right)^2 + \left(\frac{v_{\text{L}}}{x_{\text{C}}}\right)^2} \\ &= 1034 \sqrt{\left(\frac{272}{1500}\right)^2 + \left(\frac{272}{-1113}\right)^2} = 315V_{\text{RMS}} \end{aligned} \quad (8)$$

Where:

$$x_{\text{L}} = \text{Reactance of T3 (primary) at } f_{\text{MIN}}$$

$$v_{\text{L}} = \text{Voltage Across Lamps}$$

$$r_{\text{L}} = \text{Total Equivalent Resistance of Lamps}$$

$$x_{\text{C}} = \text{Reactance of C8 at } f_{\text{MIN}}$$

The filament voltages during normal lamp operation:

$$V_{\text{FIL}} = \frac{(315)(2)}{228} = 2.76V_{\text{RMS}} \quad (9)$$

## LAMP OPERATION

In equation 4 the entire load resistance is across the shunt capacitor. By taking the filament load,  $r_F$ , from a winding on the inductor, a resistance larger than the  $r_{\text{IN}}$  calculated in equation 3 is transformed which reduces the power available for the lamps. In this design, the filament power is small compared to the lamp arc power, so the mismatch is small. This effect can be mitigated by operating at a frequency slightly higher than  $f_{\text{MIN}}$ .

Network  $Z_{\text{IN}}$  is found from the equation:

$$Z_{\text{IN}} = (r_{\text{LS}} + r_{\text{FS}}) + j(x_{\text{LS}} + x_{\text{CS}}) \quad (10)$$

Where:

- $r_{\text{LS}}$  = Transformed Series Lamp Resistance
- $r_{\text{FS}}$  = Transformed Series Filament Resistance
- $x_{\text{LS}}$  = Transformed Series T3 (primary) reactance
- $x_{\text{CN}}$  = Total Series Reactance of C9 and C22
- $x_{\text{CS}}$  = Transformed Series Capacitive Reactance of C8

Expanded:

$$Z_{\text{IN}} = \left( \frac{r_{\text{L}}}{1+Q^2} + \frac{r_{\text{F}} \times n^2}{1+Q_{\text{F}}^2} \right) + j \left( \frac{x_{\text{L}} \times Q_{\text{F}}^2}{1+Q_{\text{F}}^2} + x_{\text{CN}} + \frac{x_{\text{C}} \times Q^2}{1+Q^2} \right) \quad (11)$$

$$Q_{\text{F}} = \frac{r_{\text{F}} \times n^2}{x_{\text{L}}} \quad (12)$$

$$\begin{aligned} Q &= \frac{r_{\text{L}}}{x_{\text{C}}} \quad \text{and} \quad n = \frac{\text{inductor turns}}{\text{filament turns}} \\ &= \left( \frac{1500}{1+1.35^2} + \frac{(2.5)(114^2)}{1+31^2} \right) + \\ & j \left( \frac{(1034)(31^2)}{1+31^2} \right) - 316 + \frac{(-1113)(1.35^2)}{1+1.35^2} \quad (13) \\ &= 531 + 34 + j(1033 - 316 - 719) = 565 - j2 \end{aligned}$$

As you can see from the results, the transformed filament resistance slightly reduced the power to the lamps.

$$P_{\text{O(new)}} = 51.8 \text{ watts} \quad (14)$$

## LAMP OUT PROTECTION

As with all resonant topology circuits, the highest component stress occurs at open load. This can be controlled by operating only close enough to resonance to produce adequate starting voltage. When we chose the starting voltage and derived  $f_{\text{MIN}}$ , the open circuit input impedance of the network was defined as:

$$\begin{aligned} Z_{\text{IN}} &= r_{\text{FS}} + j(x_{\text{LS}} + x_{\text{CN}} + x_{\text{C}}) \\ &= 34 + j(1033 - 316 - 1113) = -396\Omega \quad (15) \end{aligned}$$

Where:

- $r_{\text{FS}}$  = Transformed Series Filament Resistance
- $x_{\text{LN}}$  = Transformed Series Inductive Reactance
- $x_{\text{CN}}$  = Reactance of Series Capacitors C9 and C22
- $x_{\text{C}}$  = Reactance of Shunt Capacitor, C8

When operating at the resonant frequency of 40.4kHz  $Z_{\text{IN}}$  is  $34\Omega$  but by operating at  $f_{\text{MIN}}$ ,  $Z_{\text{IN}}$  is  $396\Omega$  capacitive. Although  $Z_{\text{IN}}$  is relatively high, switching losses would waste power and require additional heat sinking if not for the ML4831's duty cycle interruption feature.

The ML4831 uses duty cycle interruption of the inverter gate drive with the off time set by C13 and R15 (See figure 5). Refer to the ML4831 Data Sheet for information on value selection. Unloaded conditions are detected by sampling a voltage across C22, with a small capacitor. This voltage is then DC restored, rectified, filtered and applied to pin 9 of the ML4831. If a lamp is out of its socket, or does not ignite for any reason, the voltage across C22 will be more than 50% higher than when both lamps are operating and is high enough to activate the interrupt.

## Ballast Performance

A typical ballast of this design will have the following performance characteristics:

- Efficiency: 92%
- Total Harmonic Distortion: 5%
- Power Factor: 0.99
- Current Crest Factor: 1.3

## TYPICAL WAVEFORMS

Figures 2 through 4 display typical oscilloscope waveforms taken at various points on the prototype. A brief description precedes each figure. Test conditions and oscilloscope settings are given below each photo. The waveforms were taken with the ballast powering two series connected F32T8 lamps.

### PFC BOOST VOLTAGE (FIG. 2)

The DC bus for the inverter stage is derived from the rectified AC line. Note the 120Hz (2x line frequency) ripple voltage superimposed on the DC voltage. This is the result of the power factor correction of the AC line voltage.

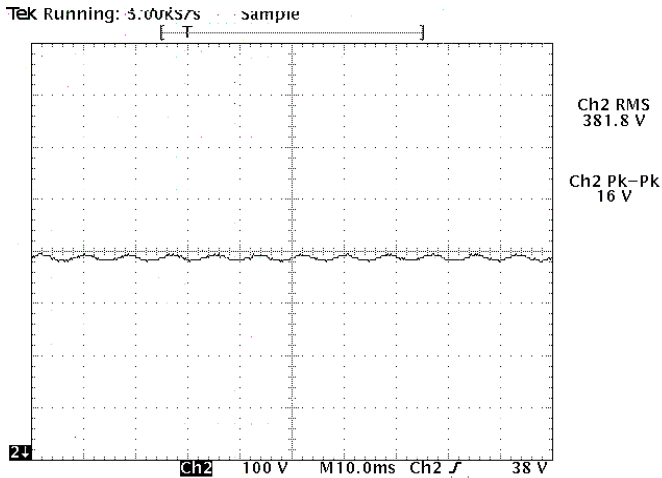

Figure 2. PFC Boost Voltage

### INVERTER VOLTAGE/CURRENT (FIG. 3)

The boosted DC bus voltage is chopped by Q2 & Q3, which causes a square wave to appear at the input to the lamp network (Q2/Q3/T3 node). The lamp network input current is sinusoidal due to the network Q. The current and voltage waveforms are in phase which indicates resonant operation and results in the minimum VA being supplied by the inverter to produce the required lamp watts.

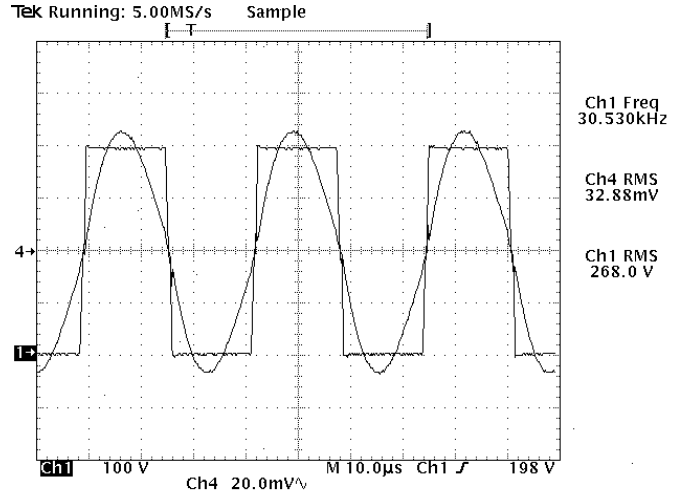

Figure 3. Inverter Output Voltage/Current

### LAMP CURRENT/VOLTAGE (FIG. 4)

A comparison of the lamp current and voltage is shown in Fig. 4. The small phase difference is typical when lamps are operated at high frequencies and is an indication of the increased lamp efficacy as compared to 60HZ operation. The lamp current crest factor (CCF) is approx. 1.3, well below the 1.7 limit.

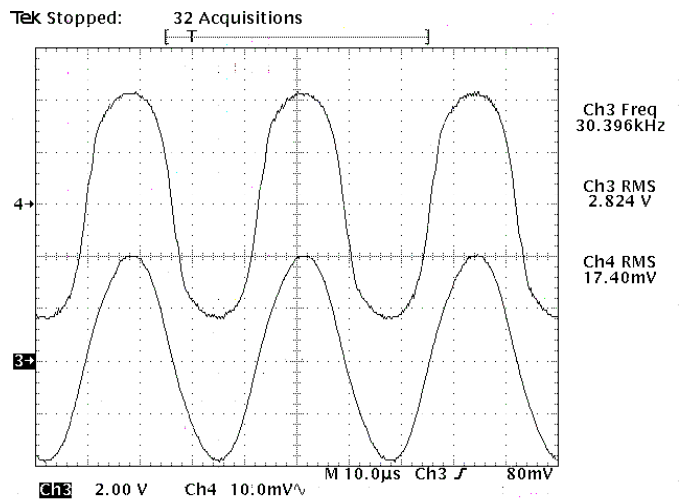

Figure 4. Lamp Current/Voltage

## 220 VOLT ML4831 PARTS LIST

Item	Qty	Description	Vendor/Parts	Designation
Resistors				
1	1	1.0 $\Omega$ , 1/2 W, 5% metal film	NTE/HW1DO	R1
2	1	1.0k $\Omega$ , 1/4 W, 5% carbon film	Yageo/1.0K-Q	R2, R16
3	1	9.1k $\Omega$ , 1/4 W, 5% carbon film	Yageo/9.1K-Q	R3
4	1	12k $\Omega$ , 1/4 W, 5% carbon film	Yageo/12K-Q	R4
5	1	15.4k $\Omega$ , 1/4 W, 1% metal film	Dale/SMA4-15.4K-1	R5
6	2	332k $\Omega$ , 1/4 W, 1% metal film	Yageo/SMA4-332K-1	R6, 11
7	1	68k $\Omega$ , 1 W, 5% carbon film	Yageo/68KW-1ND	R7
8	3	22 $\Omega$ , 1/4 W, 5% carbon film	Yageo/22-Q	R8, R9, R18
9	1	11.5k $\Omega$ , 1/4 W, 1% metal film	Dale/SMA4-11.5K-1	R10
10	2	442k $\Omega$ , 1/4 W, 1% metal film	Dale/442KXTR-ND	R12, R23
11	1	5.90k $\Omega$ , 1/4 W, 1% metal film	Dale/SMA4-5.90K-1	R13
12	1	110k $\Omega$ , 1/4 W, 5% carbon film	Yageo/110K-Q	R14
13	1	324k $\Omega$ , 1/4 W, 1% metal film	Dale/SMA4-324K-1	R15
14	2	51 $\Omega$ , 1/4 W, 5% carbon film	Yageo/51-Q	R17, R19
15	1	5k $\Omega$ potentiometer	Bourns/3386P-502-ND	R21
Capacitors				
16	2	2.2nF, 250 VAC, 10% "Y" Cap.	WIMA/MP3-Y	C1, C2
17	1	0.15 $\mu$ F, 300V, 10% "X" Cap.	WIMA/MP3-Y	C3
18	1	0.1 $\mu$ F, 50V, 20% ceramic	AVX/SR215E105MAA	C4, C5
19	1	2.2nF, 50V, 2.5% NPO ceramic	AVX/RPE121C0G222	C6
20	1	330pF, 50V, 10% ceramic	AVX/SR151A331JAA	C7
21	1	4700pF, 630V, 5% polypropyl.	WIMA/MKP10	C8
22	2	33nF, 250V, 5% polypropyl.	WIMA/MKP10	C9, C22
23	1	47 $\mu$ F, 450V, 20% electrolytic	Panasonic/ECO-S2WP470	C10A, C10B
	1	47nF, 50V, 20% ceramic	AVX/SR211C472KAA	C11
	1	0.33 $\mu$ F, 50V, 20% ceramic	AVX/SR251E334MAA	C12, C19
24	1	10 $\mu$ F, 16V, 20% electrolytic	Panasonic/ECE-A1C100	C13
25	2	0.22 $\mu$ F, 50V, 10% ceramic	AVX/SR305C224KAA	C14, C15
26	1	100pF, 100V, 5% ceramic	AVX/SR211A101JAA	C16
27	1	1 $\mu$ F, 50V, +80/-20% ceramic	AVX/SR305E105ZAA	C17
	1	220 $\mu$ F, 16V, 20%, electrolytic	Panasonic/ECE-A16U221	C18
28	1	330 $\mu$ F, 25V, 20% electrolytic	Panasonic/ECE-A1EU331	C20
29	1	0.001 $\mu$ F, 1000V, 10% ceramic capacitor	AVX/SR251E334MAA	C21
30	1	220 $\mu$ F, 16V, 20% electrolytic	Panasonic/ECE-A1CU221	C24
*31	1	4.7nF, 50V, 10% ceramic	AVX/SR211C472KAA	C25
Diodes				
32	5	1A, 600V (1N4007 or 1N5061)	Motorola/1N4007TR	D1-D4, D12
33	2	1A, 50V (or greater)	Motorola/1N4001TR	D5, D6
34	1	1A, 600V ultrafast	GI/BYV26C	D7
35	3	0.1A, 75V signal	Motorola/1N4148TR	D8, D11, D13

# Application Note 52

## 220 VOLT ML4831 PARTS LIST (Continued)

Item	Qty	Description	Vendor/Parts	Designation
Diodes (Continued)				
36	1	1A, 50V fast	GI/1N4933	D9
37	1	15V, 1W 5% zener	ITT/1N4744A	D10
ICs				
38	1	ML4831 Electronic Ballast Controller	Micro Linear	IC2
Transistors				
39	3	2.5 A, 500V power MOSFET	IR/IRF820	Q1 - 3
Inductors				
40	2	EMI/RFI Common Mode Inductor, 16.8mH (min)	Coilcraft/E3495A	L1
Fuses				
41	1	1A, 5 × 20 mm., miniature	Littlefuse/F945-ND	F1
42		PC mount clips 5 × 20 mm.	Littlefuse/F058-ND	
Hardware				
43	3	Single TO-220 Heatsinks	Aavid Eng./PB1ST-69	
44	3	Mica Insulators	Keystone/4673K-ND	

Item	Qty	Description	Designation
Magnetics			
45	1	Boost Inductor, 5.0mH, Premier Magnetics P/N TSD-746	T1
46	1	Gate Drive Xfmr, Lpri = 16mH (min), Premier Magnetics P/N TSD-747	T2
		Not used	T3
		Assembly note: Install jumpers from pin 10 to pin 4 and from pin 5 to pin 6.	
47	1	Inductor, Lpri = 5.4 mH: Premier Magnetics P/N TSD-800 EF25 core set, Seimens P/N B66317-G-X127 10 pin vertical bobbin Seimens P/N B66208-J1110-T001 Wind as follows: 1st: 228T of 28 AWG QPN magnet wire; Start pin #6, end pin #7; 1 layer of mylar tape 2nd: 2T of 28 AWG QPN magnet wire; Start pin #2, end pin #1 3rd: 2T of 28 AWG QPN magnet wire; Start pin #4, end pin #3 4th: 2T of 28 AWG QPN magnet wire; Start pin #8, end pin #9 Note: Gap for 5.4 mH ±3% (Al = 76 ± 3%) pins 6 to 7	T4

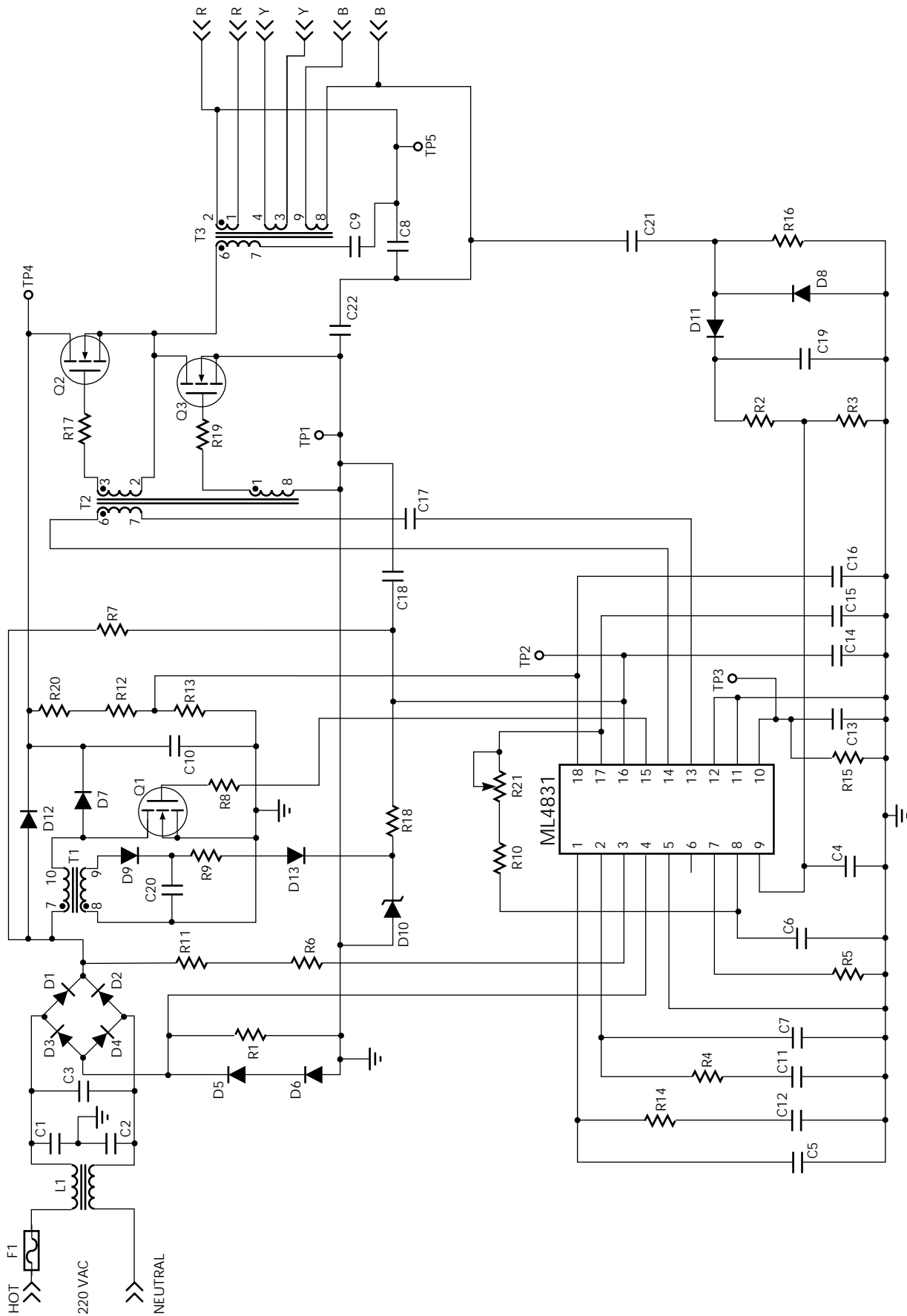

Figure 5. Schematic of the 220 Volt Low Cost Ballast

---

## **DISCLAIMER**

FAIRCHILD SEMICONDUCTOR RESERVES THE RIGHT TO MAKE CHANGES WITHOUT FURTHER NOTICE TO ANY PRODUCTS HEREIN TO IMPROVE RELIABILITY, FUNCTION OR DESIGN. FAIRCHILD DOES NOT ASSUME ANY LIABILITY ARISING OUT OF THE APPLICATION OR USE OF ANY PRODUCT OR CIRCUIT DESCRIBED HEREIN; NEITHER DOES IT CONVEY ANY LICENSE UNDER ITS PATENT RIGHTS, NOR THE RIGHTS OF OTHERS.

## **LIFE SUPPORT POLICY**

FAIRCHILD'S PRODUCTS ARE NOT AUTHORIZED FOR USE AS CRITICAL COMPONENTS IN LIFE SUPPORT DEVICES OR SYSTEMS WITHOUT THE EXPRESS WRITTEN APPROVAL OF THE PRESIDENT OF FAIRCHILD SEMICONDUCTOR CORPORATION. As used herein:

1. Life support devices or systems are devices or systems which, (a) are intended for surgical implant into the body, or (b) support or sustain life, and (c) whose failure to perform when properly used in accordance with instructions for use provided in the labeling, can be reasonably expected to result in a significant injury of the user.
2. A critical component in any component of a life support device or system whose failure to perform can be reasonably expected to cause the failure of the life support device or system, or to affect its safety or effectiveness.