

Application Note 43

Using the ML4425/ML4426 BLDC Motor Controllers

by John DeFiore

INTRODUCTION

The purpose of this document is to explain the theory and application of Micro Linear's ML4425 and ML4426 brushless DC motor controller IC's, with speed control. It shows typical applications, along with information about choosing the various components necessary for proper operation. It presents in depth control system information for those who wish to use it, but the user can pick component values without extensive analysis by using the formulas developed for each component.

GENERAL DESCRIPTION

The ML4425 and ML4426 provide sensorless commutation plus on chip PWM speed control for brushless DC motors. An integrating back EMF sensor, combined with an on-chip VCO and sequencer, form a phase locked commutation loop. The parts provide on chip braking and power failure detection. In 12V applications, they can drive external P and N channel FET's directly. Interface circuitry will allow driving of higher voltage motors. The ML4425 has an input for a variable motor current limit, while the ML4426 has forward and reverse capability.

THEORY OF OPERATION

During startup, the motor is initially at rest and has no back EMF to lock the commutator loop. In order to get sufficient back EMF to close the loop, it is necessary to start the motor "open loop", until the motor attains a speed of about 100 RPM. To accomplish this, the VCO ramps linearly, accelerating the motor to speed. Once at minimum speed the loop is closed and the motor accelerates to operating speed under closed loop commutation. The non-energized phase provides the feedback necessary to properly commutate the motor. The phase voltage is integrated over a 60 degree interval. (Figure 1 shows an idealized phase waveform with the motor back EMF superimposed as the dotted line.)

If the commutation is perfect, no net voltage change will occur on the output filter. If the commutation is early or late, the output filter will pump up or down to bring the next commutation closer to the ideal position. (For a detailed servo analysis of the commutation loop see the section on picking critical component values.) Finally an on chip PWM speed loop provides speed control.

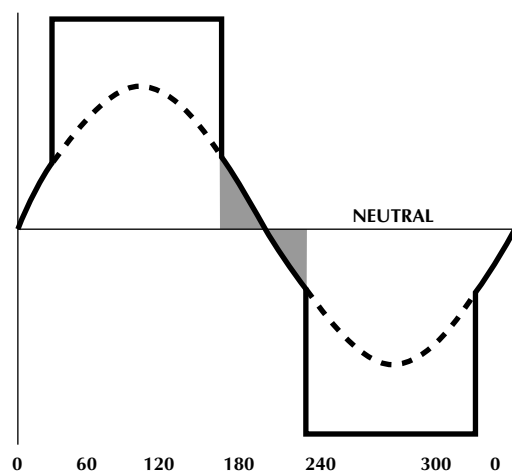

Figure 1. Motor Phase Waveform with Back-EMF Superimposed (Ideal Commutation)

Application Note 43

HOW TO OPERATE THE ML4425/ML4426

Figure 2 shows a typical application for the ML4425/ML4426. The parts are a flexible building block for motor driver systems. Because of the variations in the types of applications and motors, the first step in using the ML4425/ML4426 is to choose the major system components. Some of the system level choices are:

OUTPUT DRIVER SELECTION AND INTERFACING

Output driver selection depends mainly on the motor voltage and current. For 12V motors, the chip can drive external N and P channel FET's directly. For motors up to 80V, the approach shown in Figure 5 can be used to drive the P channel FET's. For very high currents or voltages above 80V, the best scheme is to use N channel FET's in the high side, and use a high side drive interface, such as those available from IXYS, International Rectifier, and others. (See Figure 6). IGBT's could be used in place of FET's in this case. Note that during the alignment phase, the high side drivers are turned on first, and held on for the required settling time. This means that the typical charge pump scheme for driving the high side FET's will not work. A floating supply can be developed to provide power to the high side drivers. Another possible approach is to pulse the BRAKE input prior to starting, to build up a charge on the bootstrap caps. The reset period must not last long enough to significantly discharge the bootstrap caps. Use of the BRAKE function for braking is not recommended for high power drives.

STARTUP IMPLEMENTATION

Startup schemes are critical with sensorless motor drivers. The reason a startup scheme is necessary is that the back EMF of the motor is used to determine the position of the rotor. If the motor is not rotating, or is rotating slowly, there is little or no back EMF to sense. The ML4425/ML4426 uses an open loop approach to start the motor turning, then closes a PLL to lock the commutation phase to the phase of the rotor. The ML4425/ML4426 have built in analog startup circuitry. The following sequence starts the motor:

1. The IC is held in reset, for a time proportional to the value of the capacitor on pin 17, C_{RST} . This applies full current to the windings by turning two of the upper and one of the lower drivers on. This will cause the rotor to move to a point which is 30 electrical degrees before the first commutation step. The IC must be held in this state until the rotor has settled. (See the section on choosing the reset capacitor for more information.)

CAUTION!!!

Systems built with the ML4425/ML4426 may contain voltage potentials capable of causing serious injury and components which, when failed, may shatter or explode. Please use extreme caution when operating these parts. The use of protective eye wear is strongly recommended. To safely observe in-circuit waveforms an isolation transformer should be inserted between the AC line and the circuit under test. Caution is required when testing the part with motors. Loose fitting clothing can catch in the rotor or motor load causing injury. Ties are especially dangerous. Do not attempt to hold or stop the rotor with your hand, as this can cause injury as well. Use a dynamometer for load testing.

2. Once the reset capacitor charges past the threshold, the ramp state begins. An internal current source charges the filter on pin 20. This causes the VCO frequency to increase, commutating the motor in an open loop manner. This rate should not exceed the rate at which the rotor can turn, or the commutation loop will not lock. The time that the part remains in the ramp state is determined by C_{EN} , on pin 19.
3. When the ramp period is over, the part closes the commutation loop and begins normal operation.

CURRENT LIMIT CONTROL

The ML4425/ML4426 make use of a constant off time pseudo PWM scheme to limit the maximum current in the motor. During motor operation, a comparator compares the voltage across the current sense resistor (times a gain of 5) with an internal 2.5V reference. An internal one shot fires when the sensed current appearing as a voltage on the I_{SENSE} pin exceeds 0.5V. This shuts off the low side drivers for the one shot's off time. C_{OS} determines the one shot's off time. By choosing the off time appropriately, (See the section on choosing C_{OS}). In the ML4425, the 2.5V reference may be changed by changing the voltage on the I_{LIMIT} pin, pin 12. In this case, the average current will be proportional to the voltage on the I_{LIMIT} pin.

SPEED CONTROL

Speed control is internal to the ML4425/ML4426. The speed control operates as follows: The voltage on the RC pin, pin 20, will be proportional to motor speed. This is compared to the V_{SPEED} input by a transconductance amplifier. The output of the transconductance amplifier (the error signal) is changed to a voltage by the network on the C_{PWM} pin. This error signal feeds a PWM comparator. A ramp waveform feeds the other end of the PWM comparator. The capacitor on the C_{OSC} pin sets the frequency of the ramp and therefore the PWM frequency. This PWM signal switches the low side FET's, causing the motor speed to remain constant. The speed control loop may be broken and an external speed control added by removing the network attached to pin 5 and driving it with a low impedance source. This will change the PWM duty cycle applied to the motor, allowing external control.

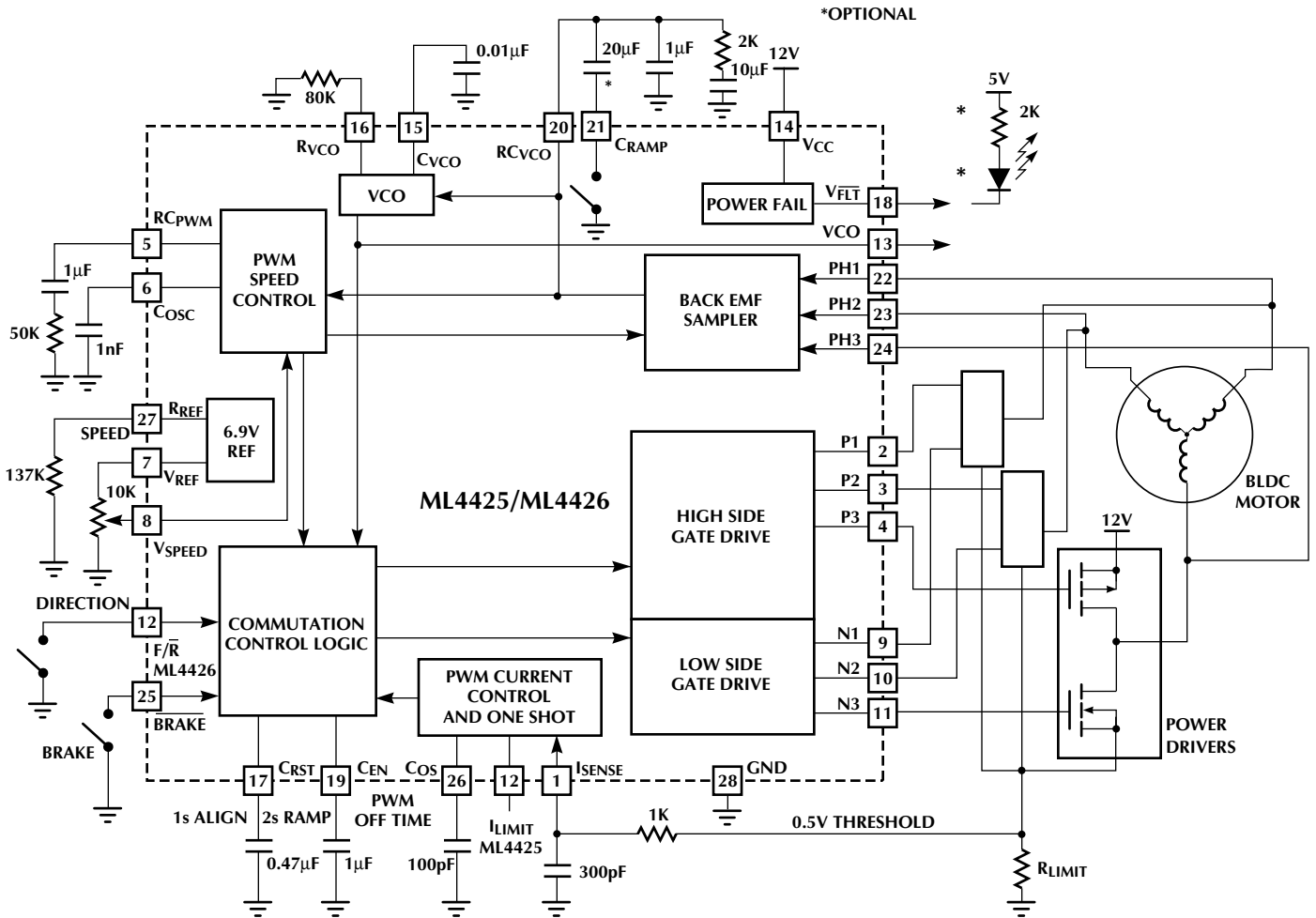

Figure 2. ML4425/ML4426 Typical Application

CRITICAL COMPONENT SELECTION

In order to properly select the critical components for the ML4425/ML4426 you should know the following things:

1. The motor operating voltage.
2. The maximum operating current for the motor.
3. The number of poles the motor has.
4. The back EMF constant of the motor.
5. The torque constant of the motor.
6. The desired speed of operation.
7. The moment of inertia of the motor and its load.
8. The coefficient of viscous friction.

If you do not know one or more of the above values, it is still possible to pick components for the ML4425/ML4426, but some experimentation may be necessary to determine the optimal values.

Operation of the parts require choosing the following components. The previous values are necessary to choose some of them.

1. R_{SENSE} , the motor current sense resistor.
2. The I_{SENSE} filter network.
3. C_{OS} , the one shot timing capacitor.
4. C_{VCO} , the VCO timing capacitor.
5. The reset capacitor, C_{RST} .
6. The enable capacitor, C_{EN} , and possibly C_{RAMP} .
7. The PWM oscillator timing capacitor C_{PWM} .
8. The speed loop filter network C_{PWM} and R_{PWM} .
9. The VCO filter components, C_1 , C_2 and R .

Application Note 43

The purposes of these components are explained in the following sections, and the following motor will be used as an example for choosing components:

Voltage	12V
Number of poles	12
Ko	0.269
Kt	$25 \times 10^{-5} \text{ N} \times \text{m/A}$
Desired RPM	5400
Viscous damping factor	0.4
Moment of Inertia	$72 \times 10^{-6} \text{ Kg} \times \text{m}^2$
Maximum current	2A

R_{SENSE}

The function of R_{SENSE} is to provide a voltage proportional to the motor current, for current limit purposes. The current limit one shot will trip when the voltage across the sense resistor reaches 0.5V. In order to pick a value for R_{SENSE}, it is necessary to know the maximum current delivered to the motor. This is a function of how much starting torque is required, the acceptable temperature rise in the windings, the rotational losses and the maximum permissible magnetic field. If the motor is sized correctly, the maximum current will be the current necessary to start the motor against its maximum load. This is given by the starting torque divided by the torque constant. Choosing R_{SENSE} to give a maximum current of I_{MAX} yields the following equation:

$$R_{\text{SENSE}} = \frac{0.5}{I_{\text{MAX}}}$$

I_{MAX} is the maximum motor current.

The power dissipation is obviously I_{MAX} squared times R_{SENSE}, so the resistor should be sized appropriately. For the example motor, R_{SENSE} should be 0.25Ω. The power dissipated is 1W, so choose a 2W resistor.

I_{SENSE} FILTER

The I_{SENSE} filter consists of an RC lowpass filter in series with the current sense signal. The purpose of this filter is to filter out noise spikes on the current, which may cause false triggering of the one shot circuit. It is important that this filter not slow down the current feedback loop, or destruction of the output stage may result. The recommended values for this circuit are R = 1KΩ and C = 300pF. This gives a time constant of 300ns, and will filter out spikes of shorter duration. These values should suffice for most applications. If excessive noise is present on the I_{SENSE} pin, the capacitor may be increased at the expense of speed of current loop response. The filter time constant should not exceed 600ns or it may have a significant impact on the response speed of the one shot current limit circuit.

C_{OS}

The one shot capacitor determines the off time after the current limit is activated, i.e. the voltage on the I_{SENSE} pin (pin 12) exceeded the voltage on the I_{LIMIT} pin (pin 27). This value should allow the winding current to decay during the off time by an amount equal to the increase in the current in the minimum on time. The minimum on time for the one-shot is approximately 1μs. In a system with low on resistance parts and high Q motor windings (The Q is the ratio of the winding's reactive impedance to the resistance.) It is necessary to have an off time given by the following equation:

$$T_{\text{OFF}} = 1.11 \times 10^{-6} \times V_{\text{MOTOR}}$$

V_{MOTOR} is the voltage applied to the motor windings.

The capacitance for a given off time may be read from the graph on P.5-113 of the datasheet, or for values larger than 30μs, the following formula may be used:

$$T_{\text{OFF}} = 947.4 \times C_{\text{OS}} + 5$$

T_{OFF} in microseconds, C_{OS} in microfarads.

Solving for C_{OS}:

$$C_{\text{OS}} = \frac{1.11 \times 10^{-6} \times V_{\text{MOTOR}} - 5 \times 10^{-6}}{947.4}$$

Now C_{OS} is in Farads.

This is the maximum value that C_{OS} should be. Higher average torque during the current limit cycle can be achieved by reducing this value experimentally, while monitoring the motor current carefully, to be sure that a runaway condition does not occur. This runaway condition occurs when the current gained during the on time exceeds the current lost during the off time, causing the motor current to increase until damage occurs. For most motors this will not occur, as it is usually a self limiting phenomenon. For the example motor, C_{OS} comes out to 8.8nF, so a 10nF capacitor would be a safe choice.

C_{VCO}

It is important to pick the VCO capacitor so that the nominal operating speed corresponds to about 3.75V at the RC pin (pin 20). In variable speed applications the voltage on pin 20 should also not exceed 7V. The VCO frequency is given by:

$$F_{\text{MAX}} = 0.05 \times N \times \text{RPM}$$

N is the number of poles.

The VCO gain is:

$$K_{\text{VCO MIN}} = \frac{2.42 \times 10^{-6}}{C_{\text{VCO}}}$$

So making a linear approximation, VCO frequency is given by:

$$F = K_{VCO} \times V_{RC}$$

Solving for V_{RC} which is the voltage at pin 20, we get:

$$V_{RC} = \frac{0.05 \times N \times RPM \times C_{VCO}}{2.42 \times 10^{-6}}$$

Finally, setting V_{RC} equal to 3.75V, solving for C_{VCO} and simplifying, gives:

$$C_{VCO} = \frac{1.815 \times 10^{-4}}{N \times RPM}$$

Now in a variable speed application, the previous equation can be used to ensure that the voltage at pin 20 does not exceed 7 volts at the maximum RPM. For the example motor, C_{VCO} would be 2.8nF, so 2.7nF would be a good choice. For very high speed (e.g. 100KRPM) or wide speed range motors, the dynamic range of the VCO may not suffice. The minimum VCO voltage is 0.5V, and the maximum is 7 volts. This gives a 14:1 speed control range, and may not allow very high speed motors to start. One technique for use with these motors is to use an analog switch with several VCO capacitors to switch the value of the VCO capacitance to lower values when certain speeds are reached. A comparator with hysteresis on pin 20 can sense the speed, and drive the analog switch. This has an effect similar to "shifting gears".

RESET CAPACITOR

The reset capacitor is connected to pin 17. The function of the reset capacitor is to provide a time delay, during which the part will lock the rotor to a known position. During this time period the part turns on two of the upper and one of the lower output drivers. This results in a fixed current in the windings, a stationary magnetic field, and a locked rotor. If the position is not at a torque null during the reset period, it will require some time to move to the locked position, and settle. This time period is dependent on the motor, the load, the friction and eddy current losses, and current limit setting. Solving the differential equation for the motor/load system can give an approximate starting value.

Assuming that the magnetic field causes a restoring torque proportional to the angular displacement, the rotor torque is:

$$\tau = -k \times \theta$$

k is the restoring torque slope in $N \times M/\text{radian}$, and θ is the displacement angle in radians.

Note that this is very similar to the settling of a damped spring mass system, and similar dynamics apply. The angular equivalent of $F = M \times A$ gives:

$$J \times \frac{d^2}{dt^2} \theta = -k \times \theta$$

J is the moment of inertia of the motor's rotor, plus load.

Adding a viscous friction and eddy current loss component:

$$J \times \frac{d^2}{dt^2} \theta + r \times \frac{d}{dt} \theta + k \times \theta = 0$$

r is the loss factor, which includes eddy current and viscous friction losses.

Solving the previous equation gives a resonant frequency of:

$$f = \frac{\sqrt{k}}{2 \times \pi \times J}$$

f is in Hz.

An N pole motor will have a worst case angle of π/N radians. A good approximation for settling time of a unit step to 5% is:

$$t_s = \frac{3}{\frac{r}{2 \times k} \times \sqrt{\frac{k}{J}}}$$

The $r/2k$ factor is known as the damping factor, and, can range from 0.1 in a motor with very little damping to 0.9 in a heavily damped motor. In an N pole motor, the torque nulls occur every $2 \times \pi/N$. In one half that angle, the motor goes from zero to full torque. Full torque is given by the motor torque constant, times the maximum current set by the I_{LIMIT} feature. Therefore, the restoring torque constant k is equal to:

$$k = \frac{N \times K_t \times I_{MAX}}{\pi}$$

I_{MAX} is the maximum current set by the I_{LIMIT} feature, in Amps. K_t is the motor torque constant in $N \times M$, and N is the number of motor poles.

The reset capacitor must charge to the threshold trip voltage during the settling time. A current source supplies $0.75\mu A$ into the capacitor, and the threshold is 1.5V. The time to charge is:

$$t_s = \frac{C \times 1.5V}{0.75 \times \mu A}$$

Solving for C:

$$C = \frac{t_s \times 0.75 \times \mu A}{1.5 \times V}$$

Application Note 43

For the example motor, the damping factor, $r/2k$ is given as 0.4. Therefore, t_s is approximately 1.5s. Choosing a conservative standard value, the reset capacitor should then be 0.56 μ F.

Start with the value of C calculated as shown. If the motor has not settled before the ramp up phase, then it will be necessary to increase the value of C until the motor is motionless when the ramp starts. If fast starting is essential, and the above value seems too large, a decrease in C will allow for faster starting. Note that part to part and supply tolerances require some safety margin in the selection of C . If the motor constants and load inertia are not known, or if enough nonlinear elements are present in the load, (e.g. friction), an empirical method may be used to determine C . Start with a 1 μ f capacitor. If the motor appears to have settled well before ramp up, half the capacitance value. If the motor has not settled by ramp up, double the value. When a change from not settled to settled, or vice versa is observed, home in on the optimum value by successively reducing the change in capacitance by 1/2, then increasing or decreasing the value as appropriate. This "binary search" method will allow quick convergence to the proper value.

ENABLE CAPACITOR

This capacitor provides a time delay after the reset period for the motor to ramp up to speed. The following equation gives an approximate starting value for this capacitor. If starting is not reliable, this capacitor may be increased until it is.

$$C = 1.27 \times 10^{-12} \frac{J}{(C_{VCO} \times (N \times (Kt \times I_{MAX})))}$$

Where J is the total inertia in $Kg \times m^2$. Kt is the torque constant in $N \times m/Amp$. C_{VCO} is the VCO capacitor in farads. N is the number of poles. I_{MAX} is the maximum current I_{LIMIT} .

Where C is C_{EN} connected to pin 19. For the example motor, $C_{EN} = 3.4\mu$ F.

VCO FILTER (RC PIN)

The VCO filter consists of a capacitor to ground, in parallel with a series resistor and capacitor to ground. (See Figure 4). The pin that drives this network is a transconductance stage, so that the voltage out to current in transfer function of this block is simply the impedance of the block. The purpose of this network is to filter the VCO frequency out of the position/commutation loop, and to provide phase compensation for the loop so that it is stable. The impedance of the network is:

$$\frac{R \times C2 \times s + 1}{s \times (C2 + R \times C1 \times s \times C2 + C1)}$$

In order to properly determine the values for this filter, it is necessary to do a servo analysis on the entire commutation loop. If the reader does not have an extensive background in servo systems, the formulas in boxes at the end of this section along with Table 1 can be successfully used to pick values for these components. It is necessary to know the back-EMF constant, Ke , of the motor to pick these values correctly. Since the commutation loop must have acceptable phase margin both at startup and at the maximum operating frequency, the compensation's phase lead should be located at the geometric mean between these two frequencies. For those who need detailed analysis the following information is given: The commutation loop is a phase locked loop, which locks to the rotor's position. Note that this inner loop does not attempt to modify the position of the rotor, but modifies the commutation times to match whatever position the rotor has. The speed loop changes the rotor velocity, and the commutation loop locks to the rotor's position to commutate the phases at the correct times. A servo analysis should start with a block diagram of the system dynamics (See Figure 3): The phase detector consists of the motor, the back EMF sampler/integrator, and the gm amplifier. The loop filter's transfer function follows the phase detector, and the VCO's gain is in the section on choosing C_{VCO} . Note that as in any PLL, the VCO is an integrator in that it accepts a voltage and outputs a frequency. Phase is defined as the integral of frequency, so this necessitates an s in the denominator of the VCO transfer function. Writing the expression for the open loop gain of the entire loop:

$$A_{OL} = Ke \times \frac{Kv}{2 \times \pi} \times \omega \times \text{Atten} \times gm \times \frac{R \times C2 \times s + 1}{s^2 (C2 + R \times C1 \times s \times C2 + C1)}$$

Where A_{ol} is the open loop gain, K_e is the back EMF constant of the motor in volts/radian/sec., K_v is the VCO gain in radian/sec/volt (NOT Hz/volt). ω is the rotor speed in radians/second (NOT RPM). $Atten$ is the resistive divider ratio used to divide down the back EMF from high voltage motors, (Nominally 0.5 if no external resistors.), and gm is the transconductance of the phase detector amplifier. (See the section on back EMF attenuation resistors for more details on $Atten$.)

Simplifying the above equation by making the following substitutions:

$$K_o = K_e \times \frac{K_v}{2 \times \pi} \times \omega \times Atten \times gm$$

$$\omega_z = \frac{1}{R \times C_2}$$

$$\omega_p = \frac{C_2 + C_1}{R(C_1 \times C_2)}$$

Yields:

$$A_{OL} = K_o \times \frac{s + \omega_z}{s^2 \times C_1(s + \omega_p)}$$

Note that the s^2 in the denominator gives rise to two poles at the origin, and 180 degrees of phase shift. In order for this system to be stable, the zero formed by the numerator

must give a positive phase shift when the magnitude crosses unity. This leads to the conclusion that the pole must occur after the magnitude crosses the unity gain frequency. The pole's frequency must be low enough to filter the VCO frequency out of the loop, and high enough to allow the zero to boost the phase margin of the loop are acceptable over all operating conditions. Writing the pole frequency as a multiple of the zero frequency gives:

$$\omega_p = M \times \omega_z$$

Then the maximum phase lead occurs at the geometric mean:

$$\omega_{MAXLEAD} = \sqrt{M} \times \omega_z$$

In PLL design it is common to approximate a third order loop by a second order model. This is valid because the filter pole occurs well after the open loop response has reached unity gain. If we approximate the system as a second order PLL, a damping factor of 0.7 will give very little overshoot and good transient response to disturbances. For a second order system, the settling time to $d\%$ is given by:

$$t_s = \frac{-\ln\left(\frac{d}{100}\right)}{\zeta \times \omega_n}$$

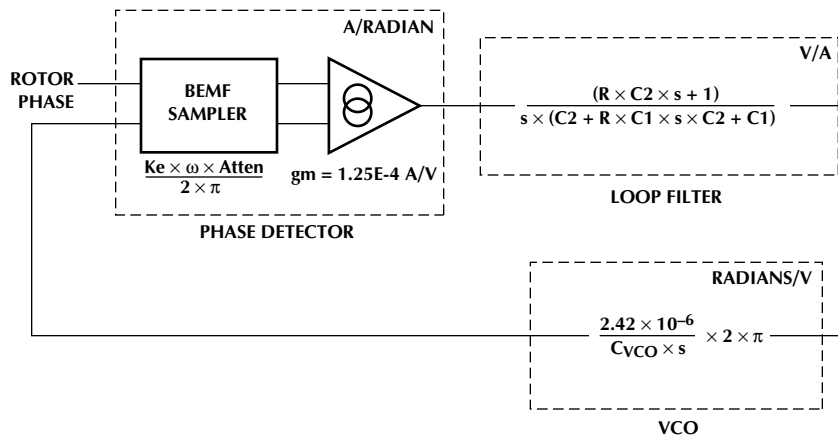

Figure 3.

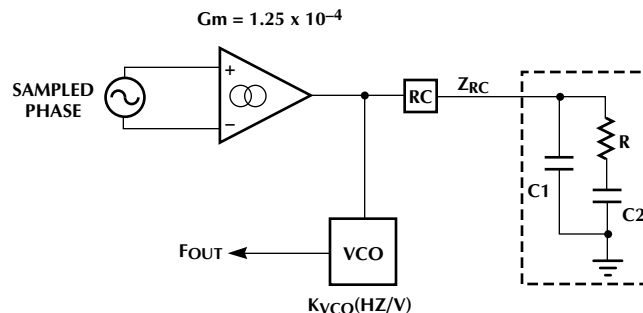

Figure 4. Back EMF Phase Lock Loop Components

Application Note 43

Where ζ is the damping factor, and ω_n is the natural frequency. If the PLL must settle within N_s cycles, then the time to settle is:

$$T_{ACQ} = \frac{N_s}{F_{VCO}}$$

N_s should be as small a number as possible while still allowing the loop filter to filter out the frequency components of the VCO. Asking for a settling time of one or two cycles would mean that the filter must respond on the order of the VCO frequency, and would not allow adequate filtering. Too long a settling time could cause improper commutation and loss of lock for abrupt changes in rotor position. A good choice for N_s would be 20 cycles. Using the second order relation:

$$\omega_o = 2 \times \zeta \times \omega_n$$

where ω_o is the bandwidth and ω_n is the natural or resonant frequency, and combining the above yields:

$$\omega_o = -2 \times \ln\left(\frac{1}{100}d\right) \times \frac{F_{VCO}}{N_s}$$

This will be the required closed loop bandwidth of the commutation loop.

Now the maximum phase lead should occur when the open loop gain crosses unity, which will yield the maximum phase margin. Since the open loop gain varies with rotor speed, the best place to put the maximum phase lead is the geometric mean between the maximum rotor speed and the startup speed at the end of the ramp period. If the commutation loop closes after the ramp period at a speed of 100 RPM, then:

$$F_{VCO} = 0.05 \times N \times \sqrt{100 \times \text{MAXRPM}}$$

Where N is the number of poles, and MAXRPM is the maximum operation speed of the motor. Using the equation for ω_{MAXLEAD} and the above:

$$\sqrt{M} \times \omega_z = -2 \times \ln\left(\frac{1}{100}d\right) \times \frac{F_{VCO}}{N_s}$$

Or:

$$\omega_z = -2 \times \ln\left(\frac{1}{100}d\right) \times \frac{F_{VCO}}{(N_s \times \sqrt{M})}$$

Now returning to the original open loop gain equation, and noting that at the ω_o frequency, the magnitude must equal 1, we get:

$$K_o \times \frac{\left| j \times 2 \times E \times \frac{F_{VCO}}{N_s} + 2 \times E \times \frac{F_{VCO}}{N_s \sqrt{M}} \right|}{\left(\left| j \times 2 \times E \times \frac{F_{VCO}}{N_s} \right| \right)^2 \times C1 \times \left| j \times 2 \times E \times \frac{F_{VCO}}{N_s} + 2 \times E \times \sqrt{M} \times \frac{F_{VCO}}{N_s} \right|} = 1$$

Where $E = -\ln(d/100)$. Solving for $C1$ yields:

$$C1 = \frac{1}{4} \times \frac{K_o}{\sqrt{M}} \times \frac{N_s^2}{\left(\ln\left(\frac{d}{100}\right)^2 \times F_{VCO}^2 \right)}$$

Then $C2$ is just:

$$C2 = C1 \times (M - 1)$$

And substituting back into the equation for ω_z :

$$2 \times E \times \frac{F_{VCO}}{(N_s \times \sqrt{M})} = \frac{1}{\frac{1}{4} \times \frac{K_o}{\sqrt{M}} \times \frac{N_s^2}{(E^2 \times F_{VCO}^2)} \times (M - 1) \times R}$$

Solving for R and simplifying:

$$R = 2 \times M \times \ln\left(\frac{d}{100}\right) \times \frac{F_{VCO}}{N_s \times K_o (1 - M)}$$

The following table summarizes the constants used in the equations for R , $C1$ and $C2$.

The phase margin is given by the following expression:

$$\Phi_m = \text{atan}(\sqrt{M}) - \text{atan}\left(\frac{1}{\sqrt{M}}\right)$$

This is dependent only on the spread between the pole and the zero, because the uncompensated phase is 180 degrees due to the two poles at the origin. With $M = 10$, the maximum phase margin will be 55 degrees. These values should provide good performance in most applications.

As an example, consider a motor with 12 poles, $K_o = 0.269$, a decade of separation between the pole and zero, 20 PLL cycles to settle to 3% of final value, and (min and max) RPM = 5400. First, the number of poles and the RPM require that $F_{VCO} = 3240\text{Hz}$. The value for ω in the formula for K_o should be based on the geometric mean between starting speed and operating speed. Plugging these values in for $C1$, $C2$ and R , we get:

$$C1 = 0.228 \times \mu\text{F}$$

$$C2 = 2.055 \times \mu\text{F}$$

$$R = 4.691 \times \text{K}\Omega$$

TABLE 1.

CONSTANT	DESCRIPTION	FORMULA	RECOMMENDED VALUE
F_{VCO}	VCO frequency for mean motor speed (see text).	$F_{VCO} = 0.05 \times N \times \text{RPM}$	Depends on motor and application
M	Spread between pole and zero in loop filter.	$\omega_p = M \times \omega_z$	10-20
d	PLL will settle to d percent in N_s PLL cycles	$t_s = \frac{-\ln\left(\frac{d}{100}\right)}{\zeta \times \omega_n}$	3
N_s	The number of PLL cycles necessary to settle to d percent after a step of phase	$t_{acq} = \frac{N_s}{F_{VCO}}$	20
K_o	The motor back EMF constant, in V/rad/S times the VCO gain, in Hz/V (note the unit change and the absence of the $2 \times \pi$ in the denominator), times the angular speed of the rotor, in rad/s times the back EMF attenuation constant, times the gm of the phase detector's transconductance amplifier.	$K_o = K_e \times K_v \times \omega \times \text{Atten} \times g_m$ K_e is supplied by the motor manufacturer The VCO gain is $K_{VCO \text{ MIN}} = \frac{2.42 \times 10^{-6}}{C_{VCO}}$ The angular speed of the rotor is the expressed in r/s. The back EMF attenuation (Atten) is the divider hooked between the motor and the PH1-3 back EMF sense inputs, (Nominally 0.5), and g_m is $1.25E-4$	Depends on motor and application

Plotting the Bode response of the filter alone:

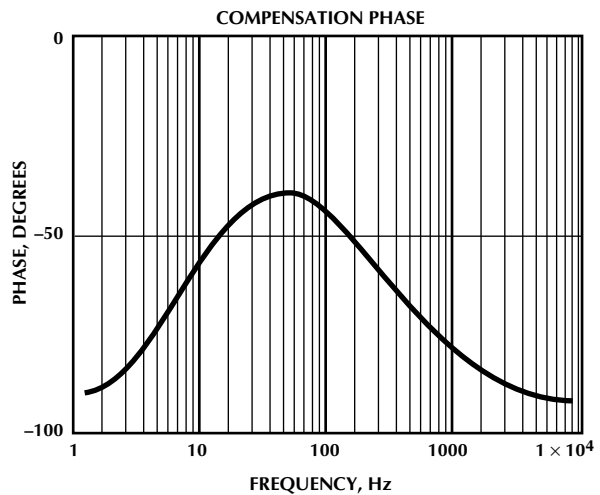
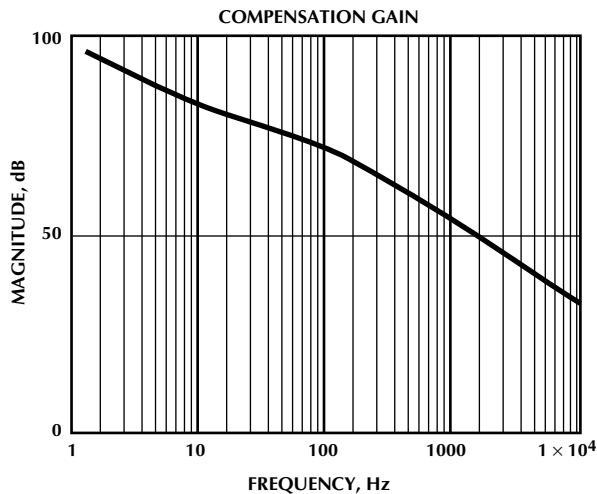

Application Note 43

This clearly shows the phase boost due to the compensation, and the rolloff to filter the VCO frequency. Now the overall loop bandwidth is calculated from the preceding equations to be 181Hz. The overall open loop gain and phase are shown in the following graphs:

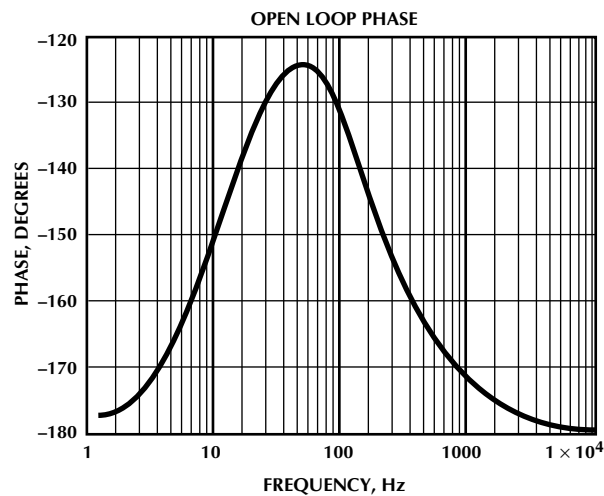
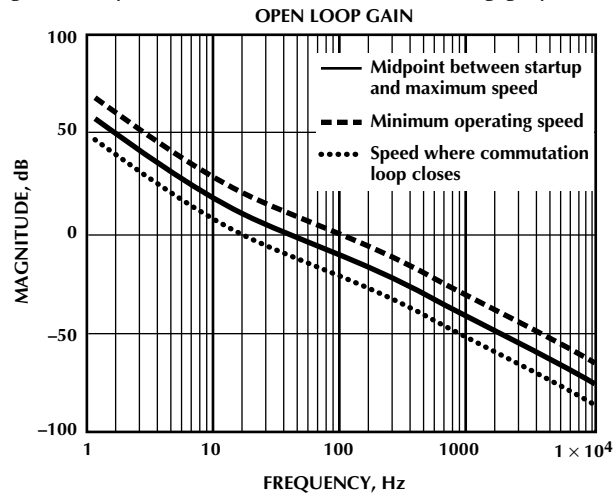

As expected, the open loop gain at the center frequency crosses 0dB when the phase peaks, giving a bandwidth of approximately 180Hz and a phase margin of 55 degrees. The phase margin at startup and at nominal speed are also better than 40 degrees. For variable speed applications, the phase margin will remain within these limits, provided the nominal speed is chosen to be the maximum speed, and the speed is controlled downward from there. Using this approach, the rotor speed can vary more than an order of magnitude and still maintain acceptable phase margin.

RAMP CAPACITOR

If you do not encounter startup problems, it is not necessary to include C_{RAMP} , on pin 21. If you have a large inertial load with low damping and high motor speed you should read the following section. The ML4425/ML4426 output a fixed $0.5\mu A$ current on pin 20 during ramp up. This is the input to the VCO. Therefore, the rotor's acceleration is a function of the current, VCO gain and the loop filter components only. In some cases, where the VCO capacitor is small due to a high running speed, and the motor inertia is large, the rotor may not be able to follow the VCO during ramp up. In these cases, it is necessary to add a capacitor from pin 21 to ground. This capacitor is switched in during ramp only, and allows the rate of acceleration during ramp up to be lowered. An approximate starting point for this capacitor is given by the following equation:

$$C_{RAMP} = \frac{J \times 0.5 \times 10^{-6}}{I_{MAX} \times Kt} \times \frac{Kv \times 2 \times \pi}{3 \times N} - (C1 + C2)$$

Where J is the inertia of the motor plus load, Kv is the VCO gain, N is the number of poles, I_{MAX} is the maximum motor current, Kt is the torque constant, and C1 and C2 are the loop filter components on pin 20. Normally, the result of the preceding equation will be a negative number, meaning that no ramp capacitor is necessary. If the result of this equation is greater than zero, then the ramp capacitor should be included.

Cosc

This capacitor sets the PWM ramp oscillator frequency. This is the PWM "switching frequency". If this value is too low, <20KHz, then magnetostriction effects in the motor may cause audible noise. If this frequency is too high, >30KHz, then the switching losses in the output drivers may become a problem. 25KHz should be a good compromise for this value, which can be obtained by using a 1nF capacitor.

R_{VCO} AND R_{REF}

R_{VCO} should be 80K and R_{REF} should be 137K for normal operation.

RC_{PWM}

This pin is the output of a transconductance amplifier. A resistor and a capacitor in series with this pin and connected to ground form the speed loop compensation. The motor will have a mechanical time constant, given approximately by:

$$\tau_m = \frac{J \times R_w}{K_e^2}$$

Where J is the moment of inertia of the rotor plus the load, R_w is the winding resistance, and K_e is the back- E.M.F. constant. This pole occurs at a relatively low frequency, and will limit the frequency of response of the servo loop. In order to get better response, the RC combination on the RC_{PWM} pin can be used to provide phase lead for the speed loop. This combination also sets the open loop gain characteristics, and therefore the accuracy of the speed loop. In order to pick components for this loop, it is necessary to decide on a desired closed loop bandwidth. The chosen closed loop bandwidth should be substantially lower than the bandwidth of the phase locked loop used for commutation, in order to preserve acceptable phase margin. This is usually not a problem, as the mechanical time constant of the motor is necessarily much lower than the commutation loop response. Depending on the motor and its load, a bandwidth in the 1–10Hz range is easily achievable. The frequency of the compensating zero should be set to be a decade below the unity gain crossover frequency, so that its contribution to the phase lead will be maximum at the crossover. The following formula gives the value of C necessary for these conditions:

$$CC = 482.314 \times N \times \frac{V_{CC} \times C_{VCO}}{\left[\text{freq} \times \left[K_e \times \left(\sqrt{2.5 + 98.696 \times \tau_m^2 \times \text{freq}^2} \right) \right] \right]}$$

Where freq is the desired unity gain crossover frequency, V_{CC} is the supply voltage, C_{VCO} is the VCO capacitor on pin 15, N is the number of poles in the motor, and the other quantities are defined above.

Then, the value of R should be

$$R = \frac{10}{2 \times \pi \times CC \times \text{freq}}$$

If the speed loop is unstable, it is possible that the desired bandwidth is too high, and reducing the value of freq. should solve the problem.

BACK EMF ATTENUATION RESISTORS

If you use the ML4425/ML4426 with a motor supply which is higher than 12V, you must divide down the back EMF signals from the motor so as not to exceed 12V on the phase sensing inputs, PH1, PH2 and PH3. The ML4425/ML4426 have internal 8K resistors to ground, so an external resistance in series with each phase and the respective phase sense input forms a voltage divider. (See Figure 6) This divider is the Atten constant in the previous formulas for picking the loop filter. For example for a 100V motor, the series resistors should give 12V at the input to the part for the absolute maximum input voltage. Choosing 110V as the maximum voltage to allow some safety margin gives a divider ratio of 12/110 or 0.109. A series resistor of 80.6K gives a safe ratio of 0.09.

OUTPUT DRIVE

The ML4425/ML4426 can drive external N and P channel FET's directly, if 12V operation is used. For voltages between 24V and 80V, an external cascode transistor can be used to level shift the drive voltages. For higher voltages, or large currents, external drivers, coupled with all N-channel FET's are the best solution. (IGBT's could be used as well.) The external FET's used with the part should be rated to handle the full current limit current plus appropriate derating. They should stand off at least 1.5–2 times the motor supply voltage. Thermal considerations and heatsinking are important and should be given consideration in the preliminary design phase. In some applications, when a velocity loop is closed around a motor, and there is a large inertia attached to the motor, during deceleration the energy stored in the inertia can cause the motor to generate a current. This current will pump up the power supply capacitors to a potentially dangerous voltage, causing capacitor and output stage failure. If this is a problem, the solution is to add a circuit which senses when the supply voltage increases by a given amount and switches a resistive load into place to dissipate the energy. This problem does not occur when braking, but the N-channel FET's must handle most of the energy in the rotating mass if braking is necessary. The brake function should not be used with high voltage high energy motors.

Application Note 43

DRIVING MOTORS UP TO 80V

The schematic of Figure 5 shows how to drive motors up to 80V using a cascode approach. The external bipolar transistors stand off the higher voltage, and level shift the high side drive. The reason that this approach is restricted to 80V is the availability of high voltage P channel FET's is limited, and the cost is high. It may be possible to use this approach with higher voltage motors if higher voltage P channel FET's can be obtained.

DRIVING HIGH VOLTAGE MOTORS

An example of one way to drive a high voltage motor is shown in Figure 6. The IR2130 provides the interface and drive capability for the larger FET's. The floating supply powers the 3 high side drive circuits. In the application notes for many of the FET drivers they show a "flying capacitor" approach to developing drive for the high side N-channel devices. This circuit connects a diode from the +12V rail to a capacitor, which has the other end hooked to the motor phase output. The "flying capacitor" charge pump scheme will not work with the ML4425/ML4426, since during the reset period, the high side drives turn on first, and remain on for the reset duration. This does not allow the "flying capacitor" to charge. One possible solution for this problem is to turn on the brake momentarily before starting the motor, so that the lower N channel devices will turn on and charge the bootstrap capacitor before the reset period. This can be accomplished automatically with a one shot and some logic gates. It is important to be sure that the voltage on the capacitor does not droop significantly during the reset phase. Another possible solution is shown in Figure 6. This solution generates three isolated voltage supplies for driving each of the high side FET's. The CMOS inverter shown is configured as an oscillator to drive a small toroidal core with three secondary windings. The secondary windings are rectified by bridge rectifiers and filtered with filter capacitors. The bridge rectifiers supply a very small average current and can be tiny SOT-143 type devices.

LAYOUT CONSIDERATIONS

Good layout practices are vital to getting the ML4425/ML4426 to work reliably. In particular, the supplies must be well decoupled close to the chip with 0.1 μ F ceramic capacitors in parallel with 1 μ F electrolytic or tantalum capacitors. The supply to the output drivers must also be well decoupled close to the drivers with at least a 0.1 μ F in parallel with a good quality low ESR 10 μ F electrolytic. High current motors may require more capacitance. Controlling the current paths is important as well. If a groundplane is used, separate conductors (traces) should return the motor currents to the sense resistor which can connect to the ground plane near the supply ground. The same approach should be used for the supply voltage. The purpose of this technique is to keep the high current high speed signals out of the ground plane, to reduce system noise. If the supply voltage input is not near the power decoupling caps for the drivers, additional supply decoupling should be used where the supply enters the board. Watch capacitive coupling from high dv/dt signals into traces or planes on other layers. Use multiple vias to connect high current traces from the top of the board to the bottom. Standard layout practice applies to the rest of the circuit. Keep traces as short as possible, minimize high current loop length, etc.

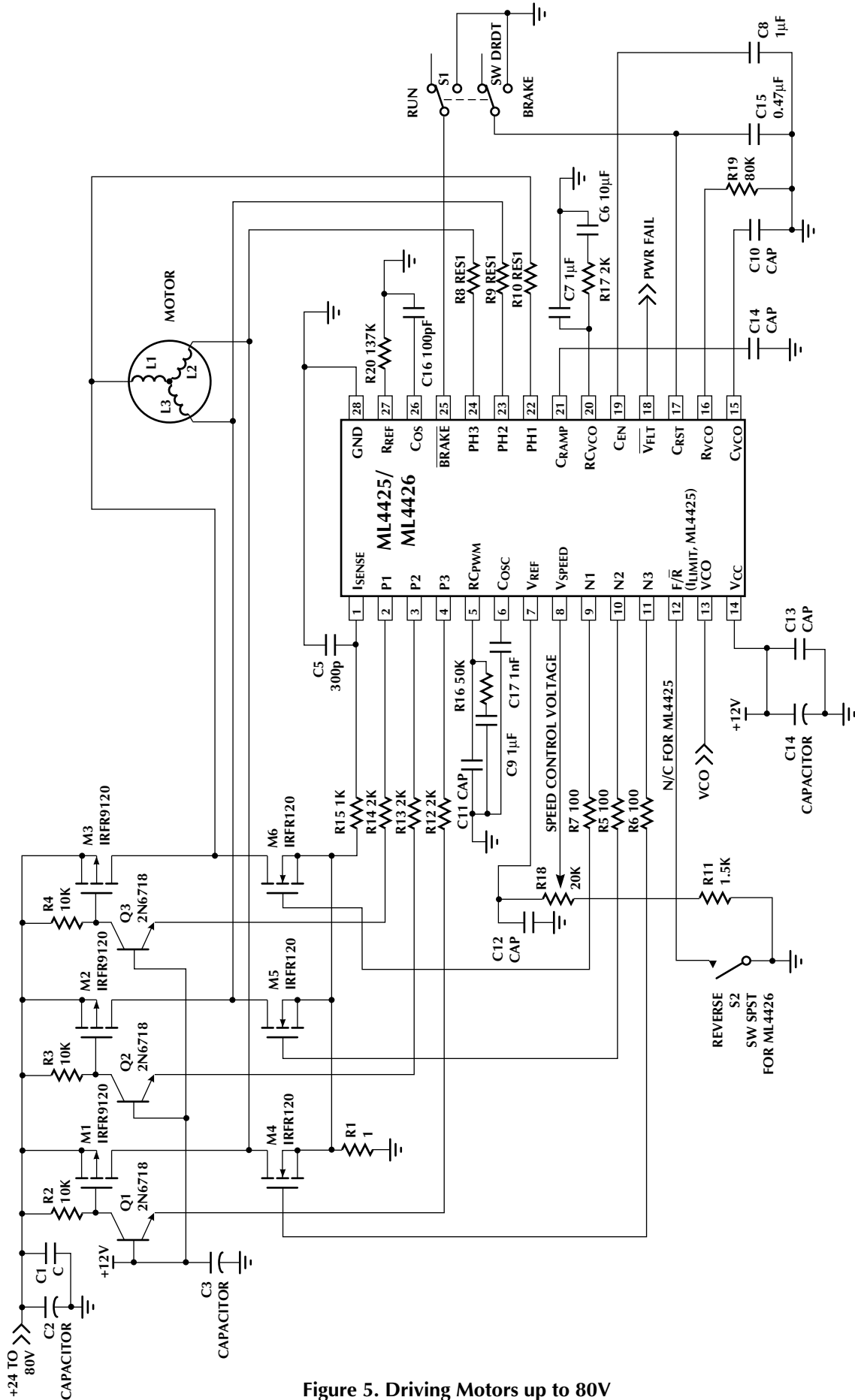

Figure 5. Driving Motors up to 80V

