

Application Note 42013

Ram Gopalan
Tom DeLurio

Active SCSI Terminator — Important Issues Capacitance & Power Dissipation

INTRODUCTION

The SCSI bus is essentially a cable that can be as simple as a flat ribbon cable or as advanced as shielded differential twisted pairs. For this reason, a well-designed active termination is important for reliable data transfer between the Host/Initiator (motherboards, host adaptor add-on cards etc.) and up to seven Targets which could be hard disk drives, CD-ROMs, tape drives, scanners, etc. along 72 feet of cable at 10 MB per second. No easy task considering the complexities of each device and the varying impedance of some of the cheaper cables that are available. Micro Linear's active terminator has been designed to exhibit much lower capacitive loading compared to other competing devices while optimizing the V-I characteristics. This document compares the ML6509 to the offerings from Texas Instruments and Dallas Semiconductor and outlines the capacitance measurement used to get the values. Also provided is a thermal study for the 16 pin SOIC and 20 pin TSSOP packages and a discussion of the device's thermal shut-down mode.

TERMINATOR CAPACITANCE ISSUE

Disconnect capacitance is a very important specification for an active SCSI terminator. The SCSI bus is a transmission line environment and is terminated at the two ends of the bus. Any device in between must not be terminated or it will load down the bus and the system may be subjected to data integrity problems due to double clocking etc. All SCSI devices must have the capability to be terminated so that they can be used anywhere on the bus. Hence an existing termination must either be physically pulled off the SCSI device (such as a passive termination) or the termination must be logically disconnected when a device no longer requires termination. An active termination has the advantage of having a control pin to disconnect the terminator but it is still physically connected to the bus. The underlying problem is that the disconnected device must not add too much capacitance when turned off. The added capacitance may violate the SCSI specification for total capacitive loading at that node and any distributed capacitance along a transmission line, will also alter the bus impedance.

The X3T9.2/855D, revision 12, SCSI-3 document recommends a procedure for measuring pin capacitance

in Annex E. The objective of this procedure is to determine the lumped capacitance imposed on each signal conductor of the bus proper by a SCSI device connected thereto. The model for this procedure assumes the bus in the ribbon cable form, passing through an insulation-displacement SCSI connector, the mating part that is mounted on a SCSI device controller printed-wire board. The bus connector is removed from the device, along with every source of power. One or more device connector circuit-common pins are connected together to form an effective circuit-common node. An R-F admittance bridge (or equivalent), operation at 1 MHz is connected successively to each signal pin in the device connector, with reference to the circuit-common node. The signal applied during measurement is biased to 0.5V D.C. and is 0.4V peak to peak in amplitude. The characteristics are determined in terms of parallel combination of a conductance and a capacitive susceptance which corresponds to the capacitance referred to in the SCSI standard.

RESULTS OF CAPACITANCE MEASUREMENT USING GENERAL TECHNIQUE

An experiment was conducted in the lab where the ML6509 disconnect capacitance was compared to the Dallas DS2107S and Texas Instruments TI 2218-285. The test setup to make the capacitance measurements is shown in figure 1 and consisted of an HP model 4275A Multi-Frequency LCR meter and a test fixture. The test frequency was a 10 MHz square wave (to emulate fast SCSI speeds), an oscillation level at 0.7V and the meter biased at 2V. The DUT was powered-up and in disconnect mode. Each pin was measured with respect to ground. In order to cancel the effect of the capacitance due to the socket, probes, the meter etc., each test socket pin was measured empty and the value subtracted from each DUT pin measurement to cancel the contribution from them.

The results of the experiment are summarized in Table 1. As can be seen, the DS2107S offers a capacitance per termination line of approximately 23 pF at the node, while the TI2218-285 offers a capacitance per termination line of approximately 10 pF at the node. The ML6509 offers an average capacitance per termination line of approximately 4.5 pF at the node. The ML6509 production test will guarantee this capacitance to be below 5 pF on each line (rev C). The capacitance value significantly change the characteristic impedance of the cable and cause reflections which results in lowering the data integrity on the bus. Under the same test conditions, the TI part is

Application Note 25

relatively better than the DS2107S but is still worse than the ML6509.

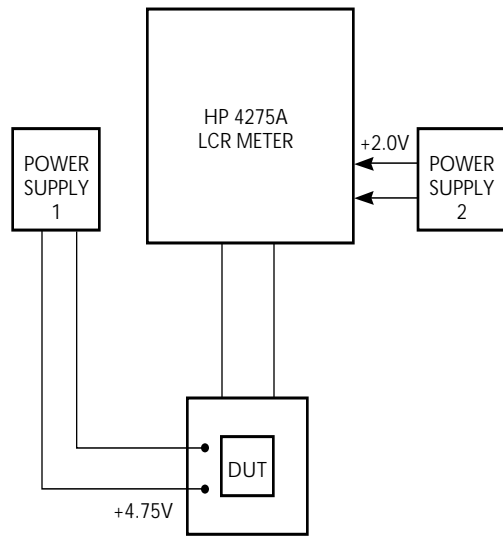

Figure 1. Test Setup

TABLE 1 CAPACITANCE MEASUREMENTS (pF) USING GENERAL TECHNIQUE

Termn Line #	ML6509 TSSOP (REV C)	ML6509 SOIC Rev		DS2107S SOIC	TI2218-285 TSSOP
		B	C		
L1	4.6	7.1	3.7	23.3	12.0
L2	3.8	6.6	3.9	23.6	11.8
L3	4.4	6.6	3.8	23.6	10.8
L4	4.8	6.4	3.9	23.5	9.5
L5	4.8	6.8	3.9	23.5	10.9
L6	4.8	6.8	4.1	23.3	9.5
L7	4.9	7.5	4.0	23.5	10.6
L8	4.8	9.0	4.1	23.6	10.7
L9	4.3	9.0	3.9	23.7	11.0

RESULTS OF CAPACITANCE MEASUREMENTS USING ANSI RECOMMENDED TECHNIQUE

The same experiment was conducted to measure disconnect capacitance of the ML6509, Dallas DS2107S and Texas Instruments TI 2218-285 in accordance with the ANSI recommended technique. The test frequency was a 1 MHz square wave, an oscillation level at 0.4 V_{p-p} and the meter biased at 0.5V. The DUT was powered-up and in disconnect mode. Each pin was measured with respect to ground. In order to cancel the effect of the capacitance due to the socket, probes, the meter etc., each test socket pin was measured empty and the value

subtracted from each DUT pin measurement to cancel the contribution from them.

The results of the experiment are summarized in Table 2. As can be seen, the DS2107S offers an average capacitance per line of approximately 30 pF at the node, while the TI2218-285 becomes inductive as observed by the negative readings, which could imply problems of a different kind on the SCSI bus. The ML6509 offers an average capacitance per line of approximately 6.5 pF at the node with this measurement technique. Hence under the same test conditions, the TI part is the worst as it turns inductive, the DS2107S part is much better than the TI part but is still no match for the ML6509 at 7 pF average per line.

TABLE 2 CAPACITANCE MEASUREMENTS (pF) USING ANSI TECHNIQUE

Termn Line #	ML6509 TSSOP REV C	ML6509 SOIC REV C	DS2107S SOIC	TI2218-285 TSSOP
L1	6.0	6.9	33.0	-292
L2	6.5	6.9	33.1	-277
L3	6.5	7.1	33.2	-277
L4	6.8	7.1	33.3	-271
L5	6.7	7.1	32.7	-268
L6	7.0	7.3	25.5	-311
L7	7.0	7.3	25.9	-312
L8	6.7	7.0	25.8	-264
L9	6.2	7.0	25.9	-305

POWER DISSIPATION ISSUE THERMAL MEASUREMENTS

The AC power dissipation characteristics of an active terminator are described somewhat differently than what is commonly used for a standard integrated circuit. This is because SCSI terminators are not specified with respect to capacitive loading. The device does no "drive" a capacitive load at a stated frequency because as mentioned earlier, SCSI is a transmission line environment which theoretically has zero capacitance if terminated with the lines' characteristic impedance. When an output is active, it is at a logic low (0.2V) and sources 24mA. When inactive at a logic high (2.85V), the output sources only 0.5mA. If all outputs are low, the part sources 216mA. This seems extreme and it is under dc conditions. Fortunately, in actual use, all nine outputs are held low for no more than 50 ns at a time in a 10MBps SCSI bus system on the two most active lines, /REQ and /ACK. Also,

on average, only 50% of the outputs will be low at the same time for that short duration.

The ML6509CT device in the TSSOP has a heat sink internally on which the die is set. The heat is dissipated through the heat sink pins 2, 8, 12, 18.

The ML6509 also has a low power mode for driving small cable lengths or for use in portable applications. In this mode, the terminator only sources 1mA per output. When the device is in disconnect mode, it does not draw more than 100 μ A, and in standby mode when the outputs are high, not more than 5mA is used by the device. This is much less than the constant current that flows through a resistor divider in a passive termination.

To determine the average junction temperature for a SCSI device, the following equation for Maximum Junction Temperature (T_j) is used:

$$T_j = (\theta_{ja}) (P_d) + T_A$$

where:

$$\text{Maximum } P_{d_{LOW}} = (5.5V - 0.2V) (24mA) (9) = 1.15W$$

$$\text{Maximum } P_{d_{HIGH}} = (5.5V - 2.8V) (0.5mA \times (9)) = 0.012W$$

$$\text{Maximum } T_A = 70^\circ\text{C} \text{ (} 25^\circ\text{C is room temperature)}$$

P_d is the power dissipation and is minimal with all outputs high, but increases rapidly in the low state. Normally, P_d is calculated with the equation CV^2f which increases with frequency(f), but for this device the thermal resistance is used as the value that varies with time. It is measured versus the duration of active low output time which raises the junction temperature of the die. Determining thermal resistance of the part in a system is estimated by the total amount of time that all 9 outputs are low. At 10 MBytes per second on the SCSI bus under normal conditions, the time the die is actually heated will be much less than 1 second and off the lower end of the chart (less than 30°C/W). This would cause junction temperature to be 104°C as given by:

$$T_j = (30^\circ\text{C/W}) (1.16W) + 70^\circ\text{C} = 104.8^\circ\text{C}$$

assuming Ambient Temperature (T_A) is 70°C .

The T_j of 104°C predicts an MTBF of over 1800 years. If

all outputs are stuck low and the die is heated to a steady state and reaches a thermal resistance of 107°C/W , the junction temperature will reach 194°C and MTBF will be unacceptable. To prevent damage to the device, the ML6509 has a thermal shutdown feature that disables the outputs when a junction temperature of 170°C is reached. A possible extreme scenario would be if all lines are stuck active low for 70 seconds and the ambient temperature is 70°C , then T_j is given by:

$$T_j = 87^\circ\text{C/W} (1.16W) + 70^\circ\text{C} = 170^\circ\text{C}$$

and then part thermal shutdown circuitry will disable the outputs.

GRAPH 1

This chart shows the plot of heating time versus thermal resistance. The Heating Time on the bottom axis represents the amount of time that all 9 outputs are tied active low which heats the die. Thermal resistance (θ_{ja}) on the vertical axis increases over time and reaches a steady-state of 107°C/W after 500 seconds under zero airflow conditions. The corresponding die junction temperature rises according to the equation

$$T_j = (\theta_{ja}) (PD) + T_A$$

GRAPH 2

This chart provides the Mean Time Between Failures (MTBF) versus Junction Temperature (T_j). After calculating the average Junction Temperature at which the device will be operating, MTBF can be used to determine the effective lifetime of the device.

SUMMARY

The ML6509 Active SCSI Terminator offers the lowest capacitance (5 pF) in the industry today and is the only SCSI Terminator chip where the capacitance spec is guaranteed through production test. The ML6509 uses industry standard packages and supports an internal heat sink to handle the power dissipation. The data presented shows how the power dissipation issue can be handled and in the worse case the onboard thermal shutdown circuitry gets activated when the junction temperature reaches in the ballpark of 170°C hence preventing a catastrophic failure. Please contact Micro Linear's application engineering department, if you need any assistance with SCSI Terminators.

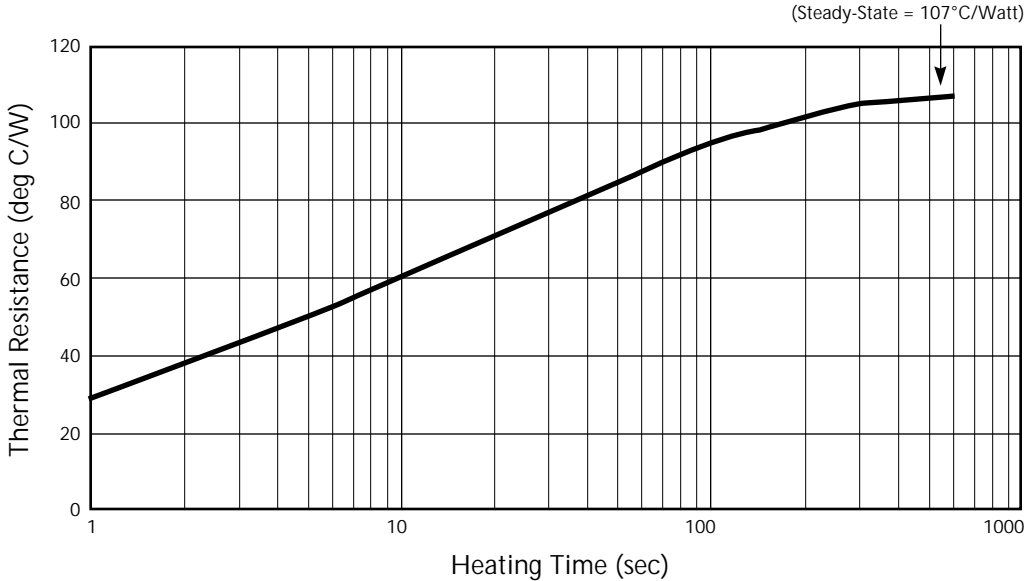

Graph 1. Shows the Heating Time vs Thermal Resistance (θ_{ja}) for the TSSOP package.

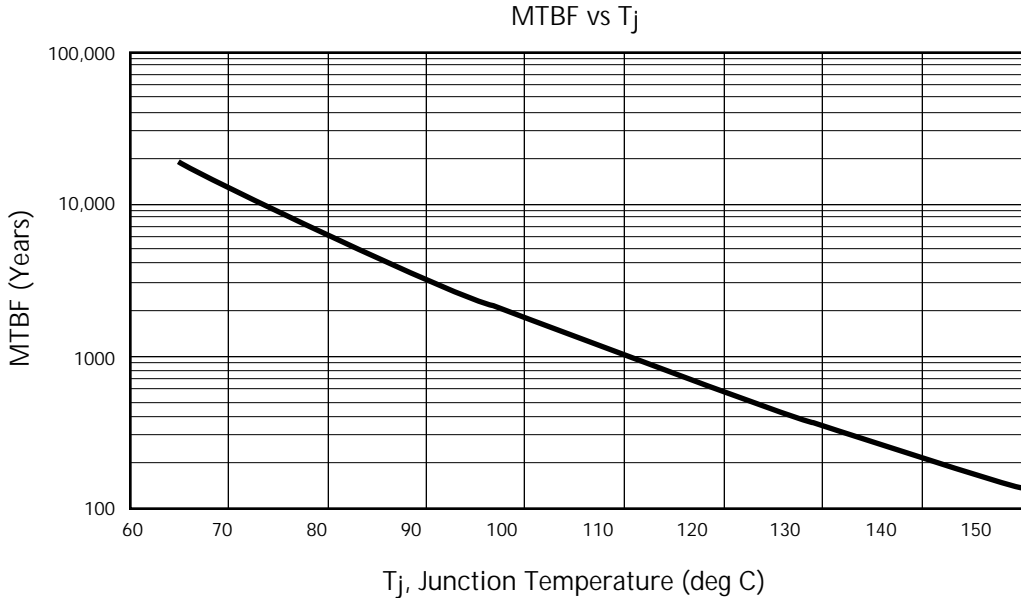

Graph 2. Shows the Mean Time Between Failures (MTBF) vs Junction Temperature (T_j) for the TSSOP package.

DISCLAIMER

FAIRCHILD SEMICONDUCTOR RESERVES THE RIGHT TO MAKE CHANGES WITHOUT FURTHER NOTICE TO ANY PRODUCTS HEREIN TO IMPROVE RELIABILITY, FUNCTION OR DESIGN. FAIRCHILD DOES NOT ASSUME ANY LIABILITY ARISING OUT OF THE APPLICATION OR USE OF ANY PRODUCT OR CIRCUIT DESCRIBED HEREIN; NEITHER DOES IT CONVEY ANY LICENSE UNDER ITS PATENT RIGHTS, NOR THE RIGHTS OF OTHERS.

LIFE SUPPORT POLICY

FAIRCHILD'S PRODUCTS ARE NOT AUTHORIZED FOR USE AS CRITICAL COMPONENTS IN LIFE SUPPORT DEVICES OR SYSTEMS WITHOUT THE EXPRESS WRITTEN APPROVAL OF THE PRESIDENT OF FAIRCHILD SEMICONDUCTOR CORPORATION. As used herein:

1. Life support devices or systems are devices or systems which, (a) are intended for surgical implant into the body, or (b) support or sustain life, and (c) whose failure to perform when properly used in accordance with instructions for use provided in the labeling, can be reasonably expected to result in a significant injury of the user.
2. A critical component in any component of a life support device or system whose failure to perform can be reasonably expected to cause the failure of the life support device or system, or to affect its safety or effectiveness.