



Application Note AN-5064

Low- I_{CCT} Analog Switches for Ultra-Portable Designs

Summary

Fairchild Semiconductor has revolutionized and enhanced the design of analog switches to meet the demand for ultra-portable products, such as cell phones. Greater integration and improvements in the process technology involves using different voltage rails to power and control the analog chipset. To solve this problem, Fairchild, a leading analog switch supplier, has introduced new analog switches and begun to offer modified versions of existing products. This new generation of analog switches offers an expanded control input range, while maintaining low current consumption and rail-to-rail signaling. This application note discusses the underlying reasons behind the shift in design styles and how the new solutions meet the needs of these ultra-portable systems. Additionally, it discusses a new generation of low- I_{CCT} analog switches specifically designed to prolong battery life in ultra-portable devices and the design trade-offs made to improve performance over mixed voltage rails and enhance the total system performance.

Ultra-portable products, such as cell phones, PDAs, or MP3 players, use analog switches in a variety of applications, from USB port sharing and isolation to audio switching. After choosing a switch relative to configuration and application-specific requirements, there are several key specifications that ultra-portable designers consult regardless of the end application.

Ultra-portables rely on a battery supply, making power consumption a major factor in the selection of an analog switch. In most ultra portable systems, there are multiple supply rails available, and designers use a power management IC to detect which supplies are present. The power management IC chooses to supply the analog directly from the battery or from a regulated supply. Depending upon the situation, the supply voltage could range from 2.7V to 3.6V, in the case of a regulated supply from the wall, or 4.3V V_{CC} when powered from a fully charged battery.

Until recently, the on-board General Purpose Input Output (GPIO) control voltage levels corresponded to the supply voltage rail powering the analog switch. This resulted in very little current consumption by the switch. Under these conditions, it is standard for analog switches to have less than $1\mu A$ of current consumption. When the ultra-portable product is operating from the battery supply, total current consumption becomes very important. In a standard configuration (Control = 0V or V_{CC}), analog switches are well within the typical power budget with less than $1\mu A$ of current consumption.

Newer ASIC designs have migrated to smaller process geometries, limiting their voltage handling capabilities. As a result, system designers have had to step down the ASIC supply voltage from the power management IC to an acceptable level. In many cases, the ASIC requires a 2.6V to 2.8V supply, which limits the maximum output voltage for the GPIO signal. The GPIO signal is generally used to drive the analog switch control pin. When the standard analog switch is powered directly by the battery and the GPIO voltage is in the 2.6V to 2.8V range, this leads to excessive current consumption by the switches. The excess current can be as high as several milliamps, depending on the design of the particular switch. For portable devices already operating on a tight power budget, several milliamps of current consumption is unacceptable. Most standard analog switches specify only ICC consumption of the typical condition where the input control voltage is equal to the supply voltage. This has caused confusion among many system designers who were surprised to find milliamps of current as they migrated to lower-voltage ASICs. Low- I_{CCT} analog switches are designed to operate in this type of application. Figure 1 relates the application differences that would lead a designer to use one of the new low- I_{CCT} switches.

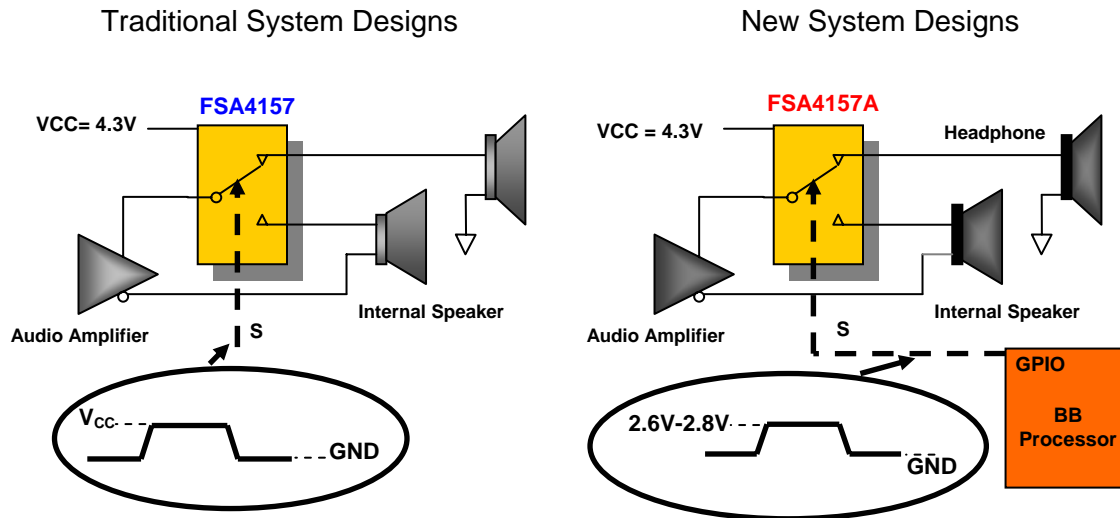

Note: Low- I_{CCT} parts should be used when GPIO voltages are below the analog switch supply level.

Figure 1. An Audio Switching Application

Figure 1 illustrates the key differences between traditional system designs using FSA4157 and newer system designs using the FSA4157A. It shows that, for the first case, the select pin HIGH state is driven to the same V_{CC} rail powering the FSA4157. In this configuration, current consumption is typically less than $1\mu A$. In newer system designs, the select pin is no longer driven to the V_{CC} rail of the FSA4157A, but is limited by the supply rail of the ASIC. In this configuration, a standard analog switch current consumption is typically greater than $1mA$.

CMOS control circuitry input buffers have very little current consumption when the control input is at $0V$ or V_{CC} . While the datasheets specify that the switch recognizes the control as a HIGH or LOW as long as the control signal input is held at a level that is greater than V_{IH} minimum and less than V_{IL} maximum, they do not specify what the current consumption is when the control voltage is not at $0V$ or V_{CC} . Although the control logic selects the correct output state when the control signal is within the required V_{IH} and V_{IL} bounds, the farther away from the rail the control voltage is, the greater the current consumption.

The analog switch should maintain low power consumption for rail-to-rail signaling, while allowing an expanded input control range. To meet this need, Fairchild developed a line of low- I_{CCT} switches. These parts are specifically designed to be used in mixed voltage rail environments.

This low current consumption is not only included on new switches designed for ultra-portable applications, but on all new analog switch products designed for ultra-portable applications. The analog switch team has issued "A" versions of select existing analog switches used in similar applications. These parts can still be operated directly from the $4.3V$ battery supply, but it is no longer necessary to have the control input equal to V_{CC} to maintain low power consumption. Even for applications where the battery supply is always regulated down to $3.6V$, the current consumption of a standard analog switch is excessive when select is less than the switch supply rail and a low- I_{CCT} version is needed.

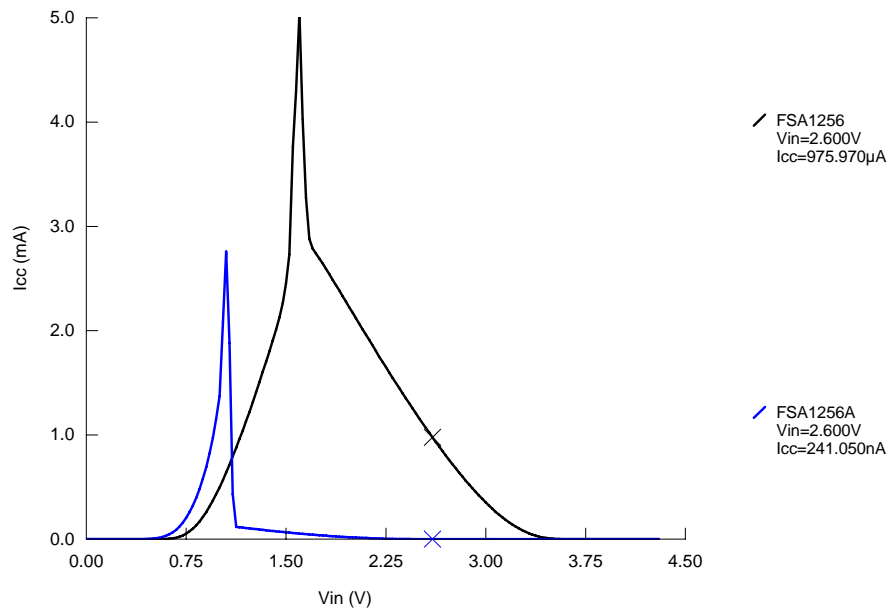

Figure 2. I_{CC} vs. V_{IN} for Low- I_{CC} Switches vs. Traditional Analog Switches, FSA1256 and FSA1256A

Figure 2 is a transfer curve of the new generation analog switch overlaid on the same plot as a traditional switch. It shows that, while the current spike is still present, it is shifted to the left and the peak magnitude is reduced. In the new low- I_{CC} switches, the total current consumption is much less than $10\mu\text{A}$ when $V_{CC} = 4.3\text{V}$ and control = 2.6V . This is a vast improvement over standard analog switches. For portable applications using mixed voltage rails with limited GPIO driving capabilities, these switches offer a low-power solution.

With improved performance, there are some trade-offs. First, the control input switching threshold is shifted down on the newer switches. This can be seen in shift of the location of the current spike in Figure 2. Furthermore, these newer "A" products have slightly greater Turn On (t_{ON}) and Turn Off (t_{OFF}) times as well as a slight increase in the minimum V_{CC} supply range. For current applications, neither trade-off negatively impacts the system performance. For typical low- I_{CC} products, the minimum

supply voltage increases from 1.65V to 2.3V . This is typically not an issue because very few ultra-portable designs have less than a 2.3V supply available to power the analog switch. Furthermore, since analog switches do not consume much power (about $1\mu\text{A}$), a higher power rail ($> 2.3\text{V}$) is preferred by designers to achieve lower On Resistance. For typical audio switching or USB application, low R_{ON} is very important. The increase in t_{ON} and t_{OFF} is insignificant in most application because the increased switching time is much less than what is required.

In conclusion, the advantages gained by using the new low- I_{CC} analog switches are significant. For newer battery-supplied ultra-portable designs, this new generation of analog switches is an essential part of the ultra-portable designer's tool kit. These products help designers stay within the power budget and ensure long battery life. To view a complete listing of all Fairchild's analog switch portfolio, please refer to the analog switch page at: www.fairchildsemi.com/analogswitch.

DISCLAIMER

FAIRCHILD SEMICONDUCTOR RESERVES THE RIGHT TO MAKE CHANGES WITHOUT FURTHER NOTICE TO ANY PRODUCTS HEREIN TO IMPROVE RELIABILITY, FUNCTION, OR DESIGN. FAIRCHILD DOES NOT ASSUME ANY LIABILITY ARISING OUT OF THE APPLICATION OR USE OF ANY PRODUCT OR CIRCUIT DESCRIBED HEREIN; NEITHER DOES IT CONVEY ANY LICENSE UNDER ITS PATENT RIGHTS, NOR THE RIGHTS OF OTHERS.

LIFE SUPPORT POLICY

FAIRCHILD'S PRODUCTS ARE NOT AUTHORIZED FOR USE AS CRITICAL COMPONENTS IN LIFE SUPPORT DEVICES OR SYSTEMS WITHOUT THE EXPRESS WRITTEN APPROVAL OF THE PRESIDENT OF FAIRCHILD SEMICONDUCTOR CORPORATION.

As used herein:

1. Life support devices or systems are devices or systems which, (a) are intended for surgical implant into the body, or (b) support or sustain life, or (c) whose failure to perform when properly used in accordance with instructions for use provided in the labeling, can be reasonably expected to result in significant injury to the user.
2. A critical component is any component of a life support device or system whose failure to perform can be reasonably expected to cause the failure of the life support device or system, or to affect its safety or effectiveness.