



AN-6022 Using the FSUSB30/31 to Comply with USB 2.0 Fault Condition Requirements

Introduction

Designers adding enhanced Hi-Speed USB functionality to their systems using the Fairchild's FSUSB30/FSUSB31 switches products often ask, "How do I ensure that I fully comply with the USB standard?" Many initially chose the FSUSB30/31 because of the superior signal handling characteristics, low power consumption, and small packaging options. In addition to maintaining excellent signal integrity, the FSUSB30/31 must protect against a Vbus short circuit to fully comply with the USB 2.0 specification. The following is found in section 7.1.1 of the USB 2.0 specification:

Short-Circuit Withstand

A USB transceiver is required to withstand a continuous short circuit of D+ and/or D- to VBUS, GND, other data line, or the cable shield at the connector, for a minimum of 24 hours without degradation. It is recommended that

transceivers be designed to withstand such short-circuits indefinitely. The device must not be damaged under the short-circuit condition when transmitting 50% of the time and receiving 50% of the time (in all supported speeds). The transmit phase consists of a symmetrical signal that toggles between drive HIGH and drive LOW. This requirement must be met for max value of VBUS (5.25 V).

The maximum V_{CC} supply of the FSUSB30/31 is limited to 4.6V. At first glance, one might think that a switch would have an issue meeting the USB requirement. This conclusion are correct for standard analog switches without Fairchild's Power-Off Protection circuit, but the FSUSB30/31 is the first USB switch to offer this protection. If properly configured, the FSUSB30/31 fully meet the USB requirements for short-circuit withstand. There are two distinct cases in which the USB system could experience this fault condition. The first case is when the switch powered off and the second is when the chip is powered on.

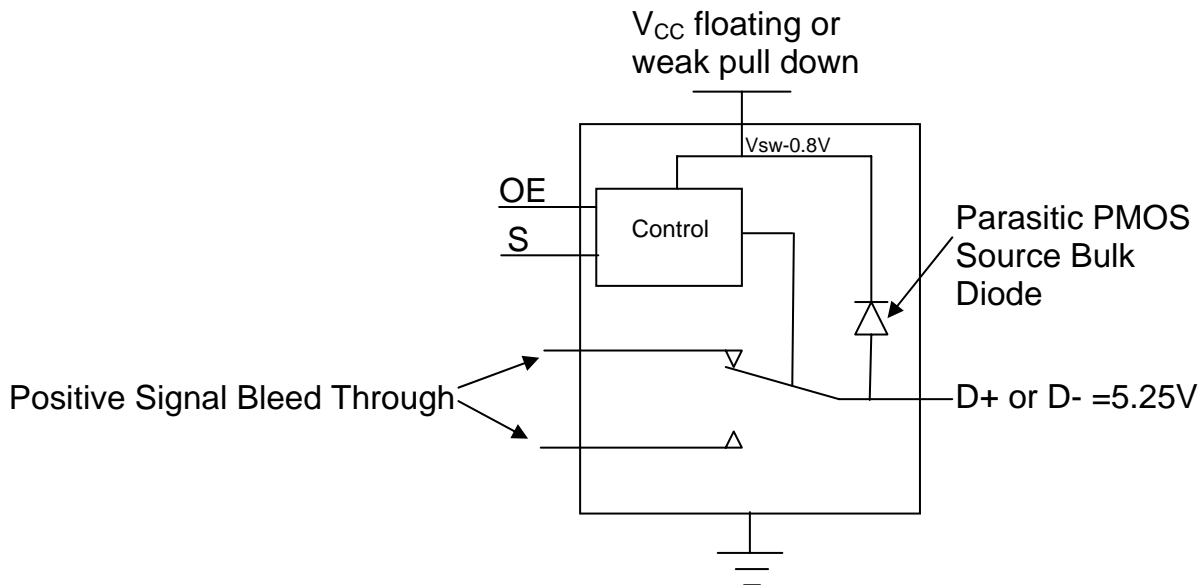

Figure 1. A Typical Analog Switch Application with Signal Bleed Through

Power-Off Protection

For an unprotected analog switch to fully guarantee correct functional state based on the control inputs, it must be powered on. When a positive data signal appears on such a switch input before the switch has fully turned on, there is a no guarantee that the signal will be handled correctly. Unless the analog switch has specially designed circuitry to guarantee off isolation when powered off, the signal can bleed through. Signal bleed through can even occur on both output pins simultaneously of a single pole double throw switch regardless of the OE and S pin states. Using an unprotected switch to share a common USB port between two different host controllers could result in a false enumeration sequence of the un-selected controller if positive signal were unintentionally passed through the switch. When the V_{CC} pin is floating or very weakly pulled down, it is possible for the switch input signal (D+, D-) to power up the switch internal circuitry, allowing the signal to bleed through the switch. This can be seen in Figure 1, where the switch internal V_{CC} node is indicated as $V_{sw-0.8V}$. With the internal node powered up, the switch turns on and passes the input signal. In this case, it is possible for a positive voltage to appear on the unselected output.

Often the USB switch is placed on the system periphery and used to separate internal components from the outside world. In the USB short-circuit example, the switch is also expected to withstand such a condition for long periods of time (at least 24 hours). On an unprotected switch where the positive input voltage is sustained, it may also lead to irreversible damage to the analog switch. This damage could result from excessive current flowing from the switch input ports to a grounded switch V_{CC} pin. This current path is a result of the inherent switch parasitic PMOS bulk diode, which acts like a forward biased diode when the input voltages are greater than $V_{CC} + 0.5V$. The diode requires a minimum forward voltage to conduct, which is typically assumed to be approximately 0.5V. This effective diode allows excessive current to flow through the chip into the V_{CC} pin. The greater the voltage on the input pin, the greater the current. This voltage-current relationship is exponential and can be represented with an ideal diode curve. As a result, the maximum current rating of the chip can quickly be exceeded. Once a part has been damaged from an over-voltage event, the part often continues to exhibit excessive leakage and may no longer function, even when inputs are returned to normal operating conditions. Figure 2 illustrates the current path formed between the data input pin and V_{CC} just described.

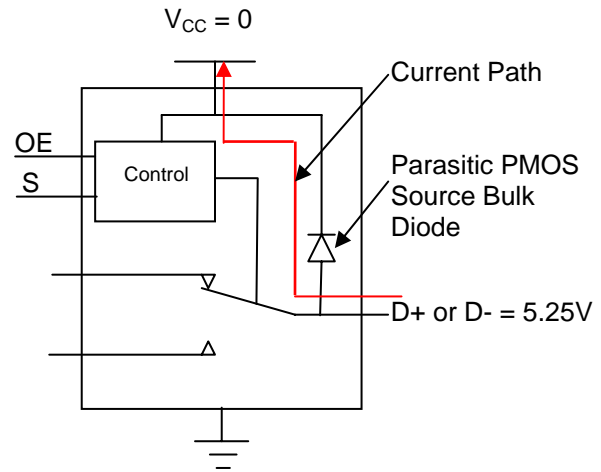

Figure 2. Typical Analog Switch Current Leakage Path when in an Over-Voltage Condition

The FSUSB30/31 have specially designed circuitry that prevents unintended signal bleed through as well as guaranteed system reliability during a power-down over-voltage condition. When $V_{CC}=0V$, the switches isolate the input signal from the outputs regardless of the state of the enable pins or the select pins, preventing unintended signal bleed through. It also protects against current leakage from the signal pin into the supply pin. The input signal sees a high-impedance input when the switch is powered down and the parasitic PMOS bulk diodes are prevented from being forward biased. It is important to note that the FSUSB30/31

Power-Off protection is on the common port (D+, D-). The protection has been added to the common pin because connector sharing is the most common application need. In that situation, the common port is the only port which could experience a V_{bus} short circuit. Therefore, based on Fairchild's understanding of the USB application, Power-Off Protection was added to these two I/O pins. See Figure 3 for a common port-sharing application example.

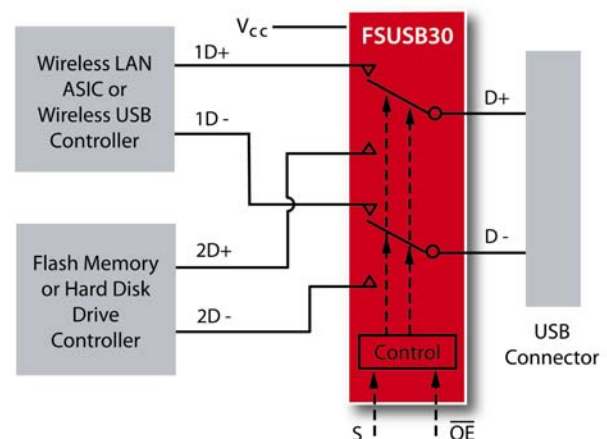

Figure 3. Typical Connector Sharing Application

Power-On Protection

The USB 2.0 specification also notes that the USB device should be capable of withstanding a Vbus short during transmission of data. Because the USB switch must be powered on to transmit data, it also should be able to withstand up to 5.25V on the D+ or D- pins when powered on. It is acceptable for D+, D- to exceed V_{CC} by 0.5V; however, any voltage in excess without other circuit modification can lead to reliability failures and should be avoided. For example, if the switch is powered by $V_{CC}=3.6V$ and D+ or D- experience a 5.25V Vbus short, neither a standard analog switch nor a Power-Off Protected switch can guaranteed reliable operation unless the circuit is modified. In this powered up case, the SPDT switch ensures that the unselected output does not have any unintended signal bleed through on un-selected ports. Excess current, as depicted in Figure 2, is a real problem, but a simple schematic modification solves this problem. Inserting a 100Ohm series resistor between the switch V_{CC} pin and supply rail protects the switch against damage during a powered up Vbus short. This modification works by limiting current flow back into the V_{CC} rail during the over-voltage event so current remains within the safe operating range. In this application, the switch passes the full 5.25V input signal through to the selected output. For this reason, all components in the USB data path must be able to withstand this powered on 5.25V Vbus short condition. Finally, the datasheet limits should be observed for design during normal operation whether the parts are powered up or down. Figure 4 illustrates the board design modification that allows the FSUSB30/31 to fully meet the USB 2.0 specification.

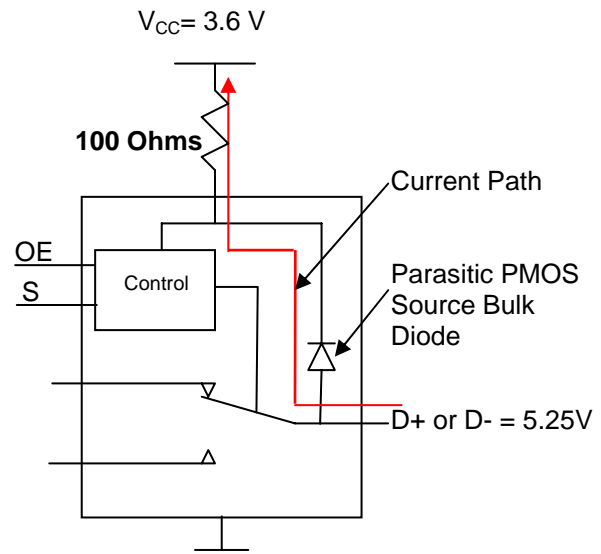

Figure 4. By adding 100 Ohms in series with the V_{CC} supply, the FSUSB30/31 can withstand a Vbus short when powered up

Conclusion

The FSUSB30/31 are the first production-released product to fully incorporate Power-Off Protection, which helps protect against the powered off Vbus fault condition described in the USB specification. With the addition of a simple 100Ohm series resistor between the V_{CC} pin and V_{CC} supply, the FSUSB30/31 can withstand a Vbus short when powered up.

DISCLAIMER

FAIRCHILD SEMICONDUCTOR RESERVES THE RIGHT TO MAKE CHANGES WITHOUT FURTHER NOTICE TO ANY PRODUCTS HEREIN TO IMPROVE RELIABILITY, FUNCTION, OR DESIGN. FAIRCHILD DOES NOT ASSUME ANY LIABILITY ARISING OUT OF THE APPLICATION OR USE OF ANY PRODUCT OR CIRCUIT DESCRIBED HEREIN; NEITHER DOES IT CONVEY ANY LICENSE UNDER ITS PATENT RIGHTS, NOR THE RIGHTS OF OTHERS.

LIFE SUPPORT POLICY

FAIRCHILD'S PRODUCTS ARE NOT AUTHORIZED FOR USE AS CRITICAL COMPONENTS IN LIFE SUPPORT DEVICES OR SYSTEMS WITHOUT THE EXPRESS WRITTEN APPROVAL OF THE PRESIDENT OF FAIRCHILD SEMICONDUCTOR CORPORATION.

As used herein:

1. Life support devices or systems are devices or systems which, (a) are intended for surgical implant into the body, or (b) support or sustain life, or (c) whose failure to perform when properly used in accordance with instructions for use provided in the labeling, can be reasonably expected to result in significant injury to the user.
2. A critical component is any component of a life support device or system whose failure to perform can be reasonably expected to cause the failure of the life support device or system, or to affect its safety or effectiveness.