



AN-6088

FAN5902 Power Management Solution for Improving the Power Efficiency of 3G WCDMA RF Power Amplifiers

Abstract

This application note provides the basics for implementing a Dynamic Voltage Scaling (DVS) power management technique with 3G WCDMA RF power amplifiers (PAs) to improve the overall power efficiency and increase the average talk-time in 3G handsets.

The DVS technique scales the power supply level of the PA output stage according to the output RF power level using a high-efficiency DC-to-DC converter, such as the FAN5902, specifically designed for that purpose.

This application note illustrates the advantages of the DVS technique and provides information to help designers understand its hardware and software implementation.

Background

3G PAs in WCDMA/UMTS 3G handsets and data cards are required to operate in linear bias conditions to maintain a good signal-to-noise ratio (SNR), especially for high uplink bit rate modulation schemes, such as QAM; and prevent inter-modulation between adjacent channels.

The WCDMA/UMTS PA is the biggest source of power consumption in a 3G phone because it is continuously enabled during the communication and can drain up to 650mA rms in poor connection conditions, which discharge any Li-Ion battery in less than two hours.

One of the challenges for PA design engineers is to achieve a high Power Added Efficiency (PAE) without compromising the signal fidelity. In practice, a good 3G PA can barely achieve 35% to 40% at maximum RF output power, which means that a large amount of power is wasted and transformed into heat.

The other challenge is to prevent the collapse of the PAE as the RF power level decreases. Several techniques have been employed to reduce the PA bias current at lower power levels, but the challenge remains in controlling the variations of the insertion gain over the full output power range (from -50dBm to 28dBm).

The trends in the market today show higher interest in using a Dynamic Voltage Scaling (DVS) technique instead of variable bias-current techniques because DVS enables higher granularity of the power savings and has less impact on the variations of RF insertion gain.

The questions answered in this document are:

- How to implement the DVS technique by using a DC-to-DC converter, like the FAN5902;
- What are the hardware and software requirements for the PA, the RF chipset or baseband (BB) processor, and the DC-to-DC to implement a DVS power management scheme; and
- How to quantify the power savings achieved with the DVS using a DC-to-DC compared to a multi-power mode PA.

Power Consumption of 3G WCDMA PAs

WCDMA PAs used in 3G transmitters are required to provide an output power level from -50dBm up to 28dBm. The power level of 3G user equipment, cell phone or data card, is dynamically and smoothly adjusted upon request from the base station (BTS) to equalize the RF power level received at the BTS from all users. The user equipment has the capability of varying the power level in steps of 1dB.

Most PAs are designed to achieve maximum power efficiency at maximum output power. For instance, a good PA is capable of 40% power efficiency at 28dBm (630mW); it generates an output power of 630mW and wastes 945mW, which is transformed into heat.

The efficiency decreases as the RF output power level decreases. Most PAs are implemented with two or three power modes where the bias current of the PA is stepped down to reduce the power consumption at lower RF power levels and improve the PAE, as illustrated in Figure 1 for a typical PA.

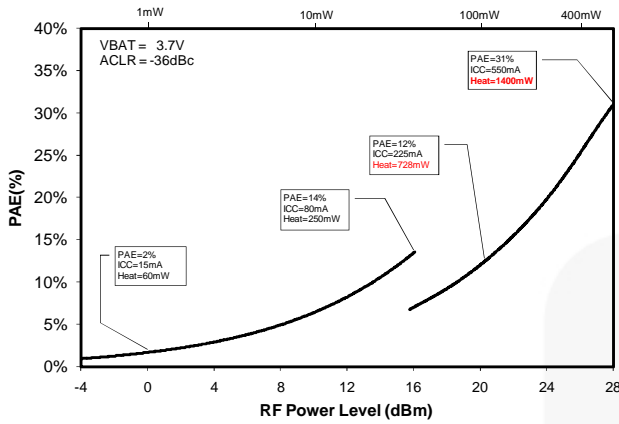

Figure 1. Power Added Efficiency (PAE) Variations in a Two-Mode WCDMA PA

Modern 3G PAs are designed to support a variable power supply level for the power amplifier stage, allowing better power savings across the entire output power range. This technique, called Dynamic Voltage Scaling (DVS), requires a high-efficiency and adjustable output voltage DC-to-DC converter (such as the FAN5902) inserted between the battery and the PA (see Figure 2).

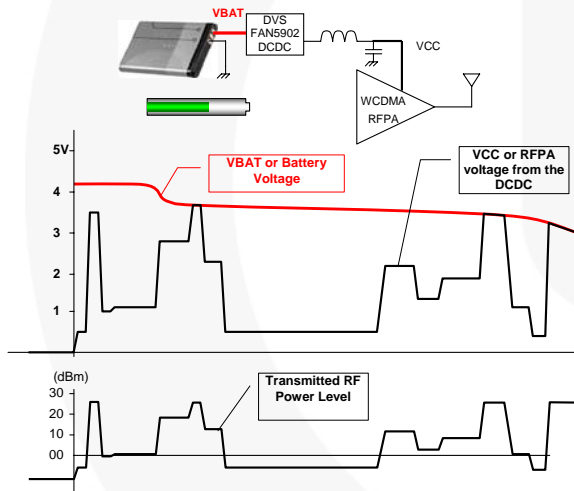

Figure 2. Dynamic Voltage Supply for 3G RF PA Using a DC-to-DC Converter

Several handsets recently released in the market have proven that DVS provides the maximum transmitter power efficiency and enables the longest talk-time for 3G transceivers.

Figure 3 illustrates the difference between the power efficiency for a classic dual-power-mode PA and a DVS-based PA using the FAN5902.

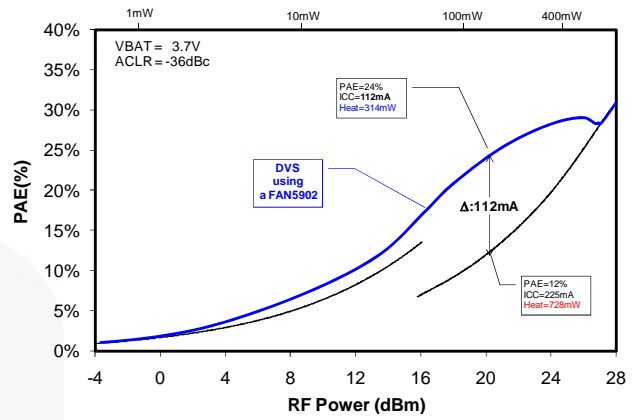

Figure 3. Power Added Efficiency (PAE) of Dual-Mode WCDMA PA with Integrated Duplexer (Black Curve) Compared to a Single-Mode PA Using Dynamic Voltage Supply (Blue Curve)

Noise Specifications for WCDMA PAs

The linearity requirement for WCDMA PAs is dictated by the tolerated noise level generated by the amplifier’s non-linearities in the Tx and Rx bands. The noise level generated in the Tx band is specified by the Adjacent Channel Leakage Ratio (ACLR). The 3GPP user equipment specification requires the transmitter to achieve an ACLR below -33dBc to prevent interference with handsets operating in adjacent channels and to guarantee proper signal demodulation by the base station.^[1*]

On the other hand, the noise level generated by the transmitter in the Rx band is an internal concern for the mobile transceiver itself because it increases the noise floor of the receiver and degrades its input SNR. Most designs require the Rx noise to remain below -135dBm/Hz.

Both ACLR and Rx noise increase when the supply voltage of the PA is scaled down (assuming constant P_{OUT}), which means that the implementation of the DVS technique has to ensure none of those parameters exceed the specified maximum limits. The sections below discuss the hardware and software implementation requirements of the DVS.

Average Talk-Time in 3G Handsets

The average talk-time has been used, thus far, as the metric by service providers and cellular phone manufacturers to compare or set targets for design performances. The talk-time or the connection time is obtained by dividing the battery capacity in mAh by the average current consumption. The carriers can provide reference usage profiles that describe users’ habits in their daily activity when utilizing their cell phones. These profiles help hardware designers determine the average current consumption for each

* (ETSI 3GPP TS34.121).

component; the display, application processor, RF modem, and the PA.

The power consumption of the PA depends on the Tx RF power usage statistics or the user profile: When a user is in a good coverage area, the cell phone reduces the output power, which reduces the current consumption. In the same manner, when a user is in a bad coverage area, the output power level is increased accordingly, which impacts the power consumption of the transmitter. It is possible to determine the average current consumption of the RF transmitter by using the user profile statistics provided by the network carriers.

User profiles are often specific and proprietary for each carrier, but an estimation of the average current consumption of the PA can be achieved using a typical user profile data published by the 3GPP DG09 work group, shown in Figure 4.

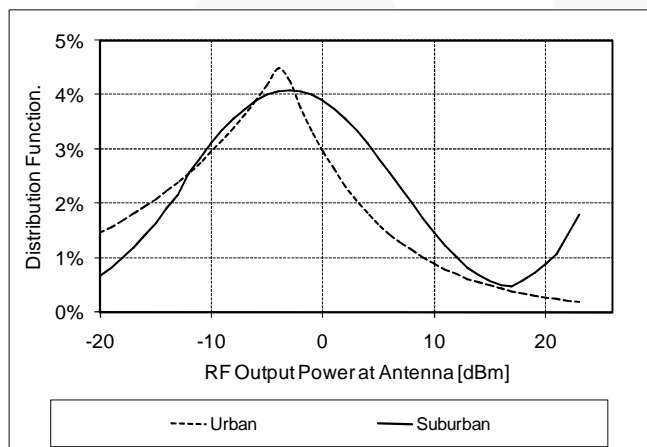

Figure 4. Tx Power Distribution Functions for 3G User Profiles in Urban and Suburban Areas

The calculation of the PA average current consumption is illustrated in Table 1. The second column shows the current consumption I_{CC} of a PA as a function of each output power level. The third column shows the statistical occurrence or the power distribution function (P_{DF} in %). The PA average current consumption is obtained by integrating the product $I_{CC} \times P_{DF}$ for all the power levels. The average talk time is obtained by adding the PA average current to the other component's current consumption (rest of radio) and dividing the battery capacity by the total average current of the handset.

The average talk-time is meaningful for the service providers because it defines the overall service performance for their handset portfolios. Furthermore, while consumers may not be aware of the technical issues influencing the talk time, they are very aware which phones promise the maximum operation time between recharges.

Table 1. Average Current Consumption

RF P_{OUT} at Antenna (dBm)	PA I_{CC} Supply Current (mA)	Power Distribution Function or P_{DF} (%)	$I_{CC} \times P_{DF}$ (mA)
26	650	0.10	0.65
25	600	0.15	0.90
24	500	0.20	1.00
1	26	2.50	0.65
0	25	3.00	0.75
-5	20	4.40	0.88
-10	15	3.00	0.45
-50	15	1.00	0.15
			Sum of above
Average PA Current Consumption			32mA

Talk Time for Data-Centric Phones

The quick adoption of data-centric handsets, such as multimedia mobile handsets and smartphones, over the last two years caused the industry to revisit a legitimate question about the actual connection-time for the handset, rather than the talk-time.

Several sources reported that the PA output power level would shift up for data-centric phones or for indoor connections by approximately 10dB, which would result in a significant increase of the PA current consumption and reduce the connection-time.^[1,2]

Most PAs have been optimized to operate at a low-power level, which covers a big percentage of users living or working in urban areas with a voice-centric profile. However, data-centric users have specific needs for longer connectivity and fewer recharges. The PA has to be optimized to lower power consumption *within* the mid and high PA power levels using DVS because the discrete level changes alone are optimal only at the transition points. Consequently, many handset manufacturers and PA suppliers have adopted DVS power management solution to enhance PA power in such conditions.

Dynamic Voltage Scaling Technique

The output stage of a WCDMA/UMTS PA is usually made of a power GaAs HBT or HEMT transistor dimensioned to remain linear for output powers up to 28dBm. This stage is traditionally supplied directly from the battery through the pin V_{CC2} , as illustrated in Figure 5. PAs can have a high-power mode supporting an output power level between 16dBm and 28dBm and a low-power mode for power levels below 16dBm. A bias control circuit is used to step down the bias current of the output stage and improve the power efficiency around 16dBm, as shown in Figure 1. This might require two mode control pins (three or four levels) and a variable bias input to switch between the power modes and adjust the PA linearity for the low-power mode.

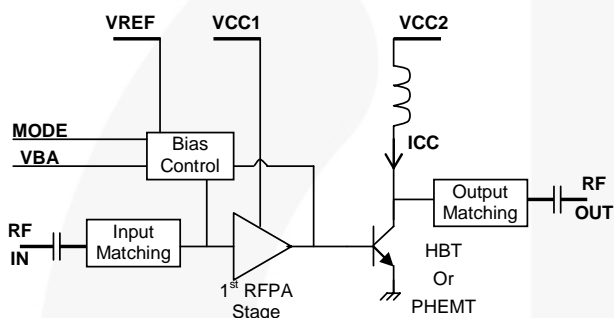

Figure 5. Block Diagram of a Typical WCDMA PA

The DVS technique consists of using a single power mode PA and scaling the collector bias voltage V_{CC2} down as the RF power level decreases. A high-efficiency DC-to-DC converter with an adjustable output voltage, such as the FAN5902, is required to smoothly adjust the V_{CC2} supply voltage and achieve the highest PA power efficiency over the entire RF output power range, as illustrated in Figure 2.

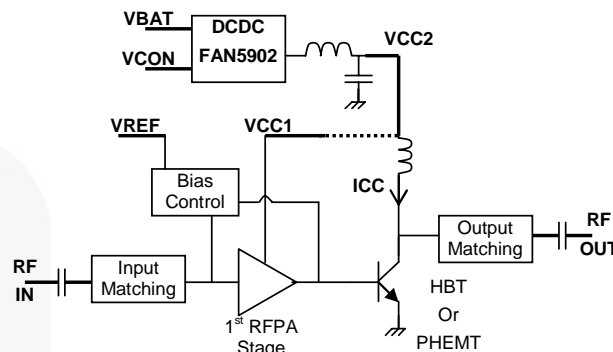

Figure 6. Block Diagram of a Typical WCDMA PA with a DC-to-DC Converter

DVS Implementation with the FAN5902

Figure 7 shows a DVS power management scheme using the FAN5902 DC-to-DC converter. The PA is configured to always be in high-power mode while the supply voltage V_{CC2} is provided by the FAN5902 and controlled by the baseband processor DAC output.

The BB processor determines for each Tx time frame the required PA output power level and sets V_{CON} to generate the appropriate minimum supply voltage V_{CC2} that maintains the PA linearity.

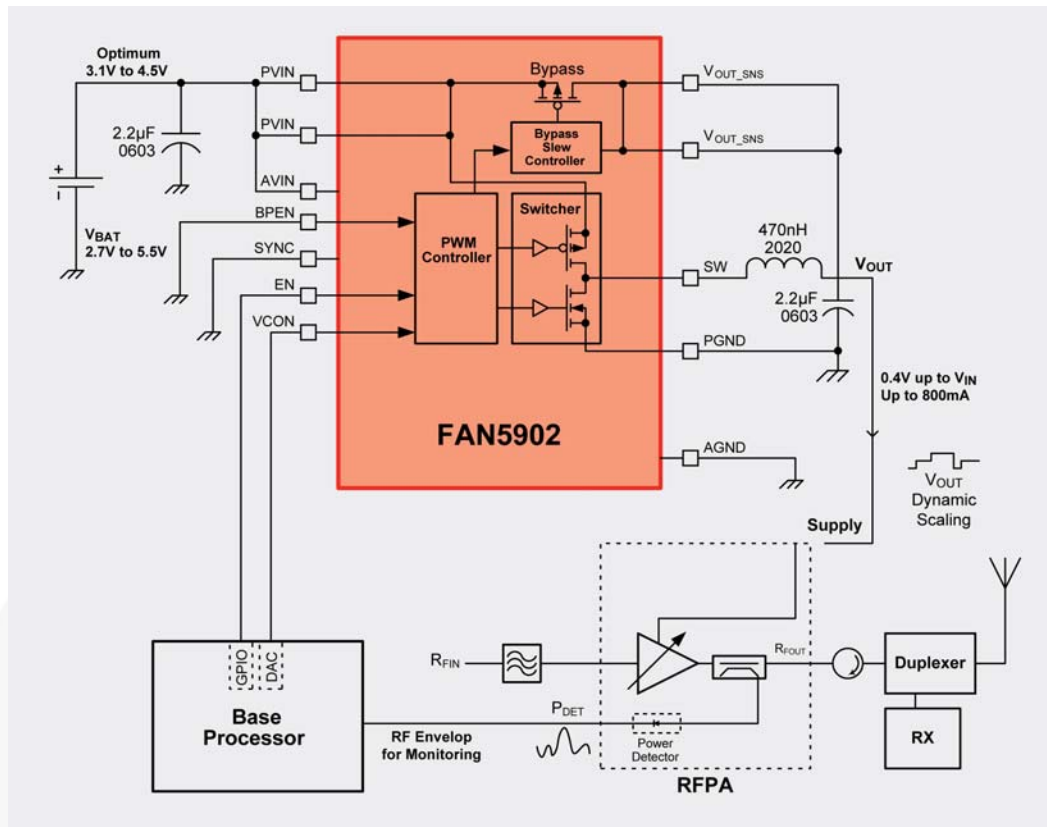

Figure 7. Typical Implementation of DVS for Improving PAE in WCDMA/UMTS RF Front-End

Such implementation requires the handset PA designer to establish a lookup table that tells what the minimum supply voltage should be for each Tx power level. The lookup table must be embedded in the firmware or the algorithm controlling the Tx power.

The control algorithm should operate synchronously with the Tx power controller. The supply voltage of the PA can only be changed during a 25µs time window prior to the instant the Tx data packet is sent on the air.

The benefits of the FAN5902, a fully featured power-management solution for WCDMA PAs, include:

- The output voltage V_{OUT} can be scaled from 3.4V for maximum RF power down to 0.4V for minimum RF power. Combined with 800mA load current capability, it covers most PA specifications, even in bad antenna-mismatch conditions.
- The output voltage V_{OUT} is set to $2xV_{CON}$, which makes it compatible with 1.8V rail DACs.
- When the battery voltage falls close to the desired V_{OUT} , the FAN5902 automatically connects the PA to the battery through a 50mΩ $R_{DS(ON)}$ bypass FET. It allows maximum usage of the battery power down to 3.1V (see the FAN5902 datasheet for details).
- A built-in voltage limiter prevents V_{OUT} from dropping below 0.4V or exceeding 3.4V (except when the bypass mode is enabled). This protects the PA and prevents extra heating at high battery voltage.
- The output voltage transition time is lower than 20µs, which matches the timing of the RF power control according to the 3GPP specifications^(†).
- The high switching frequency (6MHz) allows using a 2mm x 1.6mm 0.447µH inductor, which is considered the smallest form-factor solution available. It does not pollute the Tx and Rx UMTS frequency bands since the switching frequency resides outside the channel bandwidth.
- For voice calls, the PA spends the majority of the time below 7dBm output power, based on the DGF-090 standard; which means low PA current consumption. The FAN5902 automatically changes to Pulse Frequency Modulation (PFM) mode under light-load conditions to further reduce current consumption from 10mA to 3mA.

^(†) ETSI 3GPP, TS 34.121, clause 5.6.2. The ETSI specification calls for 25µs time interval before the RF power level settles (see also TS 25.101, clause 6.5.3.1).

Figure 8 and Figure 9 show typical variations of the supply voltage used for a WCDMA PA to achieve an ACLR of -36dBc. The PA in this example is kept in high-power mode and the supply voltage is varied using the FAN5902. The corresponding power added efficiency is shown in Figure 9 (blue curve) and compared to the same PA directly supplied by a 3.7V battery with high and low modes.

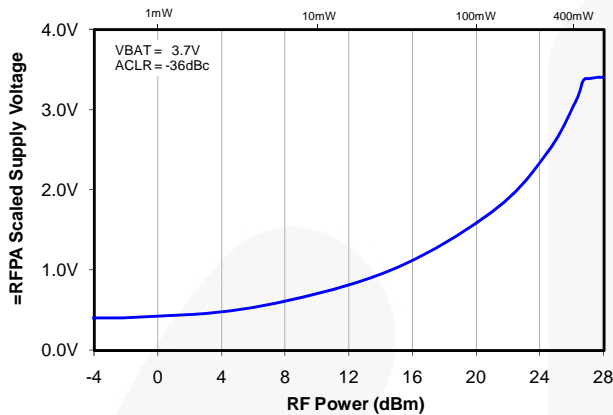

Figure 8. Typical Variations of the Supply Voltage Level Employed in a DVS Power Management Scheme for a WCDMA PA

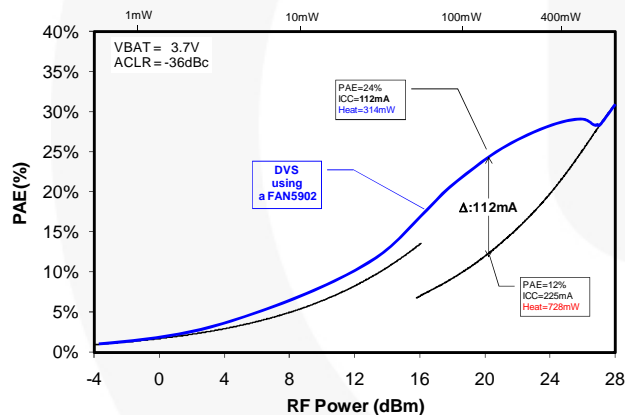

Figure 9. Improved PAE as a function of the Output Power Level for -36dBc ACLR

There is a significant battery current saving between 16dBm and 24dBm, which is valuable for data connections or for voice communications in suburban areas. Calculations show that for a user calling from a bad coverage area where the PA power settles around 20dBm, the talk or connection time extends by more than 1 hour (112mA savings).

Figure 9 also shows that there is no degradation of the power efficiency below 0dBm.

Advanced implementation schemes are possible by combining the low-power mode of the PA and the supply voltage scaling. Evaluations done by Fairchild for such implementation showed additional battery current savings of ~10mA at 0dBm and below.

Contact Fairchild Application Engineering for advanced DVS implementations.

Bibliography

- [1] B. Henshaw, "High Efficiency PA's mean more ARPU, IWPC Conf." *Next Generation Data Centric Devices, Networks, and Services*, Venice, July 2009.
- [2] A. B. Raju, "Characterization of Uplink Transmit Power and Talk Time in WCDMA Networks" Virginia Polytechnic Institute and State University, MSc EE thesis, Jan 2008.
- [3] ETSI 3GPP TS 34.121 v6.0.0, Radio transmission and reception, Technical Specification Group Terminals, 2005.

DISCLAIMER

FAIRCHILD SEMICONDUCTOR RESERVES THE RIGHT TO MAKE CHANGES WITHOUT FURTHER NOTICE TO ANY PRODUCTS HEREIN TO IMPROVE RELIABILITY, FUNCTION, OR DESIGN. FAIRCHILD DOES NOT ASSUME ANY LIABILITY ARISING OUT OF THE APPLICATION OR USE OF ANY PRODUCT OR CIRCUIT DESCRIBED HEREIN; NEITHER DOES IT CONVEY ANY LICENSE UNDER ITS PATENT RIGHTS, NOR THE RIGHTS OF OTHERS.

LIFE SUPPORT POLICY

FAIRCHILD'S PRODUCTS ARE NOT AUTHORIZED FOR USE AS CRITICAL COMPONENTS IN LIFE SUPPORT DEVICES OR SYSTEMS WITHOUT THE EXPRESS WRITTEN APPROVAL OF THE PRESIDENT OF FAIRCHILD SEMICONDUCTOR CORPORATION. As used herein:

1. Life support devices or systems are devices or systems which, (a) are intended for surgical implant into the body, or (b) support or sustain life, or (c) whose failure to perform when properly used in accordance with instructions for use provided in the labeling, can be reasonably expected to result in significant injury to the user.
2. A critical component is any component of a life support device or system whose failure to perform can be reasonably expected to cause the failure of the life support device or system, or to affect its safety or effectiveness.