

AN-8002

FMS6418B 4:2:2 Application Note

Summary

The FMS6418B offers comprehensive filtering for set-top box or DVD applications. This part consists of a triple 6th-order filter with selectable 36MHz or 8.0MHz frequencies.

4:2:2 applications are achievable with a few minor modifications; using an N-Channel FET, as an inverter, controlling two N-Channel FET's, used as switches. When FSEL is high, HD is active switching the bandwidth to 30, 15, 15MHz. When FSEL is low, SD is active switching the bandwidth to 8, 4, 4MHz.

Any combination of frequencies are achievable by changing the values of C15, C16, C17, and C18 of the 4:2:2 application schematic.

Applications

- Cable set-top boxes
- Satellite set-top boxes
- DVD players
- HDTV
- Personal Video Recorder (PVR)
- Video On Demand (VOD)

For a complete description of the FMS6418B, please refer to the FMS6418B datasheet.

Table 1. 4:2:2 Applications

DVD Player	Output Signal Format	Bandwidth (MHz)
	CV	7.1
	YC	7.1
	D1 (525i)	7.1, 3.5, 3.5
Progressive Scan DVD Player	Output Signal Format	Bandwidth (MHz)
	CV	7.1
	YC	7.1
	D1(525i)	7.1, 3.5, 3.5
	D2(525p)	15, 7.5, 7.5
Digital Hi-Vision STB	Output Signal Format	Bandwidth (MHz)
	CV	7.1
	YC	7.1
	D1 (525i)	7.1, 3.5, 3.5
	D2 (525p)	15, 7.5, 7.5
	D3 (1125i)	30, 15, 15
	D4 (750p)	30, 15, 15
PDP, Progressive TV, Normal TV	Input Signal Format	Bandwidth (MHz)
	CV	7.1
	YC	7.1
	D1 (525i)	7.1, 3.5, 3.5
	D2 (525p)	15, 7.5, 7.5
	D3 (1125i)	30, 30, 30 or 30, 15, 15
	D4 (750p)	30, 30, 30 or 30, 15, 15

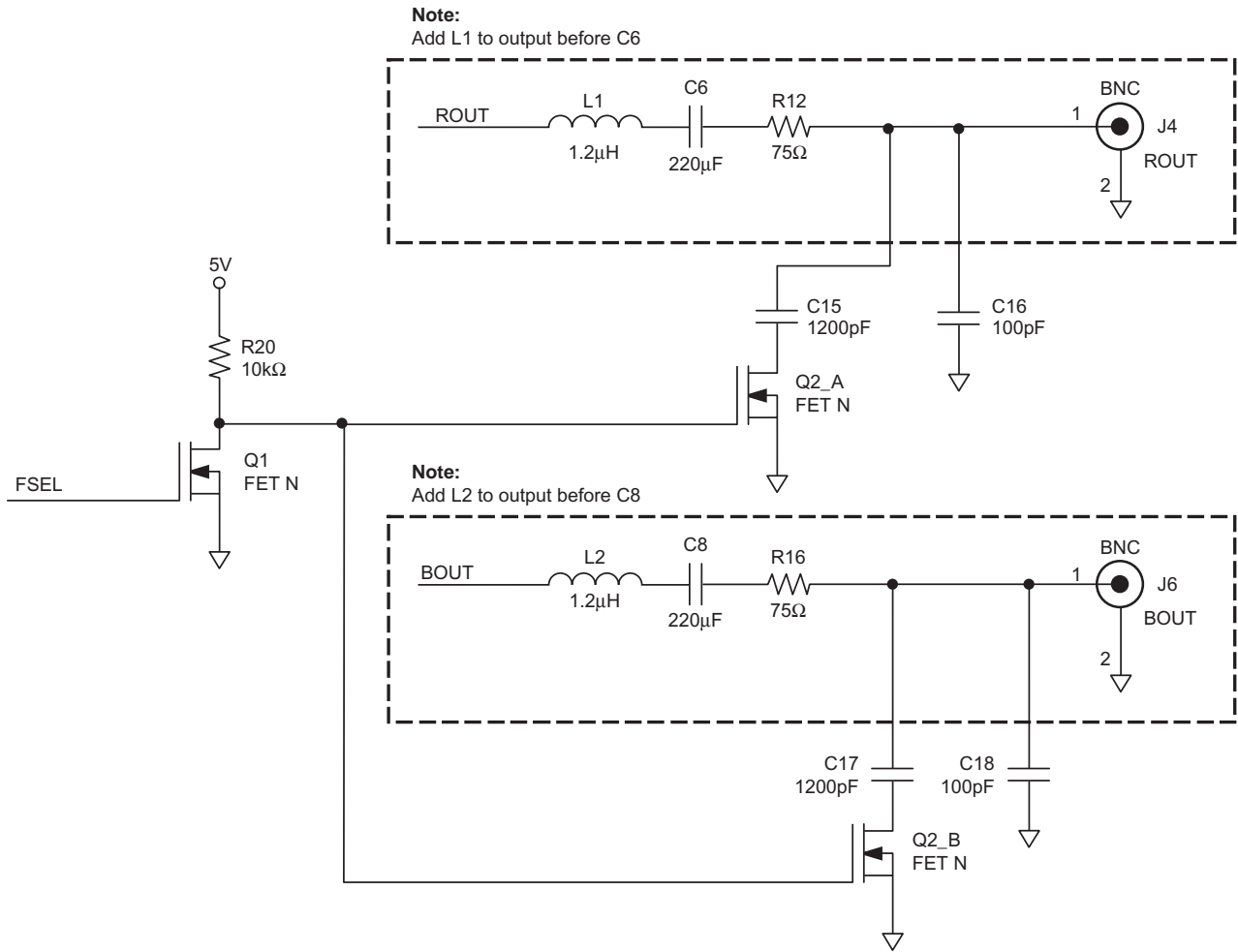

Figure 1. 4:2:2 Application Schematic

Capacitor Matrix

HD

	30MHz	15MHz	15MHz
C ₁₅	–	1200pf	–
C ₁₆	–	100pf	–
C ₁₇	–	–	1200pf
C ₁₈	–	–	100pf

SD

	8MHz	4MHz	4MHZ
C ₁₅	–	–	–
C ₁₆	–	100pf	–
C ₁₇	–	–	–
C ₁₈	–	–	100pf

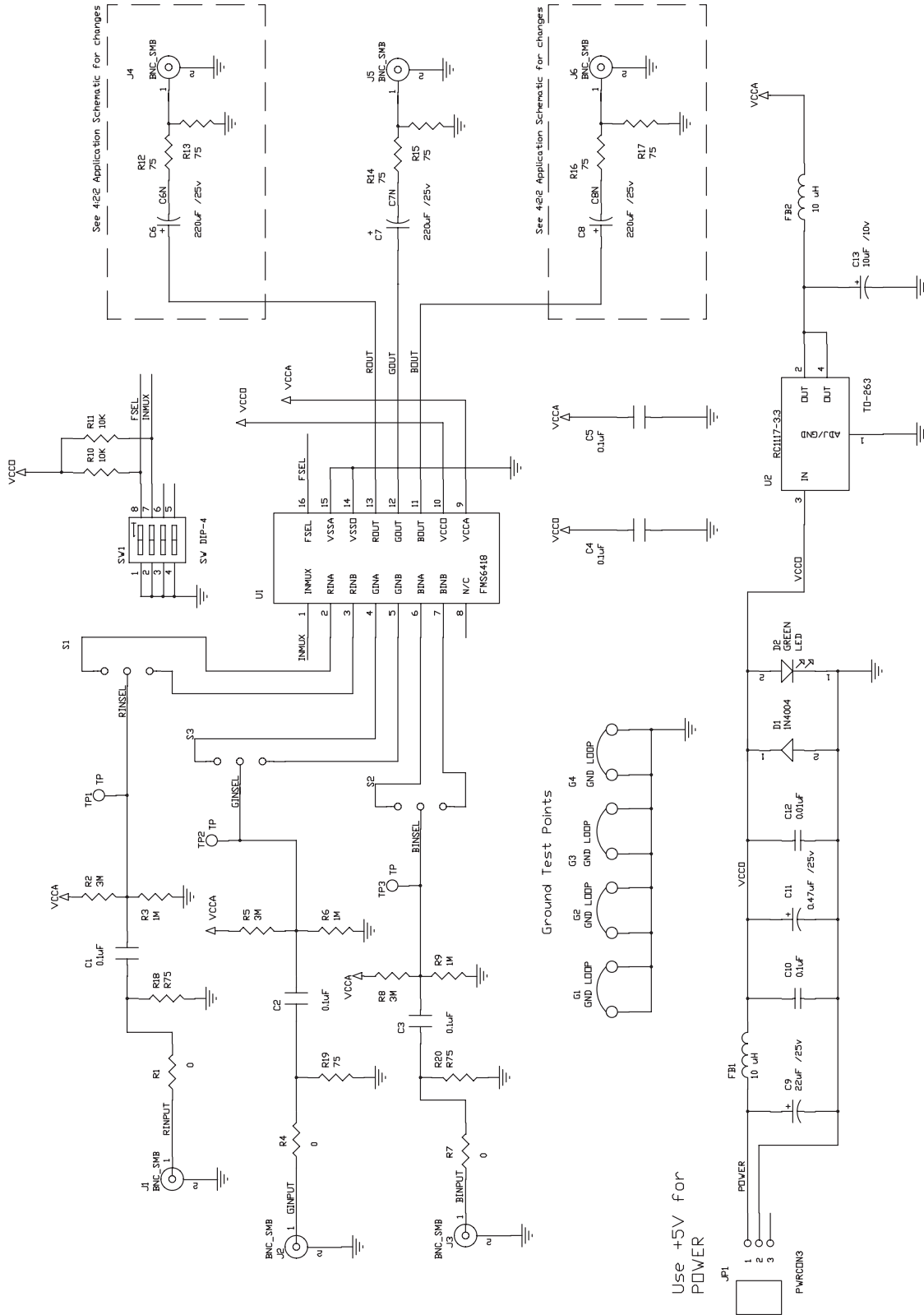

Figure 2. 4:2:2 Demo Board Schematic

FMS6418B Demo Bill of Materials

Item	Quantity	Reference	Part
1	6	C1, C2, C3, C4, C5, C10	0.1 μ F
2	3	C6, C7, C8	220 μ F/25V
3	1	C9	22 μ F/25V
4	1	C11	0.47 μ F/25V
5	1	C12	0.01 μ F
6	1	C13	10 μ F/10V
7	1	D1	1N4004
8	1	D2	GREEN
9	2	FB1, FB2	10 μ H
10	4	G1, G2, G3, G4	GND LOOP
11	1	JP1	PWRCON3
12	6	J1, J2, J3, J4, J5, J6	BNC_SMB
13	3	R1, R4, R7	0
14	3	R2, R5, R8	3M Ω
15	3	R3, R6, R9	681k Ω
16	3	R10, R11	10k Ω
17	9	R12, R13, R14, R15, R16, R17, R18, R19, R20	75 Ω
18	1	SW1	SW DIP-4
19	1	S1	RINSEL
20	1	S2	BINSEL
21	1	S3	GINSEL
22	3	TP1, TP2, TP3	TP
23	1	U1	FMS6418B
24	1	U2	RC1117-3.3

FMS6418B Modification (Bill of Materials)

Item	Quantity	Reference	Part
1	6	C1, C2, C3, C4, C5, C10	0.1 μ F
2	3	C6, C7, C8	220 μ F/25V
3	1	C9	22 μ F/25V
4	1	C11	0.47 μ F/25V
5	1	C12	0.01 μ F

DISCLAIMER

FAIRCHILD SEMICONDUCTOR RESERVES THE RIGHT TO MAKE CHANGES WITHOUT FURTHER NOTICE TO ANY PRODUCTS HEREIN TO IMPROVE RELIABILITY, FUNCTION, OR DESIGN. FAIRCHILD DOES NOT ASSUME ANY LIABILITY ARISING OUT OF THE APPLICATION OR USE OF ANY PRODUCT OR CIRCUIT DESCRIBED HEREIN; NEITHER DOES IT CONVEY ANY LICENSE UNDER ITS PATENT RIGHTS, NOR THE RIGHTS OF OTHERS.

LIFE SUPPORT POLICY

FAIRCHILD'S PRODUCTS ARE NOT AUTHORIZED FOR USE AS CRITICAL COMPONENTS IN LIFE SUPPORT DEVICES OR SYSTEMS WITHOUT THE EXPRESS WRITTEN APPROVAL OF THE PRESIDENT OF FAIRCHILD SEMICONDUCTOR CORPORATION. As used herein:

1. Life support devices or systems are devices or systems which, (a) are intended for surgical implant into the body, or (b) support or sustain life, or (c) whose failure to perform when properly used in accordance with instructions for use provided in the labeling, can be reasonably expected to result in significant injury to the user.

2. A critical component is any component of a life support device or system whose failure to perform can be reasonably expected to cause the failure of the life support device or system, or to affect its safety or effectiveness.