

AN-8017

FMS6151 Evaluation Board Application Note

Description

The FMS6151 Demonstration board provides a flexible base for evaluating the performance of the FMS6151. The board operates from a standard supply voltage of +2.7V to +5V \pm 5%.

The FMS6151 is a low cost, integrated, video filter that is intended to replace passive LC filters and drivers in 3V portable video applications. The device will operate in applications with a V_{CC} ranging from 2.7V to 5.5V. The 5th order filter provides better image quality compared to typical 2nd and 3rd order passive solutions.

Applications

- Digital Still Cameras
- Camera Phones
- Personal Digital Assistants
- Set Top boxes
- Personal Video Recorders
- Portable Media Players
- Portable DVD Players
- In Cabin Automotive Entertainment
- GPS Navigation Displays
- Security Monitoring

Reference Materials

- FMS6151 Data Sheet
- FMS6151 Application Note

Evaluation Board Block Diagram

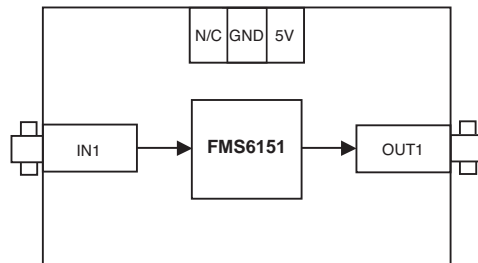

Evaluation Kit Contents

The FMS6151 Evaluation Kit contains the following items:

- AN-8017 – FMS6151 Evaluation Board Application Note
- The latest revision of the FMS6151 data sheet, which also can be obtained from <http://www.fairchildsemi.com>.
- Fully functional FMS6151 eval board
- Female power connector

Board Setup and Test

Use the following procedure to verify that the FMS6151 evaluation board is functional. This only verifies functionality. These instructions do not test any parameters outlined in the data sheet. The following test equipment is necessary to test the FMS6151 evaluation board.

- One power supply +5V \pm 5%, 50mA
- One SD monitor
- One SD video signal source capable of generating necessary outputs (Composite)
- One video measurement set (VM700)
- Assorted video cables

DO NOT turn on power supply until all connections are completed.

1. Set the power supply to 3.0V. Connect the power supply to the input voltage terminals of the evaluation board.
2. Connect the CV output of the signal source to the V_{IN} connector on the FMS6151 board.
3. Connect the V_{OUT} connector of the FMS6151 board to the CV input on the monitor.
4. Turn on the power supply.
5. Verify the SD monitor is setup correctly.
6. Verify the test pattern that is produced from the generator is the same as the pattern on the monitor screen.
7. Functional test is now complete.

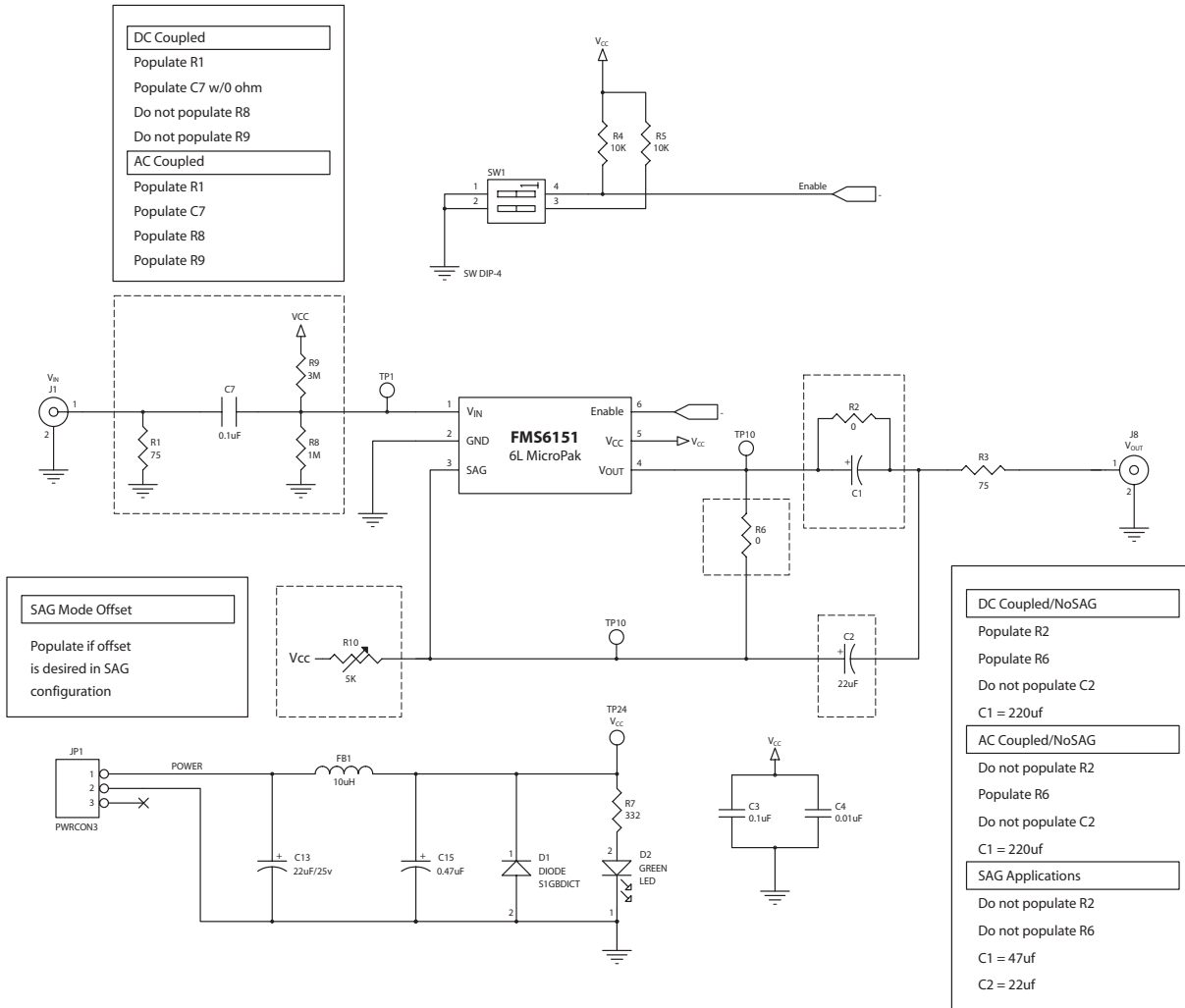

Figure 1. FMS6151 Schematic Diagram

Bill of Materials

Item	Quantity	Reference	Part
1	2	C1	220 μ F or 47 μ F
2	1	C2	22 μ F
3	2	C3, C7	0.1 μ F
4	1	C4	0.01 μ F
5	1	C13	22 μ F/25V
6	1	C15	0.47 μ F
7	1	D1	Diode
8	1	D2	GREEN
9	1	FB1	10 μ H
10	1	JP1	PWRCON3
11	1	J1	VIN
12	1	J8	VOUT
13	2	R1, R3	75
14	2	R2, R6	0
15	2	R4, R5	10k
16	1	R8	1M
17	1	R9	3M
18	1	SW1	SW DIP-4
19	1	TP1	VIN
20	1	TP10	VOUT
21	1	TP24	VCC
22	1	U1	6L MicroPak
23	1	5k	Resistor VAR

General Description

The FMS6151 is a low cost, integrated, video filter is intended to replace passive LC filters and drivers in 3V portable video applications. The device will operate in applications with a V_{cc} ranging from 2.5V to 5.5V. The 5th order filter provides better image quality compared to typical 2nd and 3rd order passive solutions. FMS6151 shutdown mode allows for reduced current, typically less than 25nA, dramatically reducing power consumption for prolonged battery life.

Applications

The FMS6151 is intended to be directly driven by a DC-coupled DAC output but can also operate with input AC-coupled. The output can drive AC or DC-coupled single 75Ω coax (150Ω) load. DC-coupling the output removes the need for expensive output coupling capacitors. If the output is AC-coupled, the SAG correction circuit can be used to reduce the value and the physical size of the AC output coupling capacitors and still product acceptable field tilt.

Offering SAG correction, fixed gain of 6dB and a 5th order low pass filter in a tiny space saving package (Micropak™) makes the FMS6151 well suited for space sensitive applications such as cellular phones and digital cameras.

Layout Considerations

General layout and supply bypassing play major roles in high frequency performance and thermal characteristics. The FMS6151DEMO is a 4-layer board with a full power and ground plane. For optimum results, follow the steps below as a basis for high frequency layout.

- Include 10 μ F and 0.1 μ F ceramic bypass capacitors
- Place the 10 μ F capacitor within 0.75 inches of the power pin
- Place the 0.1 μ F capacitor within 0.1 inches of the power pin
- Connect all external ground pins as tightly as possible, preferably with a large ground plane under the package
- Layout channel connections to reduce mutual trace inductance
- Minimize all trace lengths to reduce series inductances

If routing across a board, place device such that longer traces are at the inputs rather than the outputs.

DISCLAIMER

FAIRCHILD SEMICONDUCTOR RESERVES THE RIGHT TO MAKE CHANGES WITHOUT FURTHER NOTICE TO ANY PRODUCTS HEREIN TO IMPROVE RELIABILITY, FUNCTION OR DESIGN. FAIRCHILD DOES NOT ASSUME ANY LIABILITY ARISING OUT OF THE APPLICATION OR USE OF ANY PRODUCT OR CIRCUIT DESCRIBED HEREIN; NEITHER DOES IT CONVEY ANY LICENSE UNDER ITS PATENT RIGHTS, NOR THE RIGHTS OF OTHERS.

LIFE SUPPORT POLICY

FAIRCHILD'S PRODUCTS ARE NOT AUTHORIZED FOR USE AS CRITICAL COMPONENTS IN LIFE SUPPORT DEVICES OR SYSTEMS WITHOUT THE EXPRESS WRITTEN APPROVAL OF FAIRCHILD SEMICONDUCTOR CORPORATION. As used herein:

1. Life support devices or systems are devices or systems which, (a) are intended for surgical implant into the body, or (b) support or sustain life, or (c) whose failure to perform when properly used in accordance with instructions for use provided in the labeling, can be reasonably expected to result in significant injury to the user.
2. A critical component is any component of a life support device or system whose failure to perform can be reasonably expected to cause the failure of the life support device or system, or to affect its safety or effectiveness.