

AN-8025

Design Guideline of Single-Stage Flyback AC-DC Converter Using FAN7530 for LED Lighting

Summary

This application note describes the single-stage power factor correction (PFC) and presents the design guidelines of a 75W universal-input, single-stage PFC for LED lighting applications. Flyback converter topology controlled by the critical conduction mode control IC, FAN7530 is applied and several functions; such as CV/CC mode feedback circuits, cycle-by-cycle current limit, soft-starting function, and so on, are considered for LED lighting applications.

Introduction

Despite large output voltage ripple, single-stage AC-DC conversion is a more attractive solution than two-stage conversion from the standpoint of the cost and power density. Especially in applications like battery chargers, Plasma Display Panel (PDP)-sustaining power supplies, and LED lighting; low frequency, 100Hz or 120Hz, large output voltage ripple is inconsequential.

Single-stage AC-DC converter directly converts AC input voltage to the DC output voltage without a pre-regulator, as shown in Figure 1.

This application note presents a 75W single-stage AC-DC converter for LED lighting. As a power-conversion topology, flyback converter is normally chosen because it doesn't need an inductive output filter; the main transformer works as an inductive filter itself.

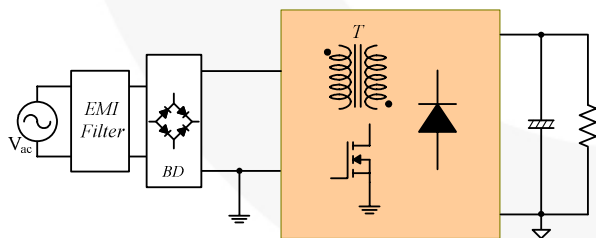

Figure 1. Single-Stage AC-DC Converter

Figure 2 shows the circuit diagram of a flyback AC-DC converter. FAN7530 is used as a controller and both CV (constant voltage) and CC (constant current) mode feedback circuits are applied to prevent overload and over-voltage conditions. In LED lighting, the output is always full-load condition and the forward voltage drop of LED decreases if the junction temperature of LED increases. Therefore the

output should be controlled by CC mode in the normal state while CV mode only works as over voltage protection.

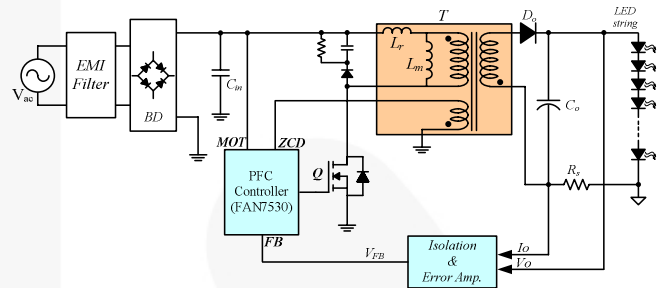

Figure 2. Flyback AC-DC Converter

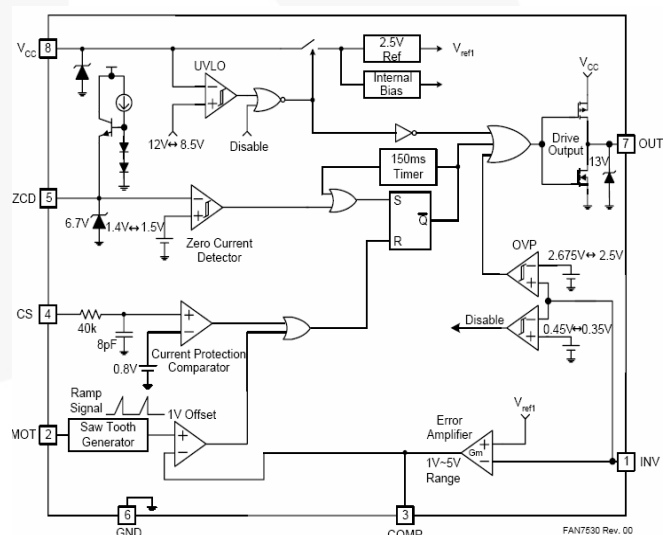

Figure 3. Block Diagram of FAN7530

Figure 3 shows the block diagram of FAN7530. Its major features are:

- Fixed On Time CRM PFC Controller
- Zero Current Detector (ZCS) & Valley Switching
- MOSFET Over-Current Protection
- Low Startup (40µA) and Operating Current (1.5mA)
- Totem Pole Output with High State Clamp
- +500/-800mA Peak Gate Drive Current

FAN7530 is a voltage-mode CRM PFC controller; the turn-on time of switch is fixed while the turn-off time is varied during the steady state. Therefore, the switching frequency varies in accordance with the input voltage variation shown in Figure 4.

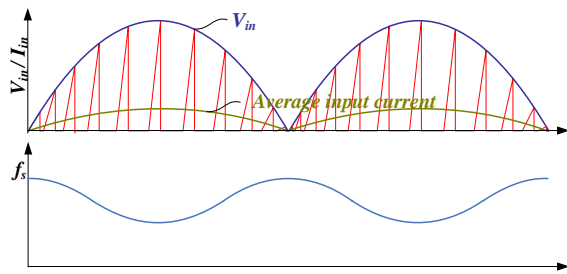

Figure 4. Switching Frequency Variation

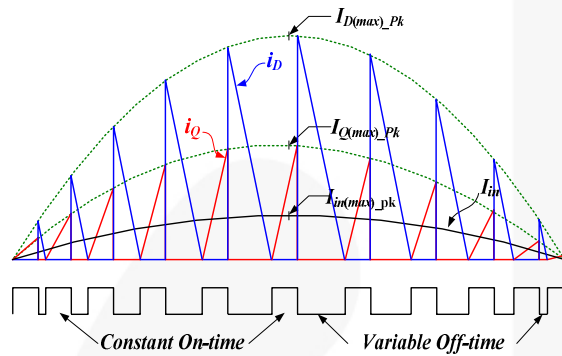

Figure 5. Theoretical Waveforms

Figure 5 illustrates the theoretical waveforms of the primary-side switch current, the secondary-side diode current, and gating signal. MOSFET Q turns on and Fast Recovery Diode (FRD) D_o turns off under zero-current condition, while Q turns off and D_o turns on under the hard-switching condition.

Design Example

A design guideline of 75W single-stage flyback AC-DC converter using FAN7530 is presented. The applied system parameters are shown in Table 1.

Table 1. System Parameters

Parameter	Value
Output Power	75W
Input Voltage Range	85~265V _{AC}
Output Voltage	45V
Output Limit Voltage	50V
Duty Ratio at $I_{in(max)_pk}$, $D_{@lin(max)_pk}$	0.6
Minimum Switching Frequency, $f_{s_min}@V_{in_min}$	50kHz
Efficiency, η	85%

1. Flyback Transformer Design

In flyback converter, the transformer is easily saturated because the transformer is only utilized in the first quadrant of B-H loop. Moreover, if it works under the critical conduction mode, the peak current is much higher than that of the continuous conduction mode. Therefore, air-gap should be inserted to prevent saturation of the transformer.

A proper turn ratio, N_1/N_2 , should also be considered in a

flyback single-stage AC-DC converter because the maximum voltage rating of the MOSFET and Fast Recover Diode (FRD) strongly relates to the turn ratio of transformer. There is a trade-off relationship between the drain-to-source voltage rating, V_{dss} , of MOSFET and the reverse voltage rating, V_R , of the FRD in accordance with the turn ratio of the transformer. A larger turn ratio (N_1/N_2) requires a higher V_R of FRD while V_{dss} of MOSFET is decreased. In contrast, a lower turn ratio causes a higher voltage stress on the MOSFET, while V_R of the FRD is decreased. Figure 6 shows the trade-off relationship between V_{dss} of the MOSFET and V_R of the FRD.

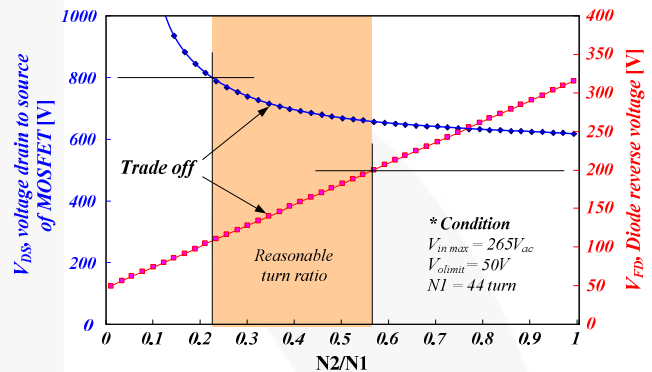

Figure 6. Trade-Off Between V_{DS} and V_R

From $P_o = \eta V_{in} I_{in}$, the maximum line current $I_{in(max)} = P_o / \eta V_{in(min)}$. If switching frequency f_s is much higher than the AC line frequency, f_{ac} , the input current can be assumed to be constant during one switching period.

To define the magnetizing inductance of transformer, the largest period must be defined. The largest switching period occurs at the peak of input current, $I_{in(max)_pk}$, when the minimum input voltage is applied. It can be defined as:

$$I_{in(max)_pk} = \frac{1}{T} \int_0^{DT} \frac{I_{Q(max)_pk}}{DT} t dt = \frac{DI_{Q(max)_pk}}{2} \quad (1)$$

$$I_{Q(max)_pk} = \frac{2}{D} I_{in(max)_pk} \quad (2)$$

where $D = D_{@lin(max)_pk}$, $I_{in(max)_pk} = \sqrt{2} I_{in(max)}$, and $V_{in(min)_pk} = \sqrt{2} V_{in(min)}$, respectively.

The transformer primary-side voltage, V_T , is defined as:

$$V_T = L_m \frac{\Delta I}{\Delta T} = L_m \frac{I_{Q(max)_pk} f_{s(min)}}{D_{@lin(max)_pk}} \quad (3)$$

Therefore, the magnetizing inductance is calculated by:

$$L_m \geq \frac{D_{@lin(max)_pk}^2 \cdot V_{in(min)}}{2 I_{in(max)} f_{s(min)}} = \frac{0.6^2 \times 85}{2 \times 1.04 \times 50 \times 10^3} \quad (4)$$

$$= 294.8 \mu H$$

From Equation (4) and Table 1, the calculated magnetizing inductance is 294 μ H.

There are several methods defining the turn number for the desirable inductance, but using the AL-value is the most

common and the easiest. The turn number can be obtained with AL-value as:

$$N = \sqrt{\frac{L}{AL\text{-value}}} \quad (5)$$

However, if air-gap is inserted into the magnetic core, a designer should find the AL-value. To obtain AL-value, wind several turns into a bobbin and measure the inductance, then calculate AL-value with the equation:

$$AL\text{-value} = \frac{L}{N^2} \quad (6)$$

Once the AL-value is obtained, calculate the turn number using Equation (6).

Applying coil dummy EER3435 with 0.33mm of air gap for the transformer and 14.9μH is measured when 10 turns are wound into the core and 0.149×10⁻⁶ of AL-value is obtained. Therefore, the calculated primary-side turn number is 44.5 from Equation (6) and finally determines 44 as the primary-side turn number. (The actual inductance is measured as 330μH.)

The secondary-side turn number is obtained as 17 turns by following equation:

$$N_2 = \frac{\pi N_1 V_o (1 - D_{\max})}{2\sqrt{2} D_{\max} V_{in(\min)}} = \frac{\pi \times 44 \times 45 (1 - 0.6)}{2\sqrt{2} \times 0.6 \times 85} = 17 \quad (7)$$

2. MOSFET and FRD

The voltage stress of MOSFET is calculated as:

$$\begin{aligned} V_{ds(\max)} &= V_{in(\max)_pk} + V_{sn(\max)} \\ &= V_{in(\max)_pk} + V_f + V_{Lk} \end{aligned} \quad (8)$$

where V_{sn} is the maximum capacitor voltage of the snubber circuit; V_f is the flyback voltage; and V_{Lk} is the ringing voltage at the leakage inductance of the transformer. V_f is derived by $N_1 V_o / N_2$ and V_{Lk} is normally estimated as 1.5 times the flyback voltage, V_f . Therefore, the maximum voltage of MOSFET is obtained as:

$$\begin{aligned} V_{ds(\max)} &= \sqrt{2} V_{in(\max)} + 2.5 n V_o = \sqrt{2} \times 265 \times 2.5 + \frac{44}{17} \times 45 \\ &= 665.94V \end{aligned} \quad (9)$$

The maximum rms current and the peak current are:

$$I_{in(\max)} = \frac{P_o}{\eta V_{in(\min)}} = \frac{75}{0.85 \times 85} = 1.04A \quad (10)$$

and

$$I_{Q(\max)_pk} = \frac{2\sqrt{2} P_o}{\eta D_{@lin(\max)_pk} V_{in(\min)}} = \frac{2\sqrt{2} \times 75}{0.85 \times 0.6 \times 85} = 4.89A \quad (11)$$

respectively.

Therefore, an N-Channel enhancement-mode MOSFET, FQP8N80C (800V, 8A, $R_{DS_ON} = 1.55\Omega$), is chosen in consideration of the margins.

The maximum reverse voltage and the forward peak current of the FRD are:

$$\begin{aligned} V_{R(\max)} &= V_{o_Limit} + \frac{N_2}{N_1} V_{in(\max)_pk} \\ &= 50 + \frac{17}{44} \times \sqrt{2} \times 265 = 195V \end{aligned} \quad (12)$$

$$I_{R_pk} = \frac{2}{(1 - D_{@lin(\max)_pk})} I_o = \frac{2}{(1 - 0.6)} \times \frac{75}{45} = 8.33A \quad (13)$$

respectively. Therefore, the Ultra-Fast Rectifier Diode (UFRD), F06UP20S (200V, 6A, $V_F = 1.15V$), is finally chosen in consideration of the margins.

3. Snubber Circuit Design

In flyback converter, the resonant between L_{leak} and C_{oss} causes an excessively high voltage surge that causes damage to the MOSFET during turn-off. This voltage surge must be suppressed and a snubber circuit is therefore necessary to prevent MOSFET failures.

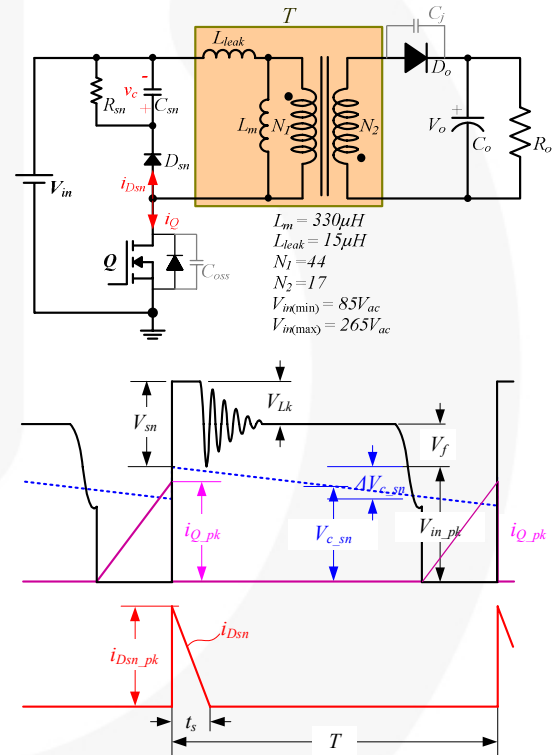

Figure 7. Snubber Circuit

The clamping voltage by snubber is:

$$V_{sn} = V_f + L_{leak} \frac{\Delta i}{\Delta t} = V_f + L_{leak} \frac{I_{Dsn_pk}}{t_s} \quad (14)$$

Therefore:

$$t_s = \frac{L_{leak} \cdot I_{Dsn_pk}}{V_{sn} - V_f} \quad (15)$$

The maximum power dissipation of the snubber circuit is determined by:

$$P_{sn} = \frac{1}{T} \int_0^{t_s} V_{sn} \cdot \frac{I_{Dsn_pk}}{t_s} t dt = \frac{1}{2} L_{leak} I_{Dsn_pk}^2 \frac{V_{sn}}{V_{sn} - V_f} f_s \quad (16)$$

The maximum power dissipation is:

$$P_{sn(max)} = \frac{1}{2} L_{leak} I_{Dsn_pk}^2 \frac{V_{sn}}{V_{sn} - V_f} f_{s@v_{in_max}} = \frac{V_{sn}^2}{R_{sn}} \quad (17)$$

where $V_{sn} = V_f + V_{Lr}$

Therefore, the resistance, R_{sn} , is determined by:

$$R_{sn} = \frac{V_{sn}^2}{\frac{1}{2} L_{leak} I_{Dsn_pk}^2 \frac{V_{sn}}{V_{sn} - V_f} f_{s@v_{in_max}}} \quad (18)$$

The maximum ripple voltage of the snubber circuit is obtained by:

$$\Delta V_{sn} = \frac{V_{sn}}{C_{sn} R_{sn} f_{s@v_{in_max}}} \quad (19)$$

The larger snubber capacitor results, the lower voltage ripple, but the power dissipation increases. Consequently, selecting the proper value is important. In general, it is reasonable to determine that the surge voltage of snubber circuit, V_{sn} , is two to three (2~3) times the flyback voltage, V_f , and the ripple voltage, Δv_c , is 50V. In this application note, the snubber voltage is 2.5 times of the flyback voltage. Thus, the snubber resistor and capacitor are determined by the following equations:

$$I_{Dsn_pk@V_{in}=265V} = \frac{2\sqrt{2}P_o}{\eta D_{min} V_{in}} = \frac{2\sqrt{2} \times 75}{0.85 \times 0.33 \times 265} = 2.85A \quad (20)$$

$$V_{sn} = V_f + V_{Lr} = 2.5V_f = 2.5 \times \frac{44}{17} \times 45 = 291.17V \quad (21)$$

$$t_s = \frac{L_{leak} \cdot I_{Dsn_pk}}{V_{sn} - V_f} = \frac{15 \times 10^{-6} \times 2.85}{291.17 - \frac{44}{17} \times 45} = 245.03nsec \quad (22)$$

$$f_{s@v_{in_max}} = \frac{D_{min} V_{sn}}{L_m(measured) I_{Dsn_pk@V_{in}=265V}} = \frac{0.33 \times 291.17}{330 \times 10^{-6} \times 2.85} = 102.03kHz \quad (23)$$

$$R_{sn} = \frac{1}{\frac{1}{2} \times 15\mu \times 2.85^2 \times \frac{291.17}{291.17 - (\frac{44}{17})45} \times 102.03k} = 8.16k\Omega \quad (24)$$

$$C_{sn} = \frac{V_{sn}}{\Delta V_{sn} R_{sn} f_{s@v_{in_max}}} = \frac{291.17}{50 \times 8.16k \times 102.03k} = 6.99nF \quad (25)$$

where the minimum duty ratio is obtained as:

$$D_{min} = \frac{V_o}{\frac{N_2}{N_1} V_{avg(max)} + V_o} = \frac{45}{\frac{17}{44} \times \left(\frac{2\sqrt{2}}{\pi} \times 265 \right) + 45} = 0.33 \quad (26)$$

Even though the calculated R_{sn} is 8.16k Ω , the actual resistance value should be increased because large power dissipation in the snubber circuit is expected due to small resistance. In practice, it is reasonable to choose the resistance about two times of the calculated value.

4. Sensing Resistor

The CS pin of FAN7530 limits the peak current and protects the MOSFET during transient state or over load condition. Normally, it is reasonable to limit to 1.5 times the switching peak current. The limiting level of switching peak current and the sensing resistor are obtained as:

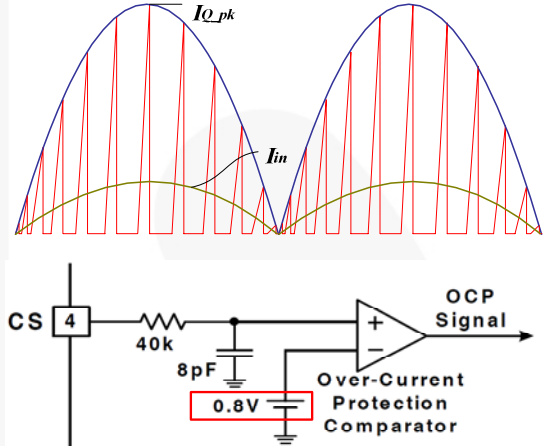

Figure 8. Switching Current Limit

$$I_{Q_Limit} = 1.5 I_{Q(max)_pk} = 1.5 \times \frac{2}{D_{max}} \left(\sqrt{2} \frac{P_o}{\eta V_{in(min)}} \right) \quad (27)$$

$$= 1.5 \times \frac{2}{0.6} \left(\sqrt{2} \frac{75}{0.85 \times 85} \right) = 7.4A$$

$$R_s \leq \frac{0.8}{I_{Q_Limit}} = \frac{0.8}{7.4} = 0.11\Omega \quad (28)$$

5. Soft-starting Circuit

Since the FAN7530 is designed for a non-isolated boost PFC circuit, some circuits are added externally. The internal disable amplifier can be used as soft-start function when FAN7530 is applied to non-isolated PFC circuit. However, the disable amplifier cannot participate in the operation if it is applied to isolated single stage PFC circuit because the initial voltage at Pin 1 is zero and FAN7530 cannot start. To exclude the disable amplifier from operation, over 0.5V of voltage must be applied through a blocking diode, as shown in Figure 9(a).

The initial V_{FB} is approximately defined as:

$$V_{FB_initial} = \frac{R_1 R_{FB}}{R_{FB}(R_1 + R_2) + R_1 R_2} \cdot VCC \quad (29)$$

To prevent MOSFET failure due to the initial excessive switching current, an external soft-start function is necessary. The circuit shown in Figure 9(b) makes the output voltage of E/A increase slowly and, consequently,

the converter can be smoothly started in accordance with the gradual increase of the on time.

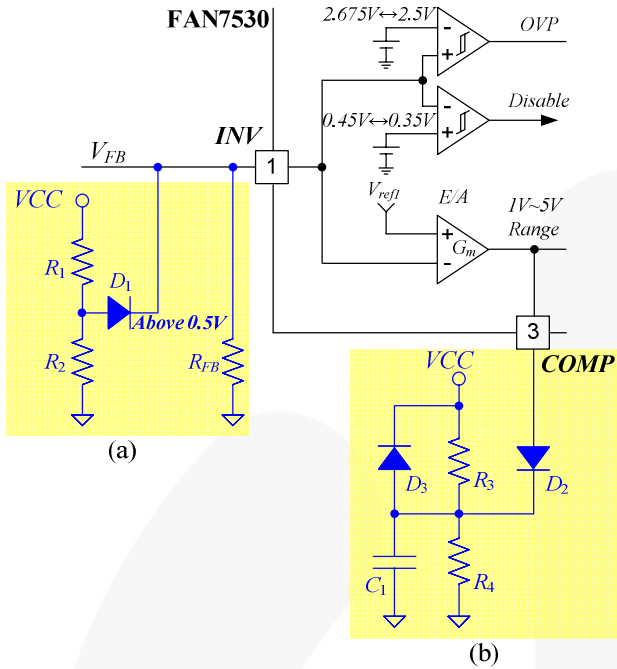

Figure 9. Soft-Starting Circuit

6. Voltage and Current Feedback

Power supplies for LED lighting must be controlled by constant current (CC) mode as well as a constant voltage (CV) mode. Because the forward voltage drop of LED varies with the junction temperature and the current also increases greatly consequently, devices can be damaged.

Figure 10 shows an example of a CC and CV mode feedback circuit. During normal operation, CC mode is dominant and CV mode only acts as OVP for abnormal modes.

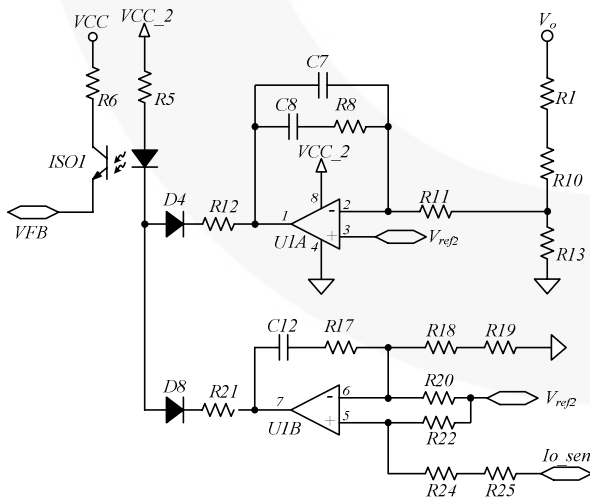

Figure 10. Example of CC & CV Feedback Circuit

Experimental Results

To verify the validity of the design guideline in this application note, a prototype test set-up was built and tested. The design parameter and component values are shown in the appendix.

Figure 11 shows the input voltage and current at 110V_{AC} input and 220V_{AC} input conditions. The power factors at 110V_{AC} and 220V_{AC} condition are measured as 0.997 and 0.955, respectively.

Figure 12 shows the waveforms of the switching voltage and current, which shows the switching current waveforms following the shape of the input voltage well. The switch is turned on at zero current condition.

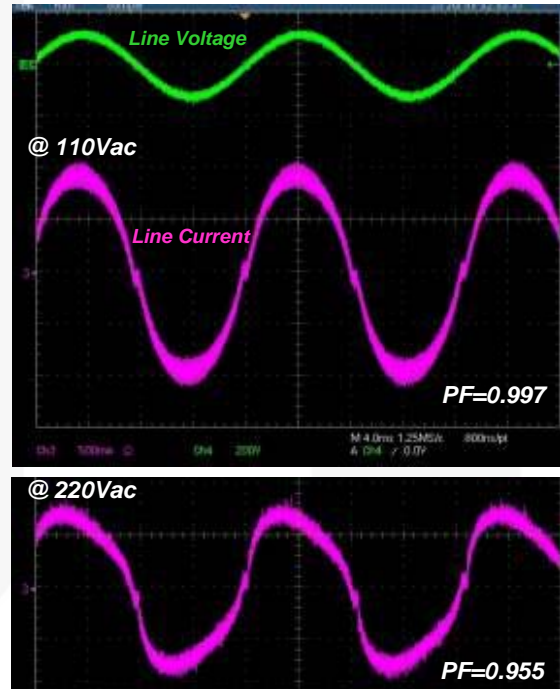
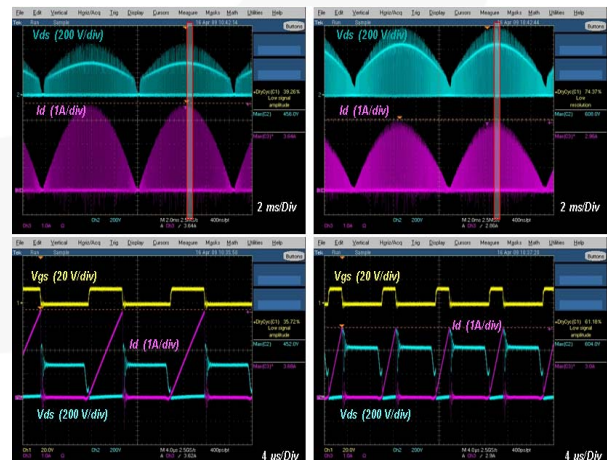

Figure 11. Input Voltage and Current



(a) at 110 V_{ac} Input (b) at 220 V_{ac} Input
Figure 12. Switching Voltage and Current

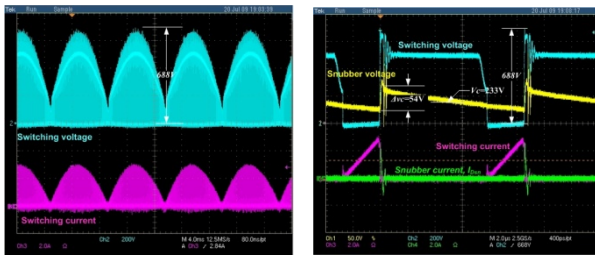

Figure 13. Drain-Source Voltage and Switching Current at 265V_{AC} Input Condition

Figure 13 shows the waveforms of the drain-source voltage and current of 265V of input line voltage, the maximum input voltage, is applied. The voltage ripple of snubber circuit is measured at 54V and the maximum voltage stress is 688V. Since the maximum voltage is 688V, 800V rating MOSFET is needed for wide input voltage range.

The efficiency characteristics according to the load variation for 110 V_{ac} and 220 V_{ac} of the input conditions are plotted in Figure 14. In the case of 110V_{ac} input, the maximum efficiency is measured as 85.17% at 45W load condition.

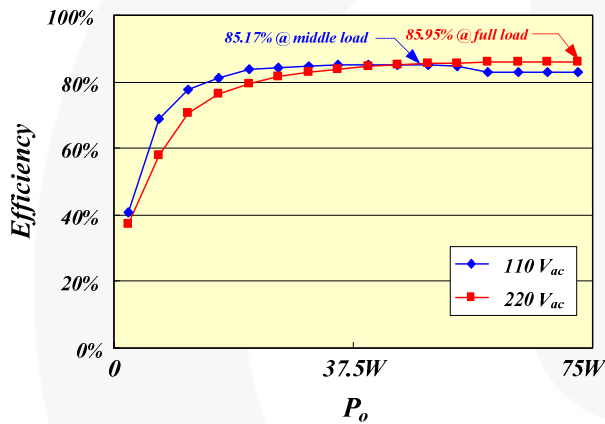

Figure 14. Efficiency Comparison

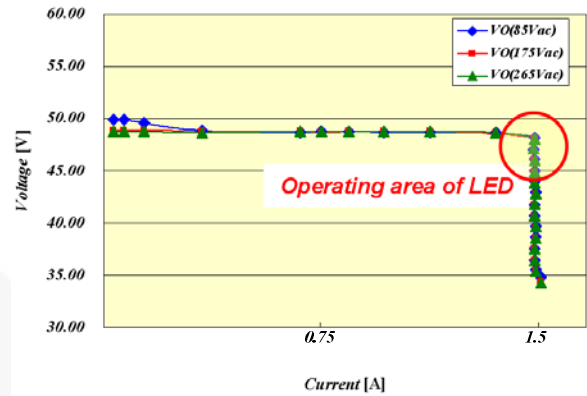

Figure 15. Output V-I Characteristic

In the case of 220V_{ac} input, the maximum efficiency is measured as 85.95% at full-load condition 75W.

In LED lighting, LED strings are driven by the rating current and the power supply should be operated under the full-load condition. Therefore, the power supply is controlled by constant current during normal condition. Figure 15 shows the V-I characteristics of the prototype experimental set-up. The result verifies that the output is driven well by the constant current control for whole input voltage condition.

Schematic

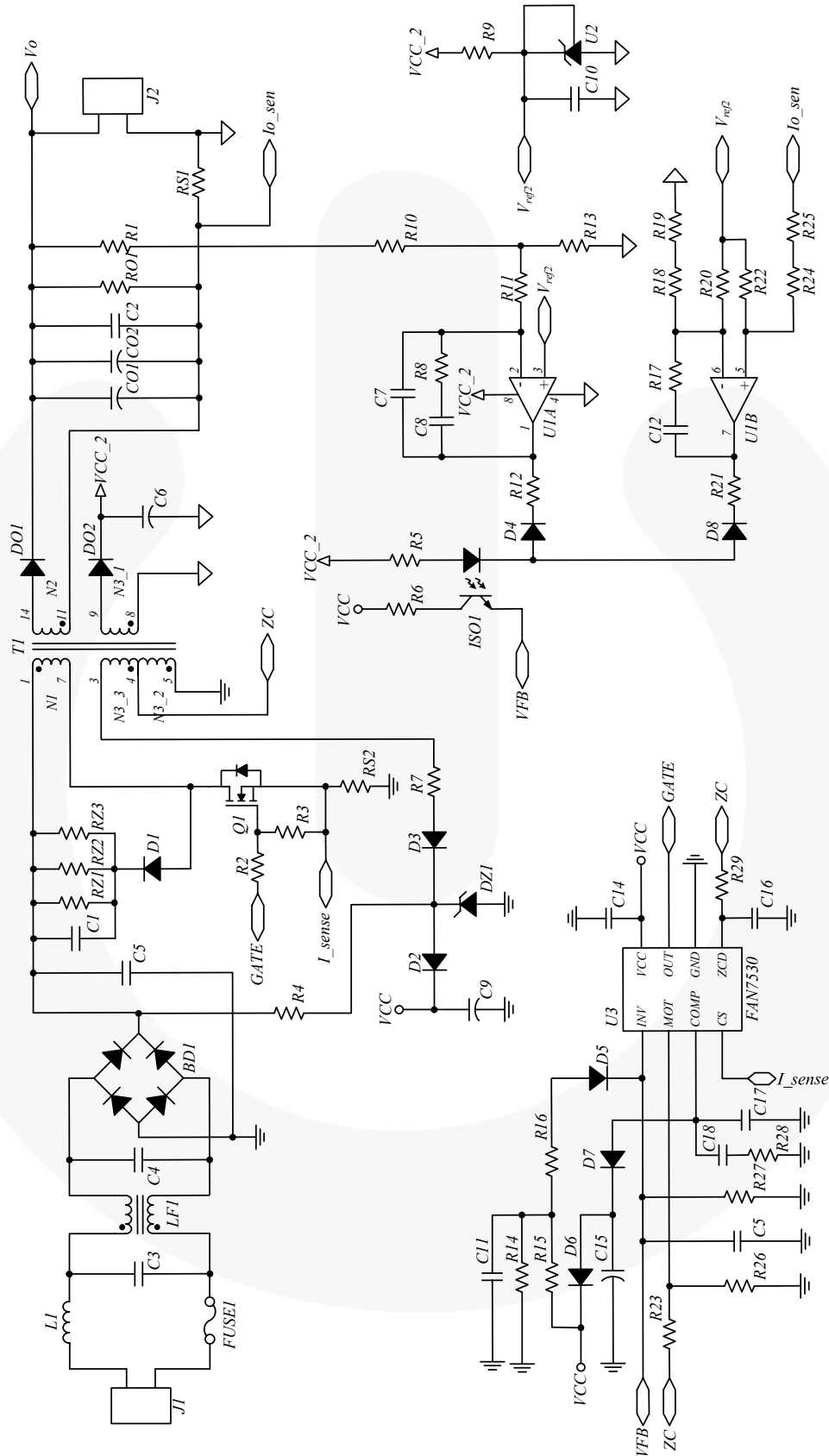

Figure 16. Schematic

Part List

Component	Symbol	Value/Part Number	Component	Symbol	Value/Part Number
Rectifier	BD1	GBU8J		R1	49.9k Ω
Capacitor	C1	472/1kV	Resistor	R2	15 Ω
	C2	104		R3	1.5k Ω
	C3	220nF		R4	56k Ω /2Watt
	C4	440nF		R5	3.3k Ω
	C5	474/NP/630V		R6	11k Ω
	C6	33 μ /35V		R7	1.5/1W
	C7	473		R8	100k Ω
	C8	224		R9	1.2k Ω
	C9	33 μ /35V		R10	47k Ω
	C10	100p		R11	50k Ω
	C11	224		R12	11k Ω
	C12	155		R13	5.1k Ω
	C13	106		R14	1.2k Ω
	C14	105		R15	10k Ω
	C15	683		R16	33 Ω
	C16	56p		R17	10k Ω
	C17	473		R18	2k Ω
	C18	224		R19	10 Ω
	C19	105		R20	2k Ω
	CO1	2200 μ /63V		R21	8.2k Ω
CO2	2200 μ /63V	R22	2k Ω		
Diode	D1	UF4005	R23	330k Ω	
	D2	RGF1J	R24	2.1k Ω	
	D3	UF4005	R25	33 Ω	
	D4	1N4148	R26	30k Ω	
	D5	1N4148	R27	5.1k Ω	
	D6	1N4148	R28	100k Ω	
	D7	1N4148	R29	47k Ω	
	D8	1N4148	RO1	56k Ω /2Watt	
	DO1	F06UP20S	RS1	0.05 Ω /5Watt	
	DO2	UF4005	RS2	0.1 Ω /5Watt	
Zener diode	DZ1	1N4746(18V)	RZ1	56k Ω /2Watt	
Fuse	FUSE1	FUSE	RZ2	56k Ω /2Watt	
Opto-coupler	ISO1	PC817	RZ3	56k Ω /2Watt	
Connector	J1	CON4	Transformer	T1	EER3435
	J2	CON4	Op-Amp.	U1A,B	KA358
Inductor	L1	330 μ H	Regulator	U2	KA431
Chock-coil	LF1	EMI_CHOCK	PFC IC	U3	FAN7530
MOSFET	Q1	FQPF8N80C			

Related Datasheets

[FAN7527 — Boundary Mode PFC Control IC](#)

[FAN7528 — Dual-Output Critical Conduction Mode PFC Controller](#)

[FAN7529 — Critical Conduction Mode PFC Controller](#)

[FAN7530 — Critical Conduction Mode PFC Controller](#)

Author

by Jae-Eul Yeon/Ph. D.

HV-PCIA/Fairchild Korea Semiconductor

+82-32-680-1935

E-mail : jaeul.yeon@fairchildsemi.com

DISCLAIMER

FAIRCHILD SEMICONDUCTOR RESERVES THE RIGHT TO MAKE CHANGES WITHOUT FURTHER NOTICE TO ANY PRODUCTS HEREIN TO IMPROVE RELIABILITY, FUNCTION, OR DESIGN. FAIRCHILD DOES NOT ASSUME ANY LIABILITY ARISING OUT OF THE APPLICATION OR USE OF ANY PRODUCT OR CIRCUIT DESCRIBED HEREIN; NEITHER DOES IT CONVEY ANY LICENSE UNDER ITS PATENT RIGHTS, NOR THE RIGHTS OF OTHERS.

LIFE SUPPORT POLICY

FAIRCHILD'S PRODUCTS ARE NOT AUTHORIZED FOR USE AS CRITICAL COMPONENTS IN LIFE SUPPORT DEVICES OR SYSTEMS WITHOUT THE EXPRESS WRITTEN APPROVAL OF THE PRESIDENT OF FAIRCHILD SEMICONDUCTOR CORPORATION.

As used herein:

1. Life support devices or systems are devices or systems which, (a) are intended for surgical implant into the body, or (b) support or sustain life, or (c) whose failure to perform when properly used in accordance with instructions for use provided in the labeling, can be reasonably expected to result in significant injury to the user.
2. A critical component is any component of a life support device or system whose failure to perform can be reasonably expected to cause the failure of the life support device or system, or to affect its safety or effectiveness.