

Characteristics and Measurement Techniques of the Spectral Content of Signals Generated by High-Performance ICs

INTRODUCTION

Electromagnetic Interference (EMI) has long been an issue in the integrity and certification of electronic systems. Until recently design and measurement of electromagnetic compatibility (EMC) has predominantly been the focus of the back end of electronic systems manufacturing. Before a finished product could be sold on the U.S. market, the system had to be certified compliant to FCC Rules and Regulations, Part 15 emissions limitations. Should a system fail to comply, the responsibility of correction also usually fell upon the back-end manufacturing engineers.

*Electromagnetic compatibility (EMC) is the ability of systems, subsystems, circuits, and components to function as designed, without malfunction or unacceptable performance degradation due to EMI, within their intended operational environment.*¹ As more high-speed/high-frequency systems are developed and brought to market, emission-regulating agencies are challenged to develop stricter limits and more accurate test methodologies. Similarly, system design, manufacturing, and quality assurance engineers are challenged to develop higher performance systems, simultaneously developing more advanced EMC design techniques and in-house measurement and control methods.

EMI—AN OVERVIEW

*Electromagnetic interference consists of any unwanted spurious, conducted, and/or radiated signal(s) of electrical origin that can cause unacceptable degradation of system or equipment performance.*¹ Whenever an electric charge is accelerated, electromagnetic waves are generated. This energy can create interference that may result in erroneous transmission of data, lost data, or a reduction in the amount of acceptable noise for that system. EMI can occur from one electronic system to another (most commonplace) or within the same system, from one section of the system to another.

The most common medium for interference is free air, i.e., radiated interference. In the early days of electricity, free air, once called the ether, was thought to be an invisible ohmic medium across which all electrical interaction took place. Today, free air is considered a dielectric medium across which electric and magnetic fields and waves interact.

Original equipment manufacturers (OEMs) can regulate the interference level within their own system, but they

have no control over the emissions of another OEM's system. Providing this control falls to governmental agencies which develop, maintain, and enforce maximum levels of electromagnetic interference in free air. In the United States, this regulatory agency is the Federal Communications Commission (FCC). In Europe and Asia, emission regulations are set and enforced by a committee within each government's postal agencies. In most of Europe, for example, individual postal agencies set compliance limits based on those developed by an international committee, the Comite Special International des Perturbations Radio-electriques (CISPR). In Germany, emissions standards are regulated by the Verband Deutscher Elektrotechniker (VDE), or Association of German Electrical Engineers. Beginning in January 1996 all European Community countries will regulate EMC based on EEC Directive 89/336/EEC.

EMI GENERATION

EMI in an electronic system may result from several sources. All mediums of electronic signal transmission—from the signal's origin to its destination—are possible sources of, or antennae for, radiated EMI. Understanding how each medium—from semiconductors to coaxial cables to connectors and more—radiate EMI is important for effective, high-performance computer design. To optimize performance, design measures that minimize radiated EMI begin at the IC level and continue to the design of the enclosure and any interconnecting cables.

Typical electric and magnetic fields in electronic circuits are generated by current pulses propagating along a path or a loop within the circuit. Each current pulse that propagates along the path creates a magnetic field perpendicular to the plane of the current path. The resulting voltage drop along the path creates an electric field opposite to the propagation direction and within the same current plane. Most common current paths within a personal computer consist of I/O cables, printed circuit board (PCB) signal traces, power supply cables, and power-to-ground loops. These paths act as antennae, radiating electric and magnetic fields. Interaction of these fields with other signals is EMI.

The magnitude of EMI generation is a function of several characteristics of the transmitted signal, such as its frequency, duty cycle, edge rate, and voltage swing (amplitude). Determining the role of transmitted signal characteristics is best analyzed in the frequency domain using a Fourier transformation.

FOURIER ANALYSIS

Interpreting Fourier's Theorem, any periodic function in the time domain, $f(t)$, may be represented by an infinite series of sines and cosines:

$$f(t) = A_0 + A_1 \cos(\omega t) + A_2 \cos(2\omega t) + \dots + A_n \cos(n\omega t) + B_1 \sin(\omega t) + B_2 \sin(2\omega t) + \dots + B_n \sin(n\omega t)$$

where $\omega = 2\pi/T$ and $T = 1/\text{frequency}$. Figure 1 illustrates an arbitrary square wave function, $f(t)$, and the first seven calculated harmonics. In this example the term A_0 equals the average DC bias voltage (2.5V); the terms A_x are zero when x is an even number, from x equals 2 to n ; and the terms B_x are zero for all x , from x equals 1 to n . As the value of n is increased (i.e., the addition of more harmonics into the equation), the original square wave is more accurately reconstructed. Figure 2 illustrates reconstruction of the square wave using up to 27 harmonics.

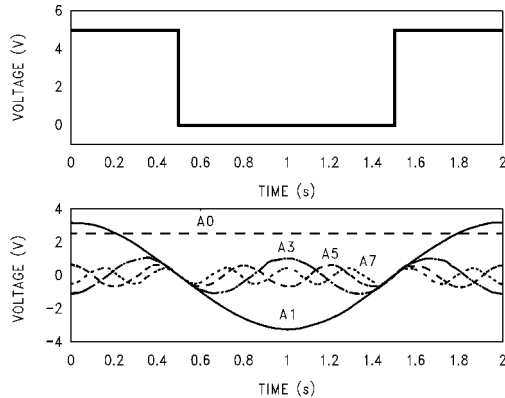

FIGURE 1. Square Wave with First Seven Harmonics

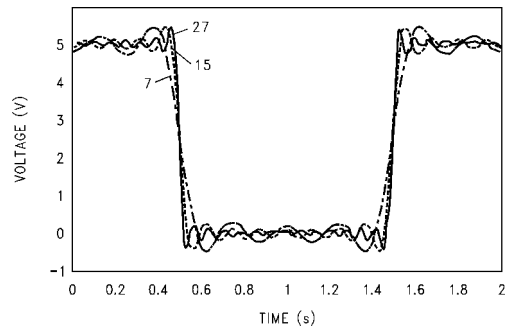
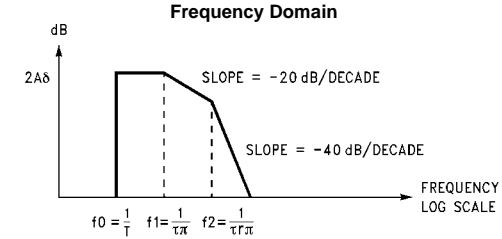
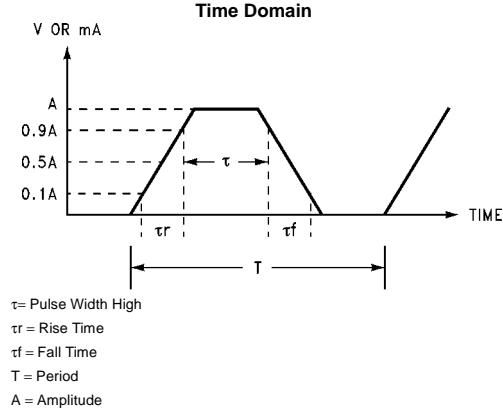

FIGURE 2. Reconstruction Using 7, 15, 27 Harmonics

Another method to predict frequency, or spectral, content based on a signal's time-domain characteristics is known as the *worst-case upper-bound approximation*. Figure 3 illustrates the approximation of the spectral content of a periodic trapezoidal pulse train. This periodic pulse train represents a digital logic pulse train. Key characteristics of the frequency-domain signal are the amplitude and the points at which the slope of the signal's amplitude changes with increasing frequency.

The first point on the frequency-domain signal, f_0 , is the *fundamental frequency*. The fundamental frequency is the inverse of the signal's time-domain period. The amplitude of the predicted emission is usually greatest at the fundamental frequency. Each frequency component within the

remaining portion of the envelope occurs at harmonics of the fundamental frequency.



τ = Pulse Width High
 τ_r = Rise Time
 τ_f = Fall Time
 T = Period
 A = Amplitude

FIGURE 3. Worst-Case Upper-Bound Approximation

The second point on the frequency-domain approximation and the first *break point*, f_1 , is inversely proportional to the pulse width HIGH of the time-domain signal by a factor of pi. At this point, the amplitude of possible emissions begins to drop at a rate of 20 dB per decade (plotted on a semi-logarithmic scale). Note that for a 50% duty cycle periodic function, f_0 and f_1 are one and the same point.

The third point, and the second *break point*, f_2 , is inversely proportional to the rise or fall time of the time-domain signal (whichever is smaller), also by a factor of pi. At this point the amplitude of the emissions begins to drop at 40 dB per decade until the amplitude reaches zero dB.

By decreasing the duty cycle and/or the rise time of the time-domain signal, the bandwidth of possible emissions increases. Since the wavelength of a signal is the speed of light divided by frequency, the higher the frequency content, the smaller the resulting wavelengths.

MEASURING THE SPECTRAL CONTENT OF A LOGIC IC

In order to analyze the frequency, or spectral content of logic ICs, two measurement techniques have been developed. One method, *The Radiated Measurement Method*, is based on the system-level FCC certification test methodology, FCC Open Site Test (OST) 55. The radiated method utilizes a multilayer PCB with the IC-under-test is mounted on a grounded, adjustable table placed 3 meters from an antenna mast (see Figure 4). The IC's input is stimulated

by a known periodic waveform and its output drives a typical PCB microstrip. The 75Ω microstrip is properly terminated to prevent reflections from affecting the IC's spectral content results.

The FCC certification test method is an *open field* measurement procedure. Therefore, the spectral content of the device-under-test (in this case, an IC) cannot be detected below the ambient level of radiation. The test-site is permanent and the average ambient noise level remains relatively constant.

The detectable spectral content of the IC-under-test is then analyzed and displayed by a spectral analyzer. Figure 5 is a typical spectral content measurement plot. At first glance the result is not one that may have been predicted by the worst-case upper-bound approximation method. However, further review reveals that many factors interact to create the measured spectral content of Figure 5.

The first observation is that beyond a certain frequency the spectral content decreases as predicted by the upper-bound approximation. However, instead of decreasing to zero, the spectral content is asymptotic to the ambient noise level.

Secondly, the peak value is measured at 240 MHz, not the fundamental frequency of 10 MHz. In fact, the value at 10 MHz is much lower than that at 240 MHz. This phenomenon is due to the relationship between the physical dimensions of the PCB signal trace (the radiating antenna) and the wavelength of the frequencies being produced.

The *quarter-wavelength approximation* is an easy way to predict which antennae within a system will radiate what frequencies best. A symmetrical, periodic waveform will achieve a maxima at one quarter-wavelength, $\pi/2$ radians, and a minima at three quarter-wavelength, $3\pi/2$ radians.

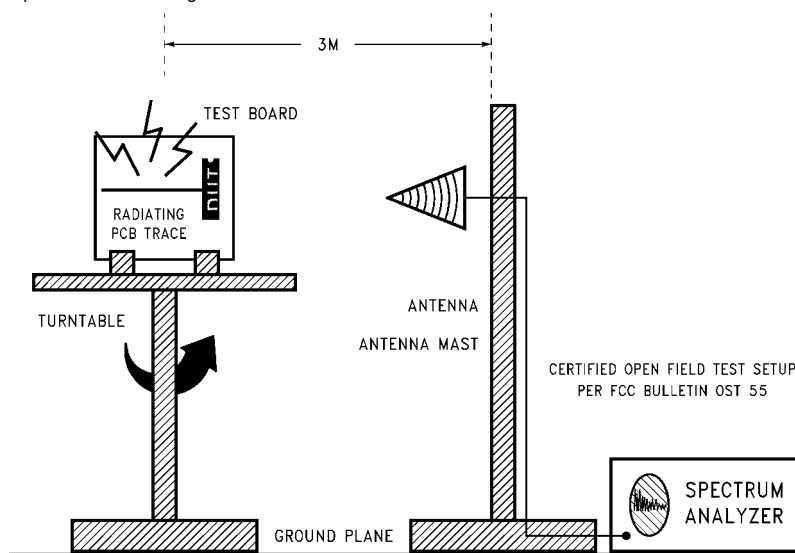

FIGURE 4. Radiated EMI Measurement Method

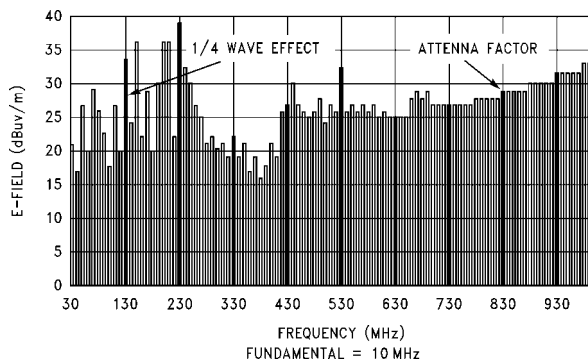

FIGURE 5. Example of Radiated Method Spectral Content

Above one quarter-wavelength, the absolute magnitude of amplitude will not be greater than that at one quarter-wavelength. Below one quarter-wavelength, the amplitude is proportional to the length of the antenna (up to one quarter-wavelength). Therefore, frequencies whose quarter-wavelengths are the same as, or shorter than, the given antenna length (26 cm in the above example) will radiate the maximum amplitude possible at the antenna wavelength frequency, then decay at a rate of 20 dB or 40 dB per decade. Frequencies whose quarter-wavelengths are longer than the antenna length will decrease proportionally to the increase in wavelength.

Another variable that will effect results is the *antenna factor*. Each type of antenna has its own sensitivity signature across different bands. As a result, the antenna manufacturer specifies an antenna factor. This factor is mathematically added to, or subtracted from, the measured amplitude in order to compensate for lack of sensitivity to some bands and over-sensitivity to others. The result is that the frequency plot appears to show some frequencies measuring below the ambient and other frequencies measuring large values at high frequencies (indicated by a stairstep function). These apparent measured values are simply manifestations of the antenna factor.

Figure 6 illustrates another method, *The Direct Contact Measurement Method (DCM)*, of measuring the spectral content of an IC-generated signal. The drawback of the Radiated Measurement Method was the inability to clearly characterize the signal's spectral content due to variables such as ambient noise levels, quarter-wavelength effects, and antennae factors. The DCM method eliminates these variables by measuring the spectral response of an IC signal directly from the IC output pin.

Figure 7 illustrates the spectral content as measured by the DCM method. It is a more predictable response based on the worst-case upper bound approximation method. The results are easily measurable to 1 GHz. Note that Figure 7 is plotted on a linear scale. A semilog scale would clearly demonstrate a -20 dB and -40 dB/decade decay as illustrated in Figure 8.

THE DIRECT CONTACT MEASUREMENT METHOD (DCM)

The DCM Method differs from the Radiated Measurement Method in that the spectral energy is measured by contacting the pin of a single integrated circuit directly. Hence, this method does not directly reflect radiated system EMI, as tested in the FCC Method 55. The DCM tests a single output of an integrated circuit for harmonic frequency content. The DCM method is very useful in analyzing the frequency content of a particular IC technology in comparison to another. Therefore, the DCM method provides baseline comparative data from which to select logic IC technologies that may best *enhance* EMC system design.

Fairchild Semiconductor's Advanced Logic Applications Engineering has tested a number of devices using the DCM to obtain insight into how much an individual IC may contribute to total EMI. The method is described below.

TEST FIXTURE VERSUS "DEAD-BUG STYLE"

The environment where the IC-under-test resides is critical to the production of accurate data. While performing measurements in the lab it was determined that some filtering effects were present when using a test fixture. Wide or narrow resonant frequency bands may be set up by distributed components which exist on test boards. These resonances, if ignored, may add to or subtract from the measured spectral content of the IC. Subsequently it was determined that a "dead-bug" test environment had the fewest spurious responses.

The "dead-bug" style of test fixture is simply a copper-plated piece of circuit board with the IC soldered up-side-down onto it. The IC is held into place by soldering the ground pin(s) directly to the copper plating. The copper-plate is an excellent ground plane, providing for minimal distributed components. Power is connected with a short twisted pair of 16-gauge wire or higher. Decouple the power at the device pin using both low- and high-frequency bypassing chip capacitors. Unused inputs may be conveniently soldered to the ground plane if appropriate. This will further stabilize the IC as well.

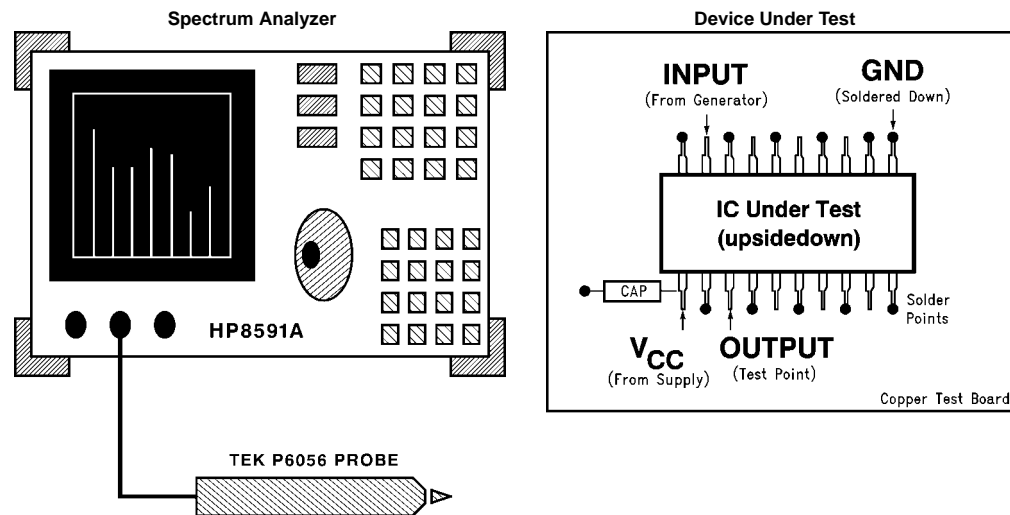

FIGURE 6. Direct Contact Measurement Method

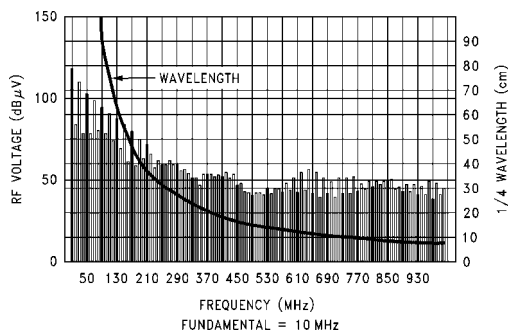

FIGURE 7. Example of DCM Method Spectral Content

DCM EQUIPMENT

The primary equipment is the spectrum analyzer and an appropriate high-frequency probe. The probe must be selected with careful consideration given to the bandwidth, as well as the loading effect it will have on the circuit. Ideal probe bandwidth should be flat from 1 MHz to 1 GHz. Several probes were tested for these measurements and the Tektronix P6056 was found to be well suited in these applications. The probe has a relatively flat response out to 1 GHz and a load specification of 1 pF.

The IC to be tested is either inserted into a test fixture or soldered dead-bug style (as described above). A power supply must be furnished along with a signal generator since the IC must be powered and toggled.

THE DCM PROCEDURE

The procedure is very simple when compared to the radiated measurement method. A basic understanding of the operation of the spectrum analyzer is required. Special attention is advised when setting the bandwidth resolution filter system since spectral information can be masked if it is not set properly. Refer to the analyzer manual for more details.

The following are the basic steps involved when testing an IC using the DCM method:

1. The IC is setup on the test platform (as described above).
2. Power is supplied to the IC.
3. A pulse generator is applied to the appropriate input pin. Usually a frequency of 1 MHz is used, however, any span or band may be set and observed using the spectrum analyzers' functions. Resolution of the spectral output is set by the input frequency and bandwidth filter.
4. The spectrum analyzer is set up with an appropriate 50Ω input and a high frequency probe.
5. The IC is probed directly on the output pin and the spectral content is measured and captured.
6. The captured digital data can then be processed for display or comparison to another IC.

Figure 9 illustrates some typical spectral outputs and how they can be used to compare various logic IC technologies. The digitized data can be processed to analyze specific bands of concern, if necessary.

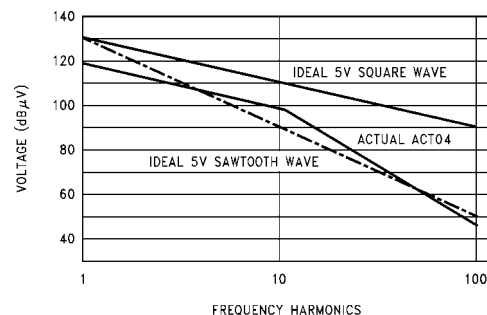

FIGURE 8. Ideal versus Actual Spectral Response

THE ROLE OF SPECTRAL CONTENT AND LOGIC ICs

Understanding the role of the spectral content of EMI is important for several reasons. FCC limitations on EMI emissions is regulated in frequency bands. For example, FCC Class A radiated emissions limits measured at a distance of 3 meters are:

- 300 $\mu\text{V}/\text{m}$ from 30 MHz to 68 MHz,
- 500 $\mu\text{V}/\text{m}$ from 88 MHz to 216 MHz, and
- 700 $\mu\text{V}/\text{m}$ from 216 MHz to 1000 MHz

Also, the dimensions of the radiating medium (e.g., PCB traces or ribbon cables) will affect the amplitude of the radiated energy. By accurately predicting or observing the spectral characteristics by band and their relation to the FCC limit, the system designer can choose or alter certain PCB layout or design techniques as well as choose the logic technology best suited for minimum spectral content for a particular band and antenna type.

Keep in mind that the DCM method of comparing ICs will only provide baseline spectral data. First of all, the DCM is usually done without any load to the IC output. This tends to bring out worst-case spectral content because of the resultant sharpness of an unloaded output signal edge. In a system, capacitive and DC loading will affect the edge, and this in turn will affect the spectral content. The relative order of IC technologies may also change depending on how each of the technologies react to heavier loads.

The spectral content resultant from using the DCM method will also be different than that measured in a system using the FCC radiated method. Various aspects of the PCB design (traces, impedance, layout, other components, etc.) will either amplify or attenuate various harmonics and result in a different spectral signature for the system. However, using the DCM method to choose an IC technology to best complement good EMC system design will result in the lowest possible radiated EMI.

THE SYSTEM—TRANSMITTERS AND ANTENNAE

The simplest model for the phenomena of EMI is that of a transmitter generating a signal onto an antenna which is subsequently broadcast into the ether. In a portable computer the transmitter is any signal or noise generated either directly by an IC output or indirectly through some noise mechanism.

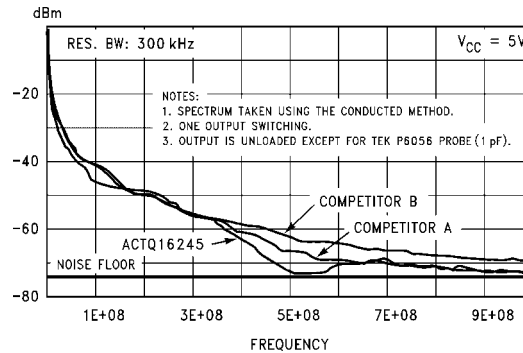

FIGURE 9. Example of 16245 DCM Spectral Comparison

In a system the antennae are made up of PCB traces, jumper wires, I/O cables, power cords, and enclosure apertures. It is the interaction of these antennae with spectral content of the transmitted signal that will determine how much total energy is radiated. Longer antennae mean more higher-amplitude, lower-frequency content will be radiated efficiently. Conversely, if a signal is rich in higher-frequency content, then more traces will behave as efficient antennae. This fundamental relationship is the basic premise to reducing EMI generation.

IC TECHNOLOGY SELECTION

One way of minimizing the transmitter side of the equation is to select IC technologies which exhibit minimal spectral energy. Spectral energy is a function of signal period, duty cycle, rise and fall times, transition corners, amplitude, and noise.

Portable computer design usually necessitates use of a CMOS technology for lowest power. Low-end systems (16 MHz and below) can be implemented in slower CMOS technologies, such as HCMOS, which have slow, smooth, and relatively gradual signal transitions and low spectral content. Systems operating above 20 MHz are implemented in faster advanced CMOS technologies with sharp transitions and fast rise/fall times. These devices generate more high-frequency signals. These larger bandwidths result in larger amounts of spectral energy. Some new, high-performance CMOS technologies include output waveshaping circuitry to control spectral noise due to the sharpness of the output signal transition. This type of noise control circuitry is currently employed in ACMOS logic, programmable GALs, and in some memory devices.

The spectral plot in Figure 9 shows the reduced energy on Fairchild Semiconductor's FACT Quiet Series™ (ACTQ) logic as compared to the first generation ACT logic. Spectral content reduction is accomplished by slowing edges, rounding sharp transition corners, and reducing under-shoot through current injection techniques.

ELIMINATING NOISE SOURCES

Technology selection is crucial in minimizing spectral content of a wanted signal. Other sources of EMI come from unwanted, spurious noise. IC technologies which provide waveshaping may relieve some types of device-generated noise such as ground bounce or may minimize transmission line effects through edge rate reduction, however, total control of system noise is obtained through prudent board level design techniques.

One of the largest contributors to EMI on the board level is transmission line ringing. When a signal's edge rate is significantly faster than the propagation delay of the medium of which it's traversing, then that medium will cease behaving as a 0Ω metallic connection and begin to exhibit transmission line effects. In this case, if the impedance at either end of the transmission line differs from the impedance of the transmission line, then reflections and subsequent ringing will occur. In addition to the incident wave, reflections traversing back and forth on the transmission line will also generate substantial EMI. Also, transmission line ringing is rich in frequency content but can easily be controlled through proper termination technique. Terminating transmission lines can cut EMI emissions by 50% or more.

For CMOS-driven transmission lines two termination techniques are recommended to maintain low power. The first is the AC parallel termination. This scheme matches the effective impedance of the transmission line with a resistor implemented in a parallel termination fashion. However, for the AC termination, a DC-blocking capacitor is used to eliminate the logic HIGH state DC bias currents (typically a capacitance of 100 pF–400 pF is used). The oscillographs in Figure 10 show transmission line ringing for an ACMOS logic IC driving a 36', 50Ω coaxial cable before and after AC termination. The improvement in signal quality was gained by placing an AC termination at the end of the coax cable.

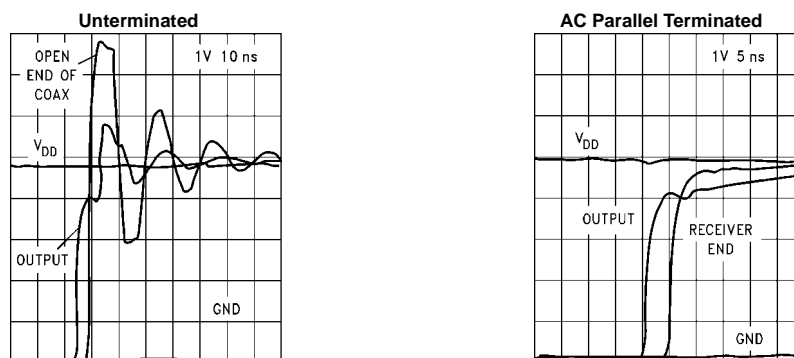

FIGURE 10. Terminating Transmission Lines

The second termination scheme is the series termination. This scheme is less expensive than the AC termination because it eliminates the cost of the capacitor. The series termination places a resistor in series with the output driver and the transmission line. The resistor value is picked such that when added to the IC output resistance, the total equals the effective impedance of the transmission line. This in effect forms a voltage divider with the transmission line producing a half-voltage level at the source which doubles upon reflection at the end of the line. The value of this scheme for EMI reduction is the current limiting behavior of the series resistor. However, because this termination develops a half-level incident signal it is only recommended for point load driving. For distributed loading, the AC parallel termination technique is recommended.

CONTROLLING CROSSTALK

Similar to transmission line ringing, crosstalk is a key source of system level noise-generated EMI. Both noise phenomena occur on electrically long lines, meaning the signals are inherently driving long antennae facilitating maximum spectral radiation. Crosstalk occurs when a transition on an active transmission element (PCB trace, wire, cable) is inductively and capacitively coupled to a passive element inducing a narrow, frequency-rich voltage pulse on the passive element. The two transmission elements are typically physically close for a long distance in order to have enough mutual inductance and capacitance to provide significant coupling. Most crosstalk control is provided by eliminating these long adjacent runs.

For printed circuit boards the layout shown in Figure 11 is recommended. Adjacent signal layers are oriented with all traces running in a perpendicular direction. Long parallel traces on these layers can be shielded with interlaced ground traces. The most sensitive and longest signals (usually asynchronous) can be placed with generous spacing on a separate signal layer which is isolated from the rest of the layers by either a ground or V_{CC} plane.

MINIMIZING STRAY INDUCTANCE

In addition to creating ground and V_{CC} bounce, stray inductance can increase high-frequency current transients in signal paths. Common contributors to stray inductance are IC sockets, edge connectors, and the use of error-correcting jumper wires. Error-correcting jumper wires pose the additional problem of forming a very efficient antenna because their electromagnetic fields are less disrupted by the ground plane than the original PCB trace which they replaced. For this reason the use of these jumper wires as a permanent fix is discouraged (as is the use of IC sockets). However, if necessary, twisted-pair corrections can be used with one wire in the pair connected to ground.

POWER RAIL NOISE AND DECOUPLING

Power rail noise can be the largest contributor to EMI in a system because, inherently, power rails represent the loops which carry the largest amount of current in the system. The primary mechanism for controlling power rail noise is minimizing the impedance from V_{CC} to ground. This is largely accomplished by the use of dedicated power and ground planes. Power planes can provide a 50 to 1 reduction in V_{CC} to ground impedance over busing schemes. Additionally, power planes provide low-inductance paths to ground for all ICs on the board, minimizing ground bounce and V_{CC} bounce.

Today most portable computers utilize surface mount packaging to meet size restrictions. There is a natural tendency among designers to gang power connections from several ICs' power pins. This is not recommended in that it increases V_{CC} -to-ground loop inductance, generating frequency-rich pulses onto potentially long antennae. Each surface mounted IC's ground and V_{CC} pins should be connected directly, via a plated-through hole(s), to the proper power plane.

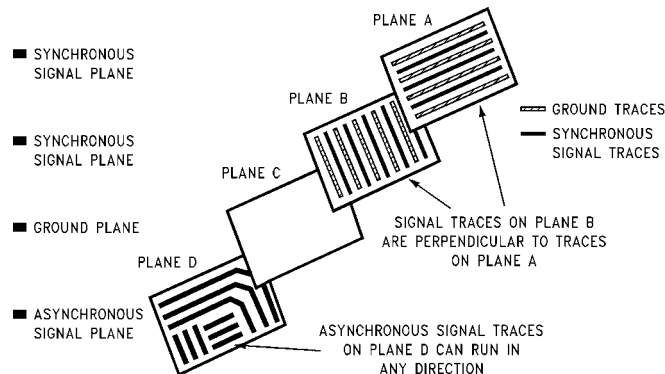

FIGURE 11. Crosstalk Design Recommendations

Decoupling is the most powerful tool in combating power rail noise. Local demands for current can cause the V_{CC} rail to vary. This can be offset by placing decoupling capacitors in close proximity to the power and ground pins of every IC on the board. These capacitors will supply charge when current is in demand. A minimum of a 0.1 μF , low ESL, ceramic chip capacitor is recommended. For added lower-frequency filtering, a 1.0 μF tantalum capacitor can be added in parallel with the 0.1 μF ceramic capacitor. These capacitors also act as a high-frequency short circuit, effectively reducing the length of the V_{CC} -to-ground loop as they are distributed along the board. Because portable computers implement bus architectures where many IC's can switch simultaneously, it is also prudent to add 10 μF to 100 μF of electrolytic bulk capacitance where power enters the board. This will smooth gross demands for current.

EMI SHIELDING TECHNIQUES

Theoretically any system can be designed to radiate 0 dB EMI to the outside world if it is encapsulated within a perfectly homogenous metal enclosure. Unfortunately computing equipment requires many interfaces to the outside world which leaves holes, gaps, seams, and other apertures in the enclosure. These must be dealt with individually.

Desktop PCs have long used solid metallic enclosures for excellent shielding, however, laptop and notebook PCs, with stringent weight requirements, can seldom afford the luxury. Most portable computers utilize conductive plastics, flashed or painted metallic interior, or the use of light weight metallic foils. Conductive plastic is formed by impregnating standard plastic with metallic beads. This forms the most homogenous enclosure because the whole process is molded but tends to be the most expensive of the three techniques.

Once the system is successfully enclosed, apertures will have to be taken care of. Any aperture will act as a slot antenna whose efficiency is directly proportional to the size of opening. Keyboards, displays, switches, LEDs, cooling slots, disk drive slots, expansion slots, connectors, and enclosure seams all form apertures from which EMI will escape the enclosure. Large openings like displays and cooling slots can be covered with wire mesh screening, which effectively divides up the single large slot into a matrix of substantially smaller slots. Many displays use conductive coatings as an alternative to, or in addition to, the mesh.

Conductive sealants and gaskets can be used on seams. Also, all connectors should be properly grounded to the board or chassis ground. The connector ground should be uniformly soldered or sealed to the enclosure.

Coaxial cable and/or ribbon cable with alternating ground wires should be used for all I/O connections. Ribbon cables wrapped within a metallic plastic sheath are also commercially available. Again, careful attention should be paid to the proper connection of grounds.

EMI control should be considered at the very beginning of portable computer design. Techniques for meeting FCC emissions guidelines include selecting low noise IC technologies, minimizing system and power rail noise through proper design technique, and shielding the remaining noise with proper enclosure design. All of these techniques add cost to the end system, but this cost is trivial compared to the cost of retrofitting a failing system.

In addition, employing good EMI design practice will improve system signal integrity by minimizing crosstalk, ringing, ground bounce, etc. These techniques will also improve system reliability by removing overshoot/undershoot stresses and improving ESD protection with a properly shielded enclosure.

CONCLUSION

Measuring the spectral content of an IC's output signal can be done by measuring radiated EMI using the FCC OST55 method. An alternative method for measuring the true spectral characteristics of the waveform can be done by direct contact, eliminating some possibly confusing variables. Combined with proper system layout and design the choice of an inherently low-EMI technology logic IC is the first step to a high-performance, low-EMI system design.

REFERENCES

1. J.L. Norman Violette, Donald R.J. White, and Michael F. Violette, *Electromagnetic Compatibility Handbook*, Van Nostrand Reinhold Co., New York, 1987.
2. "Device Generated Noise Measurement Techniques", Applications Note 737, Fairchild Semiconductor Corp., January 1991.
3. "FACT™ Advanced CMOS Logic Databook", Fairchild Semiconductor Corp., 1990.

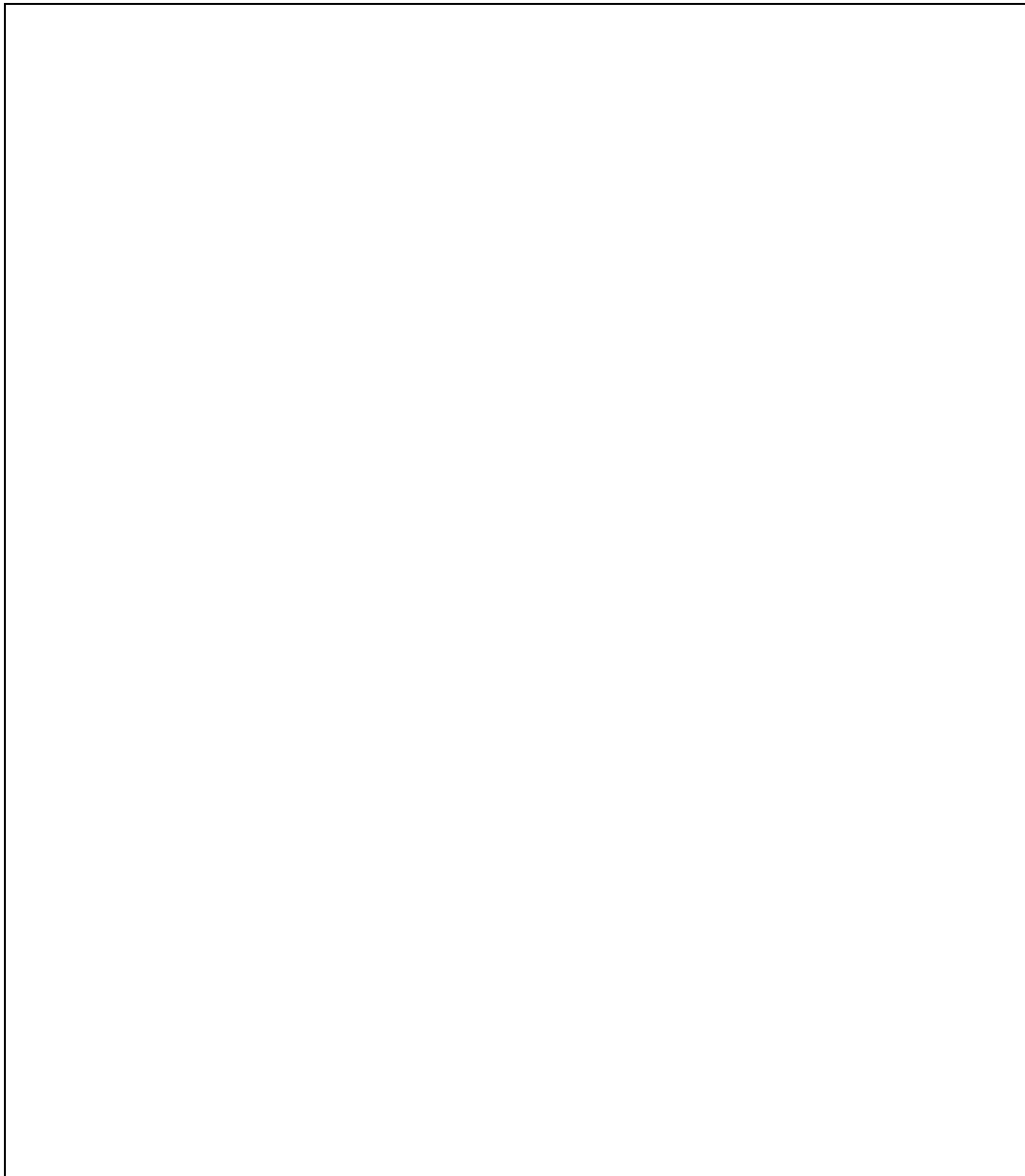

Fairchild does not assume any responsibility for use of any circuitry described, no circuit patent licenses are implied and Fairchild reserves the right at any time without notice to change said circuitry and specifications.

LIFE SUPPORT POLICY

FAIRCHILD'S PRODUCTS ARE NOT AUTHORIZED FOR USE AS CRITICAL COMPONENTS IN LIFE SUPPORT DEVICES OR SYSTEMS WITHOUT THE EXPRESS WRITTEN APPROVAL OF THE PRESIDENT OF FAIRCHILD SEMICONDUCTOR CORPORATION. As used herein:

1. Life support devices or systems are devices or systems which, (a) are intended for surgical implant into the body, or (b) support or sustain life, and (c) whose failure to perform when properly used in accordance with instructions for use provided in the labeling, can be reasonably expected to result in a significant injury to the user.
2. A critical component in any component of a life support device or system whose failure to perform can be reasonably expected to cause the failure of the life support device or system, or to affect its safety or effectiveness.

www.fairchildsemi.com