



May, 2003

Application Note 9030

DIP-Smart Power Module Test Board II

**SPM™ TEST BOARD for use in Direct Interface with CPU
(using 1-Shunt Resistor)**

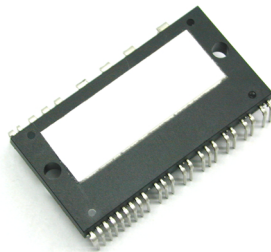

Schematics and External Interface Diagram

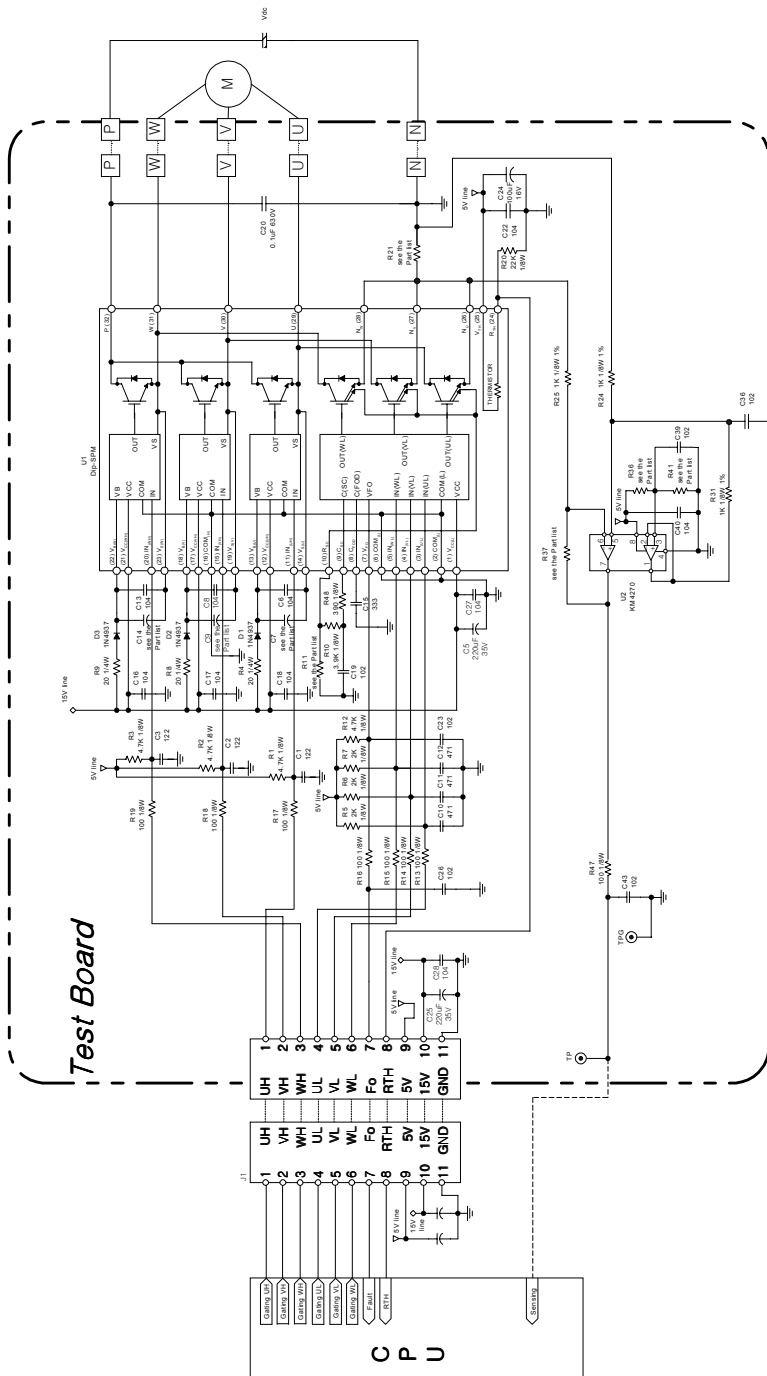

Note)

1. Common-grounded power supplies of +5V and +15V are used for CPU and Dip-SPM operation.
2. For further details, see the datasheet and application note.

PCB Map

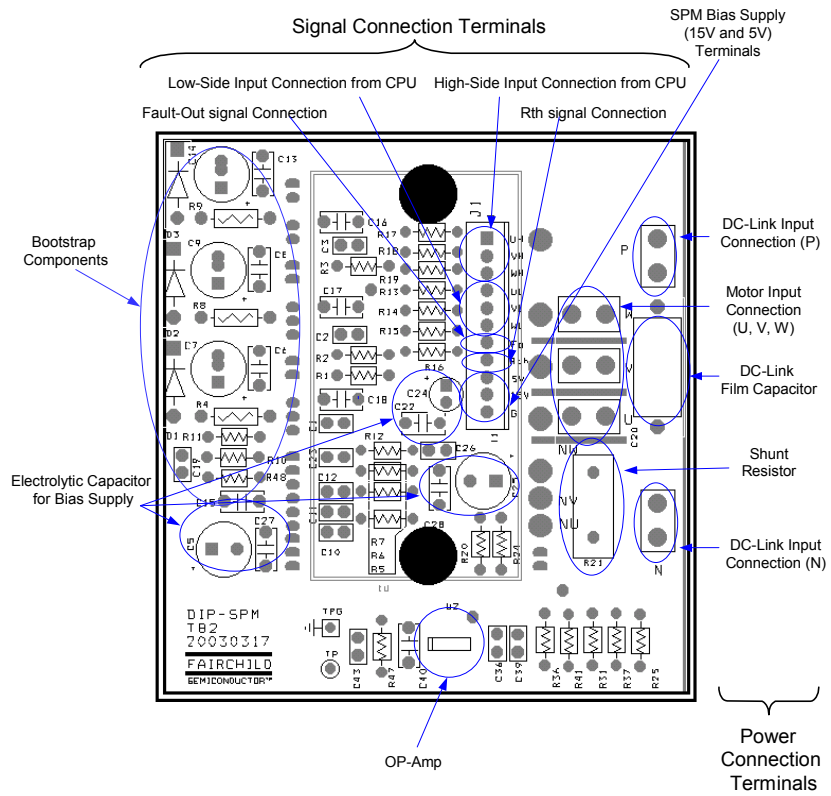

External Connection

Signal	1	High-Side Input Signal from CPU (Phase U)
	2	High-Side Input Signal from CPU (Phase V)
	3	High-Side Input Signal from CPU (Phase W)
	4	Low-Side Input Signal from CPU (Phase U)
	5	Low-Side Input Signal from CPU (Phase V)
	6	Low-Side Input Signal from CPU (Phase W)
	7	Fault-Out Signal to CPU
	8	SPM Bias Supply +5V Terminal
	9	SPM Bias Supply +15V Terminal
	10	SPM Bias Supply Ground Terminal
Power Connection	P	Positive DC Link Input Connection
	N	Negative DC Link Input Connection
	U	Motor Input Connection (Phase U)
	V	Motor Input Connection (Phase V)
	W	Motor Input Connection (Phase W)

Photograph of Assembled PCB

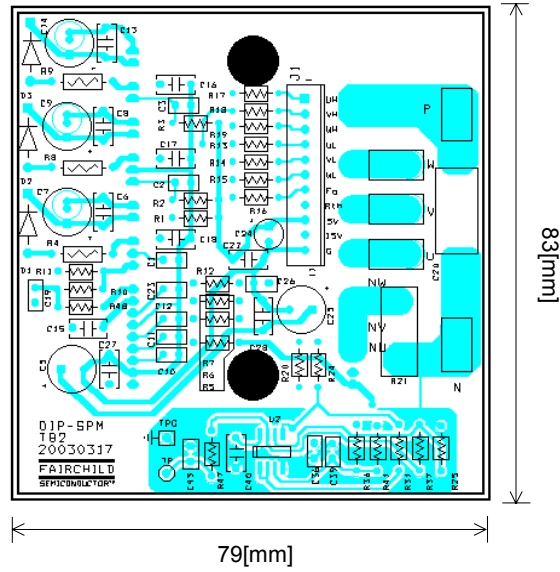

(a) Top Side View

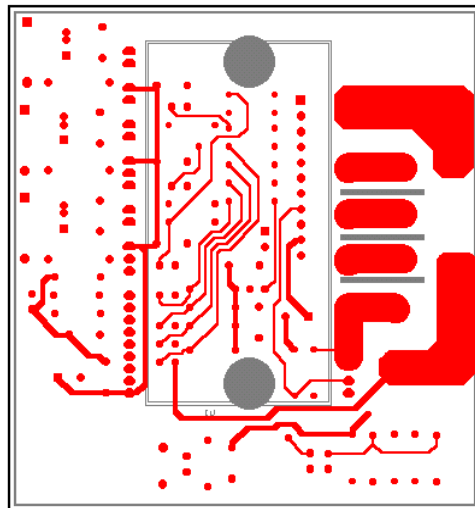

(b) Bottom Side View

Part List 1

Part No.	Rating	Characteristics	Definition
R1	4.7k Ω , 1/8W	Carbon Film Resistor (5%)	Pull-Up Resistor (UH)
R2	4.7k Ω , 1/8W	Carbon Film Resistor (5%)	Pull-Up Resistor (VH)
R3	4.7k Ω , 1/8W	Carbon Film Resistor (5%)	Pull-Up Resistor (WH)
R4	20 Ω , 1/4W	Carbon Film Resistor (5%)	Bootstrap Resistor (Phase U)
R5	2k Ω , 1/8W	Carbon Film Resistor (5%)	Pull-Up Resistor (UL)
R6	2k Ω , 1/8W	Carbon Film Resistor (5%)	Pull-Up Resistor (VL)
R7	2k Ω , 1/8W	Carbon Film Resistor (5%)	Pull-Up Resistor (WL)
R8	20 Ω , 1/4W	Carbon Film Resistor (5%)	Bootstrap Resistor (Phase V)
R9	20 Ω , 1/4W	Carbon Film Resistor (5%)	Bootstrap Resistor (Phase W)
R10	3.9k Ω , 1/8W	Carbon Film Resistor (5%)	Low-Pass-Filter for Current Sensing
R11	1/8W	Carbon Film Resistor (5%)	Current Sensing Resistor - refer to the datasheet or note2
R12	4.7k Ω , 1/8W	Carbon Film Resistor (5%)	Pull-Up Resistor (Fault-Out)
R13	100 Ω , 1/8W	Carbon Film Resistor (5%)	Series Resistor for Signal Interface (UL)
R14	100 Ω , 1/8W	Carbon Film Resistor (5%)	Series Resistor for Signal Interface (VL)
R15	100 Ω , 1/8W	Carbon Film Resistor (5%)	Series Resistor for Signal Interface (WL)
R16	100 Ω , 1/8W	Carbon Film Resistor (5%)	Series Resistor for Signal Interface (Fault-Out)
R17	100 Ω , 1/8W	Carbon Film Resistor (5%)	Series Resistor for Signal Interface (UH)
R18	100 Ω , 1/8W	Carbon Film Resistor (5%)	Series Resistor for Signal Interface (VH)
R19	100 Ω , 1/8W	Carbon Film Resistor (5%)	Series Resistor for Signal Interface (WH)
R20	22k Ω , 1/8W	Carbon Film Resistor (5%)	Voltage Divider Resistor for Thermistor
R21	m Ω , 5W	Non-inductive Resistor (1%)	Shunt Resistor for Current Sensing - refer to Note1
R24	1k Ω , 1/8W	Carbon Film Resistor (1%)	Op-amp's (+) Input Resistor
R25	1k Ω , 1/8W	Carbon Film Resistor (1%)	Op-amp's (-) Input Resistor
R31	1k Ω , 1/8W	Carbon Film Resistor (1%)	Op-amp's (+) Input Bias Resistor
R36	1/8W	Carbon Film Resistor (1%)	Voltage Divide Resistor for Op-amp's Input - refer to Note1
R37	1/8W	Carbon Film Resistor (1%)	Op-amp's Feed Back Resistor - refer to Note1
R41	1/8W	Carbon Film Resistor (5%)	Voltage Divide Resistor for Op-amp's Input - refer to Note1
R47	100 Ω , 1/8W	Carbon Film Resistor (5%)	Op-amp's Output Series Resistor
R48	390 Ω , 1/8W	Carbon Film Resistor (5%)	Series Resistor for Csc

Part List 2

Part No.	Rating	Characteristics	Definition
C1	1.2nF	Ceramic Capacitor	High-Side Pull-Up Capacitor (Phase U)
C2	1.2nF	Ceramic Capacitor	High-Side Pull-Up Capacitor (Phase V)
C3	1.2nF	Ceramic Capacitor	High-Side Pull-Up Capacitor (Phase W)
C5	220 μ F, 35V	Electrolytic Capacitor	+15V Bias Voltage Source Capacitor
C6	100nF	Ceramic Capacitor	Bypass Capacitor for Bootstrap Supply (Phase U)
C7	220 μ F, 35V	Electrolytic Capacitor	Bootstrap Capacitor (Phase U) - for washing machines
	33 μ F, 35V		Bootstrap Capacitor (Phase U) - for air conditioners
C8	100nF	Ceramic Capacitor	Bypass Capacitor for Bootstrap Supply (Phase V)
C9	220 μ F, 35V	Electrolytic Capacitor	Bootstrap Capacitor (Phase V) - for washing machines
	33 μ F, 35V		Bootstrap Capacitor (Phase V) - for air conditioners
C10	470pF	Ceramic Capacitor	Low-Side Pull-Up Capacitor (Phase U)
C11	470pF	Ceramic Capacitor	Low-Side Pull-Up Capacitor (Phase V)
C12	470pF	Ceramic Capacitor	Low-Side Pull-Up Capacitor (Phase W)
C13	100nF	Ceramic Capacitor	Bypass Capacitor for Bootstrap Supply (Phase W)
C14	220 μ F, 35V	Electrolytic Capacitor	Bootstrap Capacitor (Phase W) - for washing machines
	33 μ F, 35V		Bootstrap Capacitor (Phase W) - for air conditioners
C15	33nF	Ceramic Capacitor	Capacitor for Selection for Fault Out Duration
C16	100nF	Ceramic Capacitor	+15V Bias Voltage Bypass Capacitor (WH)
C17	100nF	Ceramic Capacitor	+15V Bias Voltage Bypass Capacitor (VH)
C18	100nF	Ceramic Capacitor	+15V Bias Voltage Bypass Capacitor (UH)
C19	1nF, 25V	Ceramic Capacitor	Low-Pass-Fault for Current Sensing
C20	0.1 μ F, 630V	Film Capacitor	Snubber Capacitor to Suppress the Spike-Voltage
C22	100nF	Ceramic Capacitor	+5V Bias Voltage Source Capacitor
C23	1nF	Ceramic Capacitor	Pull-Up Capacitor of Fault-Out Signal
C24	100 μ F, 16V	Electrolytic Capacitor	+5V Bias Voltage Source Capacitor
C25	220 μ F, 35V	Electrolytic Capacitor	+15V Bias Voltage Source Capacitor
C26	1nF	Ceramic Capacitor	Bypass Capacitor for Fault-Out Signal
C27	100nF	Ceramic Capacitor	+15V Bias Voltage Source Capacitor
C28	100nF	Ceramic Capacitor	+15V Bias Voltage Source Capacitor
C36	1nF	Ceramic Capacitor	Bypass Capacitor for Op-amp's (+) Input
C39	1nF	Ceramic Capacitor	Bypass Capacitor for Op-amp's (-) Input
C40	100nF	Ceramic Capacitor	+5V Bias Voltage Bypass Capacitor for Op-amp
C43	1nF	Ceramic Capacitor	Bypass Capacitor for Op-amp's Output Signal
D1	1A, 600V	Fast Recovery Diode, (1N4937)	Bootstrap Diode (Phase U)
D2	1A, 600V	Fast Recovery Diode, (1N4937)	Bootstrap Diode (Phase V)
D3	1A, 600V	Fast Recovery Diode, (1N4937)	Bootstrap Diode (Phase W)
TP	-	Test Pin	Test Point for Op-amp's Output Signal
TPG	-	Test Pin	Test Point GND
U2	KM4270	4-Channel Op-amp	Op-amp for Phase Current Sensing
U1	-	DIP-SPM	See the datasheet.

Note 1. Circuit of Differential Amplifier

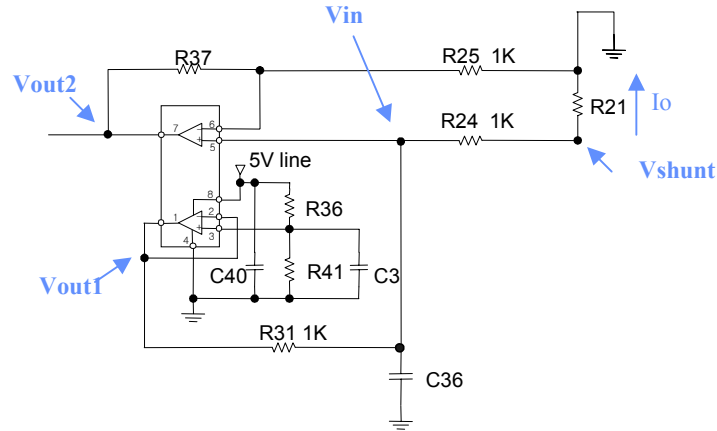

Figure 1. Circuit of Current Sensing Part

1. How to select component values.

- 1) Choose shunt resistor (R21) value.
- 2) Set the short-circuit current level.
=> It make R11 value.
(Refer to the Fig of Rsc variation by chang of shunt resistors for short-circuit protection).
- 3) Set the Vout2 value when Io=0.
=> typ. Vout2=2.5V when Op-amp's Vcc=5V and CPU's Vcc=5V.
- 4) Set maximum Vout2 when short-circuit is happened.
=> typ. Vout2=4.5V(@ Io=150%Ic)

2. How to calculate component values.

Where, SPM=FSAM10SH60A, R21=50mohm, short-circuit current level=15A (150%Ic),
Vout2=2.5V (@ Io=0A), Vout2=4.4V (Io=15A),
op-amp's offset voltage=0V

$$1) Vout1 = (R41 \times 5V) / (R41 + R36) \quad \text{--- (1-1)}$$

$$2) Vin = (Vshunt + Vout1) / 2 \quad \text{--- (2-1)}$$

$$3) Vout2 = (1 + R37 / R25) \times Vin \quad \text{--- (3-1)}$$

$$\text{So, } Vout2 = (1 + R37 / R25) \times ((Vshunt + Vout1) / 2) \quad \text{--- (3-2)}$$

4) We can get two equations from (3-2).

First, when Io=0A & Vshunt=0V

$$2.5V = (1 + R37 / 1k\Omega) \times (Vout1 / 2) \quad \text{--- (4-1)}$$

Second, when Io=15A & Vshunt=0.75V

$$4.4V = (1 + R37 / 1k\Omega) \times ((0.75V + Vout1) / 2) \quad \text{--- (4-2)}$$

So, from equation (4-1) & (4-2)

$$\underline{R37 = 4k\Omega, Vout1=0.98V}$$

5) If R41=10kΩ, then R36=40kΩ

3. Recommended values (unit : Ω)

SPM Current Rating	R21, 22, 23	R37, 38, 39	R41	R36
10A	50m	3.9k	10k	39k
15A	40m	3.3k	10k	33k
20A	30m	3.3k	10k	33k
30A	20m	3.3k	10k	33k

Note 2. Fig of Rsc Variation of Shunt Resistor for Short-circuit Protection

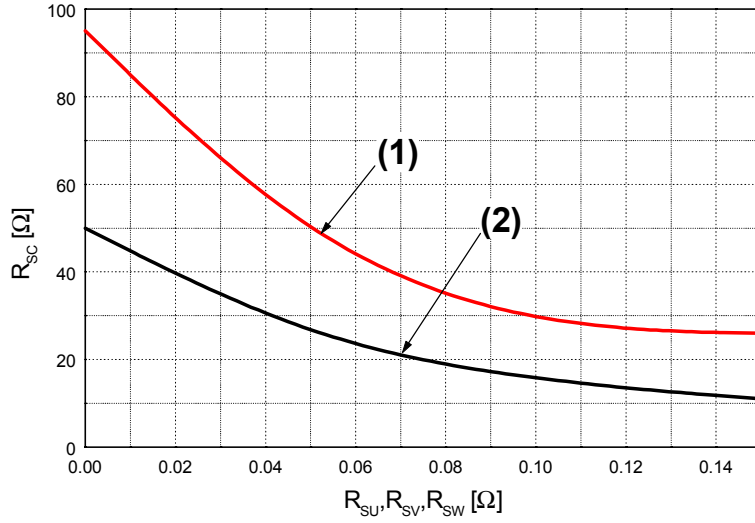

Fig. 2. 10A rated SPM
 (1) @ around 100% Rated Current Trip ($I_c = 10A$),
 (2) @ around 150% Rated Current Trip ($I_c = 15A$)

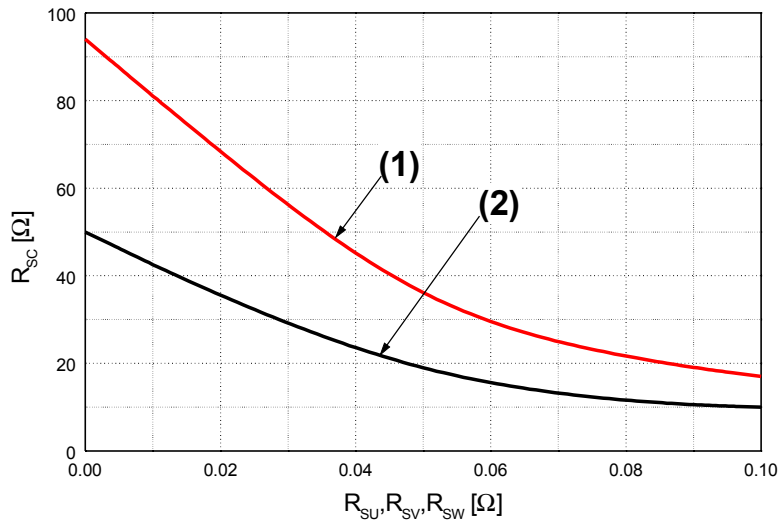

Fig. 3. 15A rated SPM
 (1) @ around 100% Rated Current Trip ($I_c = 15A$),
 (2) @ around 150% Rated Current Trip ($I_c = 22.5A$)

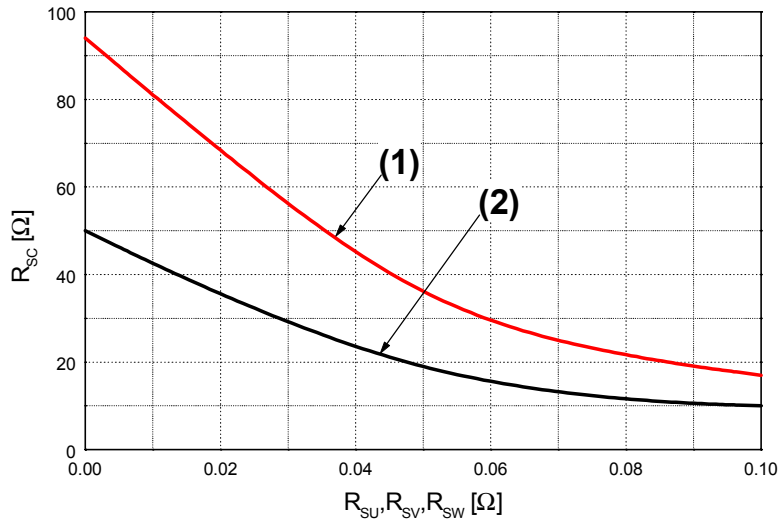

Fig. 4. 20A rated SPM
 (1) @ around 100% Rated Current Trip ($I_c = 25A$),
 (2) @ around 150% Rated Current Trip ($I_c = 30A$)

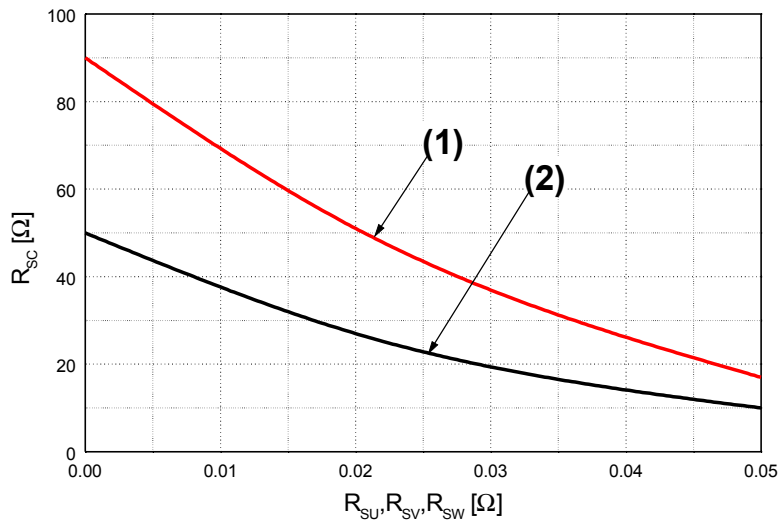

Fig. 5. 30A rated SPM
 (1) @ around 100% Rated Current Trip ($I_c = 30A$),
 (2) @ around 150% Rated Current Trip ($I_c = 45A$)

TRADEMARKS

The following are registered and unregistered trademarks Fairchild Semiconductor owns or is authorized to use and is not intended to be an exhaustive list of all such trademarks.

ACEx™	FACT™	ImpliedDisconnect™	PACMAN™	SPM™
ActiveArray™	FACT Quiet Series™	ISOPLANAR™	POP™	Stealth™
Bottomless™	FAST®	LittleFET™	Power247™	SuperSOT™-3
CoolFET™	FASTr™	MicroFET™	PowerTrench®	SuperSOT™-6
CROSSVOLT™	FRFET™	MicroPak™	QFET™	SuperSOT™-8
DOME™	GlobalOptoisolator™	MICROWIRE™	QS™	SyncFET™
EcoSPARK™	GTO™	MSX™	QT Optoelectronics™	TinyLogic®
E ² CMOS™	HiSeC™	MSXPro™	Quiet Series™	TruTranslation™
EnSigna™	ꞆC™	OCX™	RapidConfigure™	UHC™
Across the board. Around the world.™		OCXPro™	RapidConnect™	UltraFET®
The Power Franchise™		OPTOLOGIC®	SILENT SWITCHER®	VCX™
Programmable Active Droop™		OPTOPLANAR™	SMART START™	

DISCLAIMER

FAIRCHILD SEMICONDUCTOR RESERVES THE RIGHT TO MAKE CHANGES WITHOUT FURTHER NOTICE TO ANY PRODUCTS HEREIN TO IMPROVE RELIABILITY, FUNCTION OR DESIGN. FAIRCHILD DOES NOT ASSUME ANY LIABILITY ARISING OUT OF THE APPLICATION OR USE OF ANY PRODUCT OR CIRCUIT DESCRIBED HEREIN; NEITHER DOES IT CONVEY ANY LICENSE UNDER ITS PATENT RIGHTS, NOR THE RIGHTS OF OTHERS.

LIFE SUPPORT POLICY

FAIRCHILD'S PRODUCTS ARE NOT AUTHORIZED FOR USE AS CRITICAL COMPONENTS IN LIFE SUPPORT DEVICES OR SYSTEMS WITHOUT THE EXPRESS WRITTEN APPROVAL OF FAIRCHILD SEMICONDUCTOR CORPORATION.

As used herein:

1. Life support devices or systems are devices or systems which, (a) are intended for surgical implant into the body, or (b) support or sustain life, or (c) whose failure to perform when properly used in accordance with instructions for use provided in the labeling, can be reasonably expected to result in significant injury to the user.
2. A critical component is any component of a life support device or system whose failure to perform can be reasonably expected to cause the failure of the life support device or system, or to affect its safety or effectiveness.

PRODUCT STATUS DEFINITIONS

Definition of Terms

Datasheet Identification	Product Status	Definition
Advance Information	Formative or In Design	This datasheet contains the design specifications for product development. Specifications may change in any manner without notice.
Preliminary	First Production	This datasheet contains preliminary data, and supplementary data will be published at a later date. Fairchild Semiconductor reserves the right to make changes at any time without notice in order to improve design.
No Identification Needed	Full Production	This datasheet contains final specifications. Fairchild Semiconductor reserves the right to make changes at any time without notice in order to improve design.
Obsolete	Not In Production	This datasheet contains specifications on a product that has been discontinued by Fairchild semiconductor. The datasheet is printed for reference information only.