

Fairchild's Offering

Fairchild's new series of logic gates, NC7SVL, reduces power consumption in mobile applications that require mixed voltage levels. Since undetected I_{CC} supply current may increase in these types of designs, there is a risk of increased power consumption as a result. Fairchild's NC7SVL logic gates eliminate hidden power consumption in mixed supply designs, enabling designers to stay within their power budgets and ensuring longer battery life.

Low I_{CC} Saves Power

In most ultra-portable applications today, there are multiple supply rails available and hidden power consumption can occur when input levels (V_{IH}) are lower than V_{CC} when using logic gates. Under these conditions, the quiescent I_{CC} current will increase as there is a path from V_{CC} to GND. This current is known as I_{CC} , as shown in Figure 1.

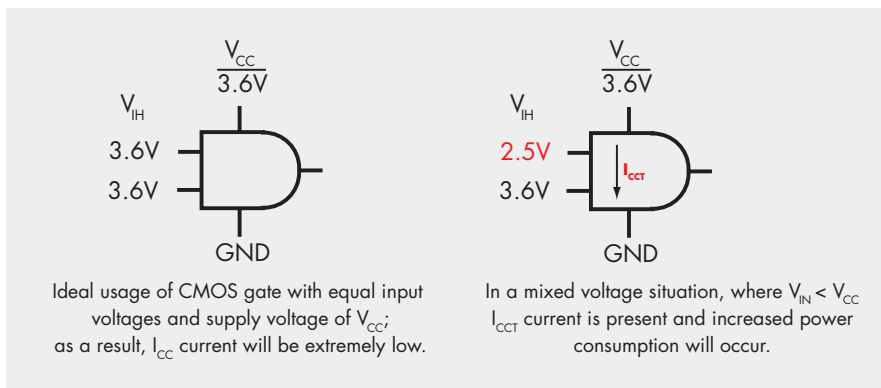

Figure 1

Fairchild Semiconductor's low I_{CC} gates are designed to change the input structure such that the threshold region is shifted to allow for a wider input voltage range without incurring an increase in I_{CC} current. Figure 2 below shows the effect of a redesigned input structure—the V_{IN} versus I_{CC} plot compares a standard CMOS input device with a low I_{CC} input design.

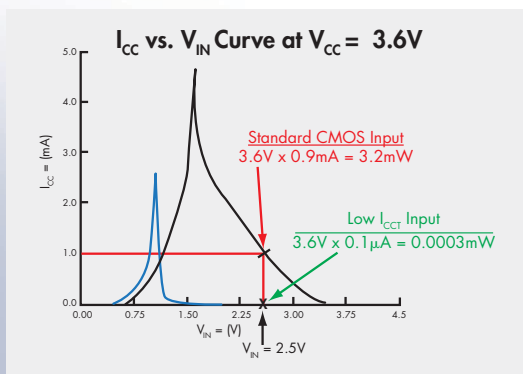
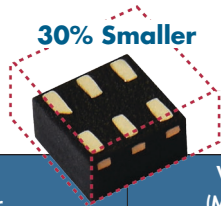

Figure 2

For data sheets, application notes, samples and more, please visit: www.fairchildsemi.com

Fairchild's NC7SVL low I_{CC} gates are now available. Custom designs may also be requested. Note that pin outs are standard; therefore, offer the user a direct drop-in replacement option for existing applications that would benefit from decreased power consumption.



Product Number	V _{CC} (Min.)	V _{CC} (Max.)	Output Characteristics	Number of Inputs	Package	Additional Features
NC7SVL04	-0.5	4.6	-0.5 to 4.5	1	MicroPAK2, MicroPak & SC70	Low I_{CC} for low power consumption
NC7SVL08	-0.5	4.6	-0.5 to 4.6	2	MicroPAK2, MicroPak & SC70	Low I_{CC} for low power consumption
NC7SVL32	-0.5	4.6	-0.5 to 4.6	2	MicroPAK2, MicroPak & SC70	Low I_{CC} for low power consumption



For additional information, please visit www.fairchildsemi.com/tinylogic