



FAN100

Primary-Side-Control PWM Controller

Features

- Constant-Voltage (CV) and Constant-Current (CC) Control without Secondary-Feedback Circuitry
- Accurate Constant Current Achieved by Fairchild's Proprietary *TRUECURRENT™* Technique
- Green Mode: Frequency Reduction at Light Load
- Fixed PWM Frequency at 42kHz with Frequency Hopping to Reduce EMI
- Low Startup Current: 10µA Maximum
- Low Operating Current: 3.5mA
- Peak-Current-Mode Control in CV Mode
- Cycle-by-Cycle Current Limiting
- Over-Temperature Protection with Auto-Restart
- Brownout Protection with Auto-Restart
- V_{DD} Over-Voltage Protection with Auto-Restart
- V_{DD} Under-Voltage Lockout (UVLO)
- Gate Output Maximum Voltage Clamped at 18V
- SOP-8 Package

Applications

- Battery Chargers for Cellular Phones, Cordless Phones, PDA, Digital Cameras, Power Tools
- Replaces Linear Transformer and RCC SMPS
- Offline High Brightness (HB) LED Drivers

Related Resources

- [AN-6067 — Design Guide for FAN100/102 and FSEZ1016A/1216](#)

Description

The primary-side PWM controller FAN100 significantly simplifies power supply design that requires CV and CC regulation capabilities. The FAN100 controls the output voltage and current precisely with the information in the primary side of the power supply, not only removing the output current sensing loss, but eliminating secondary feedback circuitry.

The green-mode function with a low startup current (10µA) maximizes the light-load efficiency so the power supply can meet stringent standby power regulations.

Compared with a conventional secondary-side regulation approach, the FAN100 can reduce total cost, component count, size, and weight; while simultaneously increasing efficiency, productivity, and system reliability.

FAN100 controller is available in an 8-pin SOP package.

A typical output CV/CC characteristic envelope is shown in Figure 1.

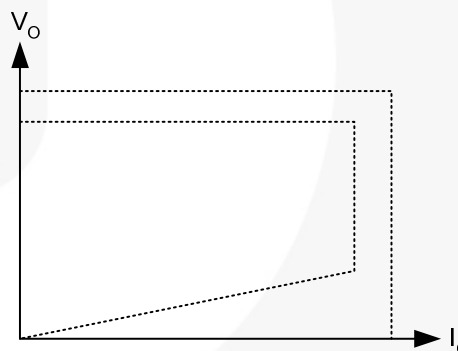



Figure 1. Typical Output V-I Characteristic

Ordering Information

Part Number	Operating Temperature Range	 Eco Status	Package	Packing Method
FAN100MY	-40°C to +125°C	Green	8-Lead, Small Outline Package (SOP-8)	Tape & Reel

 For Fairchild's definition of Eco Status, please visit: http://www.fairchildsemi.com/company/green/rohs_green.html.

Marking Information

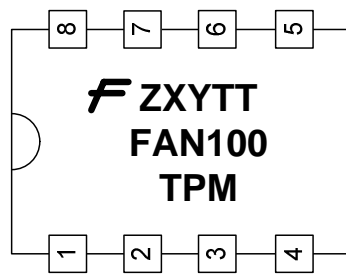

F- Fairchild logo
 Z- Plant Code
 X- 1-Digit Year Code
 Y- 1-Digit Week Code
 TT: 2-Digit Die Run Code
 T: Package Type (M=SOP)
 P: Z: Pb free, Y: Green Package
 M: Manufacture Flow Code

Figure 4. Top Mark

Pin Configuration

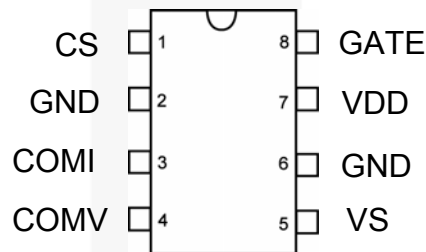

Figure 5. Pin Configuration

Pin Definitions

Pin #	Name	Description
1	CS	Current Sense. This pin connects a current-sense resistor to sense the MOSFET current for peak-current-mode control in CV mode and provides for output-current regulation in CC mode.
2	GND	Ground.
3	COMI	Constant Current Loop Compensation. this pin connects a capacitor and a resistor between COMI and GND for compensation current loop gain.
4	COMV	Constant Voltage Loop Compensation. this pin connects a capacitor and a resistor between COMV and GND for compensation voltage loop gain.
5	VS	Voltage Sense. This pin detects the output voltage information and discharge time based on voltage of auxiliary winding. This pin connects two divider resistors and one capacitor.
6	GND	Ground.
7	VDD	Supply. The power supply pin. IC operating current and MOSFET driving current are supplied using this pin. This pin is connected to an external V_{DD} capacitor of typically $10\mu\text{F}$. The threshold voltages for startup and turn-off are 16V and 5V, respectively. The operating current is lower than 5mA.
8	GATE	PWM Signal Output. This pin outputs PWM signal and includes the internal totem-pole output driver to drive the external power MOSFET. The clamped gate output voltage is 18V.

Absolute Maximum Ratings

Stresses exceeding the absolute maximum ratings may damage the device. The device may not function or be operable above the recommended operating conditions and stressing the parts to these levels is not recommended. In addition, extended exposure to stresses above the recommended operating conditions may affect device reliability. The absolute maximum ratings are stress ratings only.

Symbol	Parameter	Min.	Max.	Unit
V _{DD}	DC Supply Voltage ^(1,2)		30	V
V _{VS}	VS Pin Input Voltage	-0.3	7.0	V
V _{CS}	CS Pin Input Voltage	-0.3	7.0	V
V _{COMV}	Voltage Error Amplifier Output Voltage	-0.3	7.0	V
V _{COMI}	Voltage Error Amplifier Output Voltage	-0.3	7.0	V
P _D	Power Dissipation (T _A < 50°C)		660	mW
θ _{JA}	Thermal Resistance (Junction-to-Air)		150	°C/W
θ _{JC}	Thermal Resistance (Junction-to-Case)		39	°C/W
T _J	Operating Junction Temperature		+150	°C
T _{STG}	Storage Temperature Range	-55	+150	°C
T _L	Lead Temperature (Wave Soldering or IR, 10 Seconds)		+260	°C
ESD	Electrostatic Discharge Capability	Human Body Model, JEDEC: JESD22-A114	4.5	KV
		Charged Device Model, JEDEC: JESD22-C101	2.0	

Notes:

1. Stresses beyond those listed under Absolute Maximum Ratings may cause permanent damage to the device.
2. All voltage values, except differential voltages, are given with respect to GND pin.

Recommended Operating Conditions

The Recommended Operating Conditions table defines the conditions for actual device operation. Recommended operating conditions are specified to ensure optimal performance to the datasheet specifications. Fairchild does not recommend exceeding them or designing to Absolute Maximum Ratings.

Symbol	Parameter	Conditions	Min.	Typ.	Max.	Unit
T _A	Operating Ambient Temperature		-40		+125	°C

Electrical Characteristics

$V_{DD}=15V$ and $T_A=-40^{\circ}C\sim+125^{\circ}C$ ($T_A=T_J$), unless otherwise specified.

Symbol	Parameter	Conditions	Min.	Typ.	Max.	Units	
V_{DD} Section							
V _{OP}	Continuously Operating Voltage				25	V	
V _{DD-ON}	Turn-On Threshold Voltage		15	16	17	V	
V _{DD-OFF}	Turn-Off Threshold Voltage		4.5	5.0	5.5	V	
I _{DD-OP}	Operating Current	$V_{DD}=20V, f_s=f_{OSC}, V_{VS}=2V, V_{CS}=3V, C_L=1nF$		3.5	5.0	mA	
I _{DD-ST}	Startup Current	$0 < V_{DD} < V_{DD-ON}-0.16V$		3.7	10.0	μA	
I _{DD-GREEN}	Green Mode Operating Supply Current	$V_{DD}=20V, V_{VS}=2.7V, f_s=f_{OSC-N-MIN}, V_{CS}=0V, C_L=1nF, V_{COMV}=0V$		1.0	2.5	mA	
V _{DD-OVP}	V _{DD} Over-Voltage Protection Level	$V_{CS}=3V, V_{VS}=2.3V$	27	28	29	V	
t _{D-VDDOVP}	V _{DD} Over-Voltage Protection Debounce Time	$f_s=f_{OSC}, V_{VS}=2.3V$	100	250	400	μs	
Oscillator Section							
f _{OSC}	Frequency	Center Frequency	$T_A=25^{\circ}C$	39.0	42.0	45.0	KHz
		Frequency Hopping Range	$T_A=25^{\circ}C$	±1.8	±2.6	±3.6	
t _{FHR}	Frequency Hopping Period	$T_A=25^{\circ}C$		3		ms	
f _{OSC-N-MIN}	Minimum Frequency at No Load	$V_{VS}=2.7V, V_{COMV}=0V$		550		Hz	
f _{OSC-CM-MIN}	Minimum Frequency at CCM	$V_{VS}=2.3V, V_{CS}=0.5V$		20		KHz	
f _{DV}	Frequency Variation vs. V _{DD} Deviation	$T_A=25^{\circ}C, V_{DD}=10V$ to 25V			5	%	
f _{DT}	Frequency Variation vs. Temperature Deviation	$T_A=-40^{\circ}C$ to 125°C			20	%	
Voltage-Sense Section							
I _{VS-UVP}	Sink Current for Brownout Protection	$R_{VS}=20K\Omega$		180		μA	
I _{tc}	IC Compensation Bias Current			9.5		μA	
V _{BIAS-COMV}	Adaptive Bias Voltage Dominated by V _{COMV}	$V_{COMV}=0V, T_A=25^{\circ}C, R_{VS}=20K\Omega$		1.4		V	
Current-Sense Section							
t _{PD}	Propagation Delay to GATE Output			100	200	ns	
t _{MIN-N}	Minimum On Time at No Load	$V_{VS}=-0.8V, R_S=2K\Omega, V_{COMV}=1V$		1100		ns	
t _{MINCC}	Minimum On Time in CC Mode	$V_{VS}=0V, V_{COMV}=2V$		300		ns	
V _{TH}	Threshold Voltage for Current Limit			1.3		V	

Continued on following page...

Electrical Characteristics (Continued)

$V_{DD}=15V$ and $T_A=-40^{\circ}C\sim+125^{\circ}C$ ($T_A=T_J$), unless otherwise specified.

Symbol	Parameter	Conditions	Min.	Typ.	Max.	Units
Voltage-Error-Amplifier Section						
V_{VR}	Reference Voltage		2.475	2.500	2.525	V
V_N	Green Mode Starting Voltage on COMV Pin	$f_S=f_{OSC}=2KHz$ $V_{VS}=2.3V$		2.8		V
V_G	Green Mode Ending Voltage on COMV Pin	$f_S=1KHz$		0.8		V
I_{V-SINK}	Output Sink Current	$V_{VS}=3V, V_{COMV}=2.5V$		90		μA
$I_{V-SOURCE}$	Output Source Current	$V_{VS}=2V, V_{COMV}=2.5V$		90		μA
V_{V-HGH}	Output High Voltage	$V_{VS}=2.3V$	4.5			V
Current-Error-Amplifier Section						
V_{IR}	Reference Voltage		2.475	2.500	2.525	V
I_{I-SINK}	Output Sink Current	$V_{CS}=3V, V_{COMI}=2.5V$		55		μA
$I_{I-SOURCE}$	Output Source Current	$V_{CS}=0V, V_{COMI}=2.5V$		55		μA
V_{I-HGH}	Output High Voltage	$V_{CS}=0V$	4.5			V
Gate Section						
DCY_{MAX}	Maximum Duty Cycle			75		%
V_{OL}	Output Voltage Low	$V_{DD}=20V, I_O=10mA$			1.5	V
V_{OH}	Output Voltage High	$V_{DD}=8V, I_O=1mA$	5			V
V_{OH_MIN}	Output Voltage High	$V_{DD}=5.5V, I_O=1mA$	4			V
t_r	Rising Time	$V_{DD}=20V, C_L=1nF$		200	300	ns
t_f	Falling Time	$V_{DD}=20V, C_L=1nF$		80	150	ns
V_{CLAMP}	Output Clamp Voltage	$V_{DD}=25V$		15	18	V
Over-Temperature-Protection Section						
T_{OTP}	Threshold Temperature for OTP			+140		$^{\circ}C$

Typical Performance Characteristics

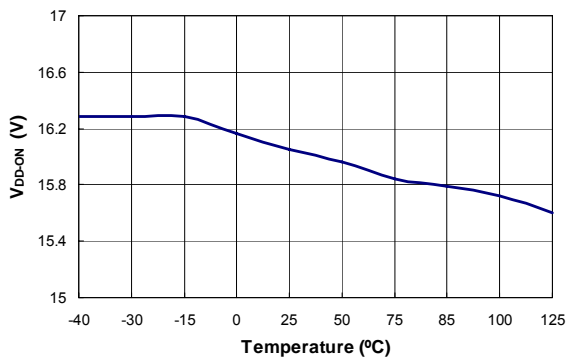

Figure 6. Turn-On Threshold Voltage (V_{DD-ON}) vs. Temperature

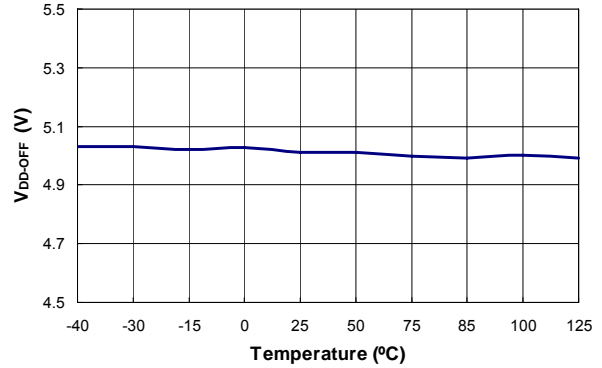

Figure 7. Turn-Off Threshold Voltage (V_{DD-OFF}) vs. Temperature

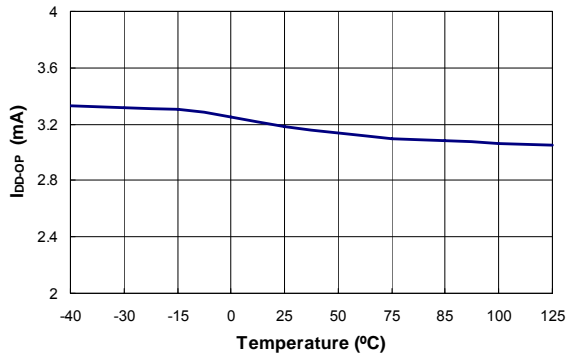

Figure 8. Operating Current (I_{DD-OP}) vs. Temperature

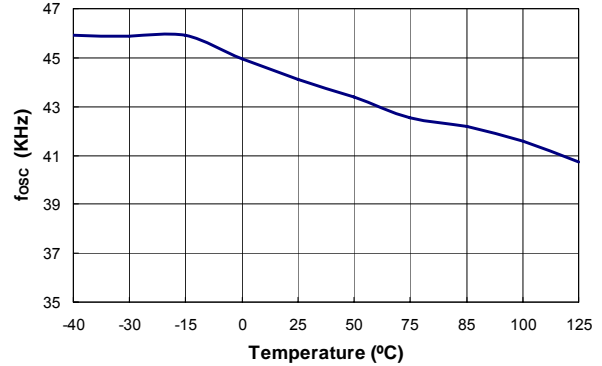

Figure 9. Center Frequency (f_{osc}) vs. Temperature

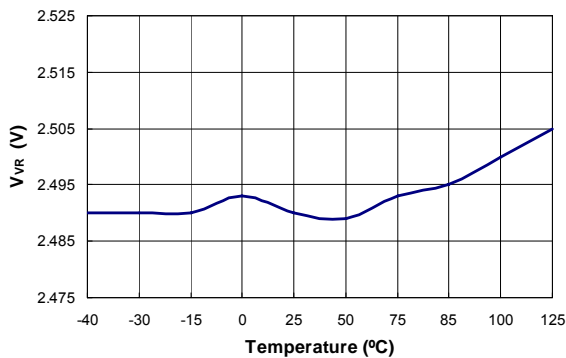

Figure 10. Reference Voltage (V_{VR}) vs. Temperature

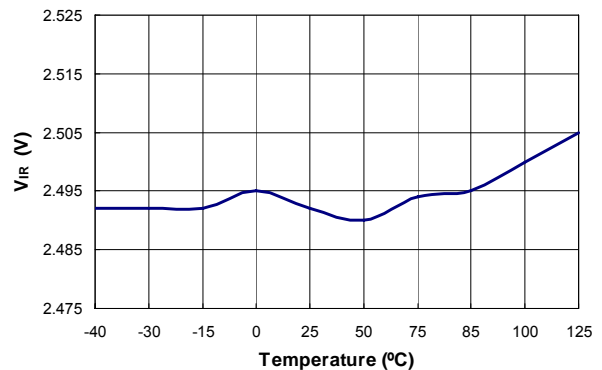

Figure 11. Reference Voltage (V_{IR}) vs. Temperature

Typical Performance Characteristics

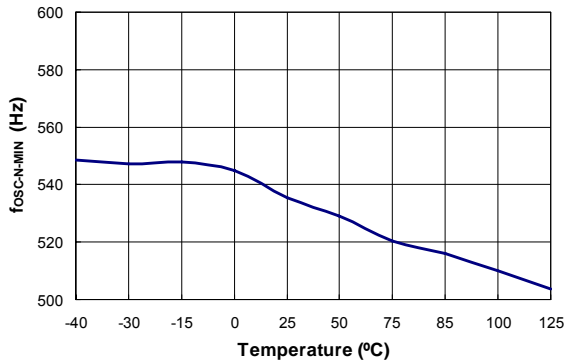

Figure 12. Minimum Frequency at No Load (f_{OSC-N-MIN}) vs. Temperature

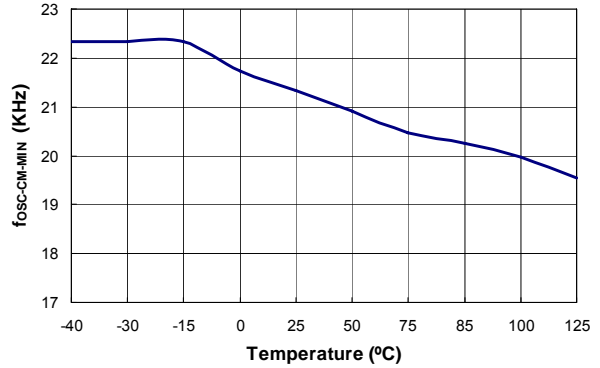

Figure 13. Minimum Frequency at CCM (f_{OSC-CM-MIN}) vs. Temperature

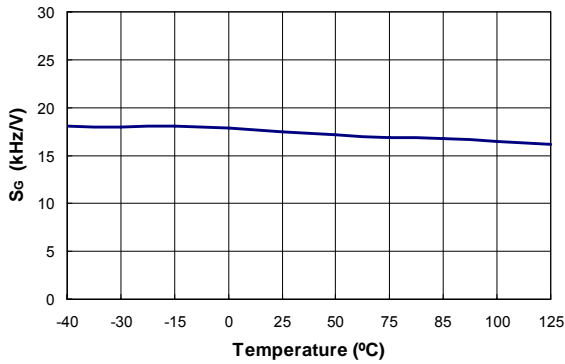

Figure 14. Green Mode Frequency Decreasing Rate (S_G) vs. Temperature

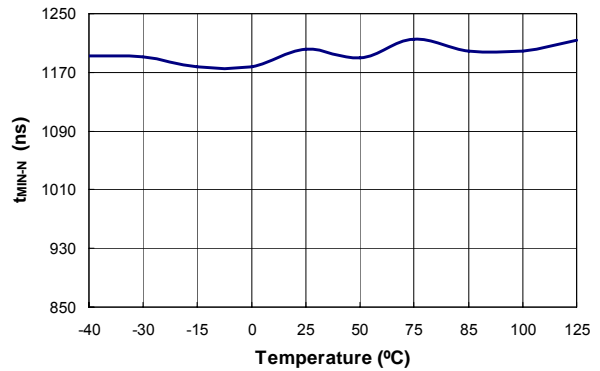

Figure 15. Minimum On Time at No Load (t_{MIN-N}) vs. Temperature

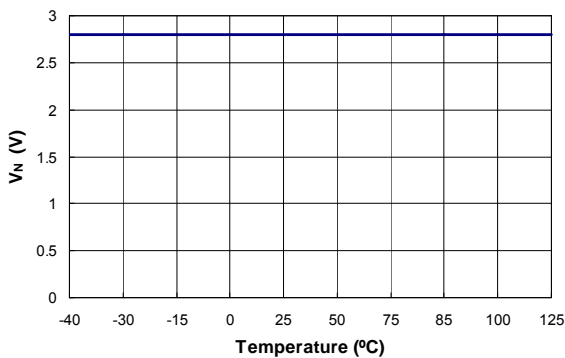

Figure 16. Green Mode Starting Voltage on COMV Pin (V_N) vs. Temperature

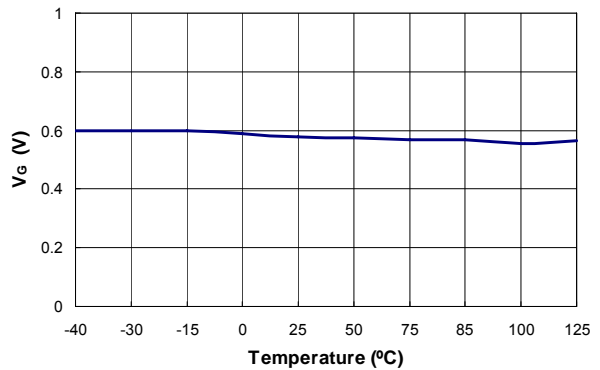

Figure 17. Green Mode Ending Voltage on COMV Pin (V_G) vs. Temperature

Typical Performance Characteristics

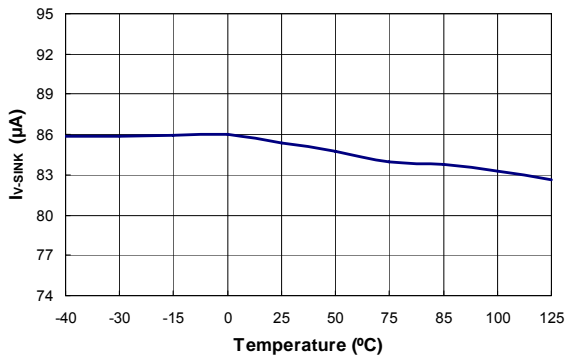

Figure 18. Output Sink Current (I_{V-SINK}) vs. Temperature

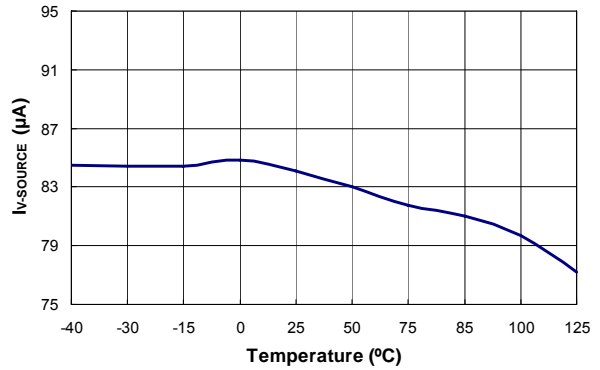

Figure 19. Output Source Current ($I_{V-SOURCE}$) vs. Temperature

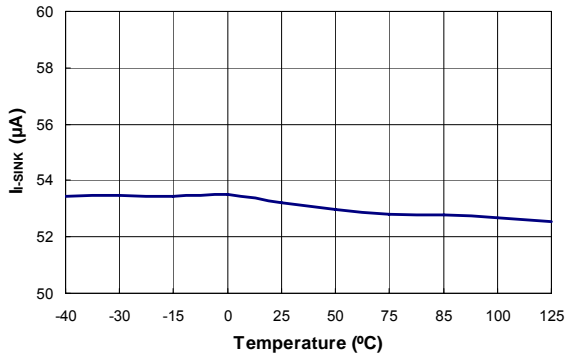

Figure 20. Output Sink Current (I_{I-SINK}) vs. Temperature

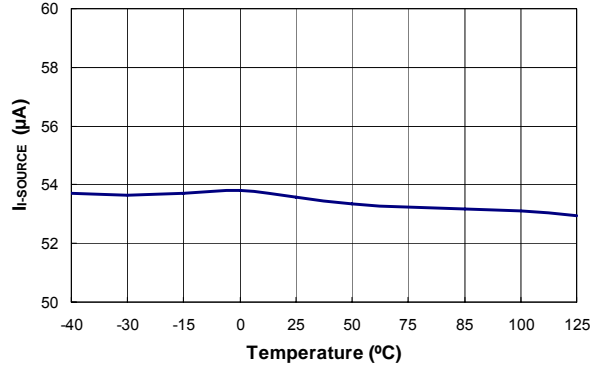

Figure 21. Output Source Current ($I_{I-SOURCE}$) vs. Temperature

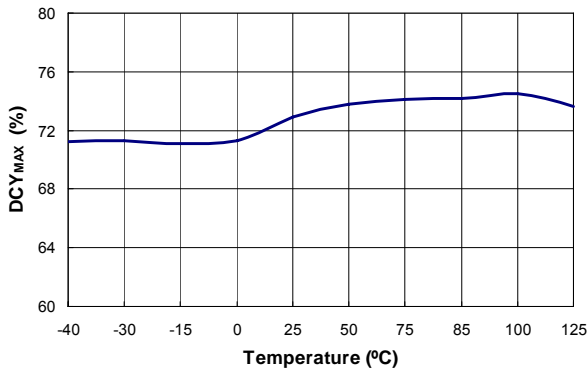

Figure 22. Maximum Duty Cycle (DCY_{MAX}) vs. Temperature

Functional Description

0 shows the basic circuit diagram of a primary-side regulated flyback converter and its typical waveforms are shown in 0. Generally, discontinuous conduction mode (DCM) operation is preferred for primary-side regulation since it allows better output regulation. The operation principles of DCM flyback converter are as follows:

During the MOSFET on time (t_{ON}), input voltage (V_{DL}) is applied across the primary side inductor (L_m). Then, MOSFET current (I_{ds}) increases linearly from zero to the peak value (I_{pk}). During this time, the energy is drawn from the input and stored in the inductor.

When the MOSFET is turned off, the energy stored in the inductor forces the rectifier diode (D) to be turned on. While the diode is conducting, the output voltage (V_o), together with diode forward-voltage drop (V_F), is applied across the secondary-side inductor ($L_m \times N_s^2 / N_p^2$) and the diode current (I_D) decreases linearly from the peak value ($I_{pk} \times N_p / N_s$) to zero. At the end of inductor current discharge time (t_{DIS}), all the energy stored in the inductor has been delivered to the output.

When the diode current reaches zero, the transformer auxiliary winding voltage (V_w) begins to oscillate by the resonance between the primary-side inductor (L_m) and the effective capacitor loaded across the MOSFET.

During the inductor current discharge time, the sum of output voltage and diode forward-voltage drop is reflected to the auxiliary winding side as $(V_o + V_F) \times N_a / N_s$. Since the diode forward-voltage drop decreases as current decreases, the auxiliary winding voltage reflects the output voltage best at the end of diode conduction time where the diode current diminishes to zero. Thus, by sampling the winding voltage at the end of the diode conduction time, the output voltage information can be obtained. The internal error amplifier for output voltage regulation (EA_V) compares the sampled voltage with internal precise reference to generate error voltage (V_{COMV}), which determines the duty cycle of the MOSFET in CV mode.

Meanwhile, the output current can be estimated using the peak drain current and inductor current discharge time since output current is the same as average of the diode current in steady state.

The output current estimator detects the peak value of the drain current with a peak detection circuit and calculates the output current using the inductor discharge time (t_{DIS}) and switching period (t_s). This output information is compared with the internal precise reference to generate error voltage (V_{COMI}), which determines the duty cycle of the MOSFET in CC mode. With Fairchild's innovative technique, TRUECURRENT™, constant current (CC) output can be precisely controlled.

Of the two error voltages, V_{COMV} and V_{COMI} , the smaller determines the duty cycle. During constant voltage regulation mode, V_{COMV} determines the duty cycle while V_{COMI} is saturated to HIGH. During constant current regulation mode, V_{COMI} determines the duty cycle while V_{COMV} is saturated to HIGH.

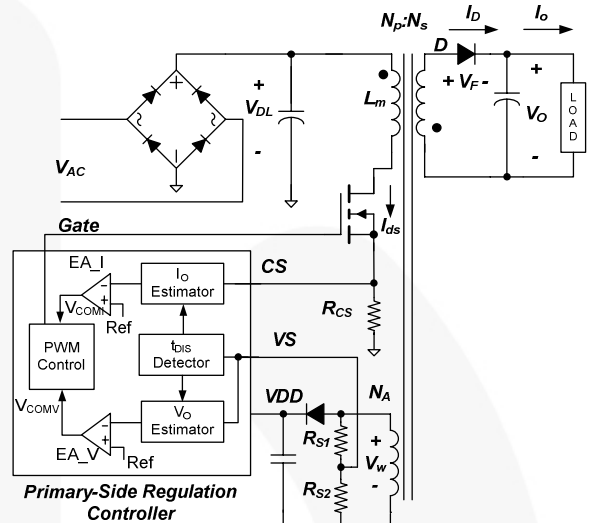

Figure 23. Simplified PSR Flyback Converter Circuit

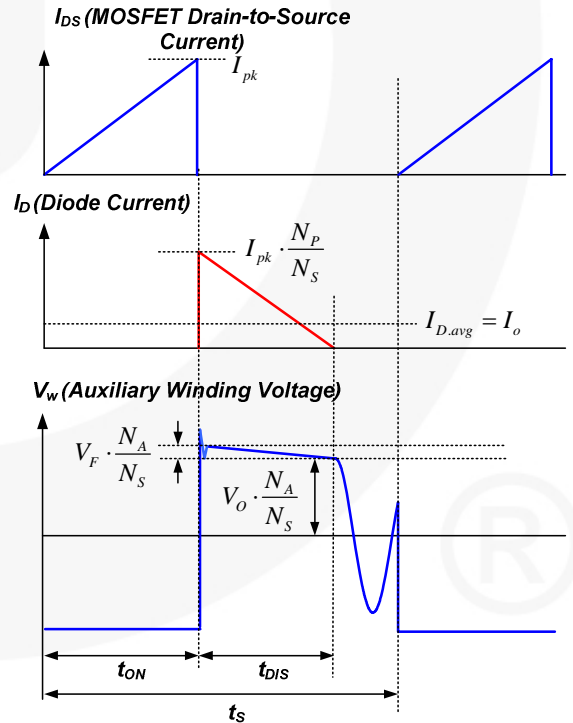

Figure 24. Key Waveforms of DCM Flyback Converter

Temperature Compensation

Built-in temperature compensation provides constant voltage regulation over a wide range of temperature variation. This internal compensation current compensates the forward-voltage drop variation of the secondary side rectifier diode.

Green-Mode Operation

The FAN100 uses voltage regulation error amplifier output (V_{COMV}) as an indicator of the output load and modulates the PWM frequency as shown in Figure 25 such that the switching frequency decreases as load decreases. In heavy-load conditions, the switching frequency is fixed at 42kHz. Once V_{COMV} decreases below 2.8V, the PWM frequency starts to linearly decrease from 42kHz to 550Hz to reduce the switching losses. As V_{COMV} decreases below 0.8V, the switching frequency is fixed at 550Hz and FAN100 enters into “deep green” mode, where the operating current reduces to 1mA, reducing the standby power consumption.

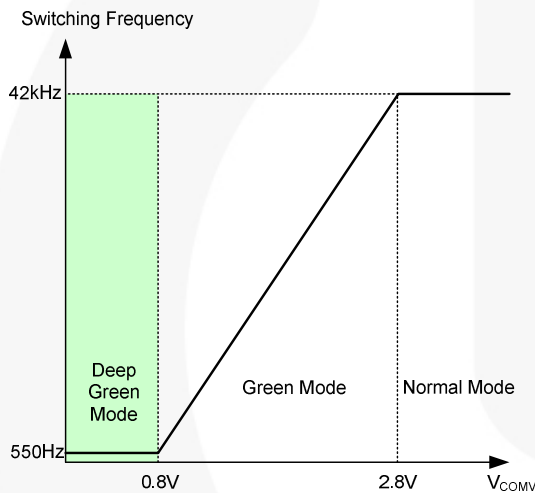

Figure 25. Switching Frequency in Green Mode

Leading-Edge Blanking (LEB)

At the instant the MOSFET is turned on, a high-current spike occurs through the MOSFET, caused by primary-side capacitance and secondary-side rectifier reverse recovery. Excessive voltage across the R_{CS} resistor can lead to premature turn-off of the MOSFET. FAN100 employs an internal leading edge blanking (LEB) circuit to inhibit the PWM comparator for a short time after the MOSFET turns on. External RC filtering is not required.

Frequency Hopping

EMI reduction is accomplished by frequency hopping, which spreads the energy over a wider frequency range than the bandwidth measured by the EMI test equipment. FAN100 has an internal frequency-hopping circuit that changes the switching frequency between 39.4kHz and 44.6kHz with a period of 3ms, as shown in Figure 26.

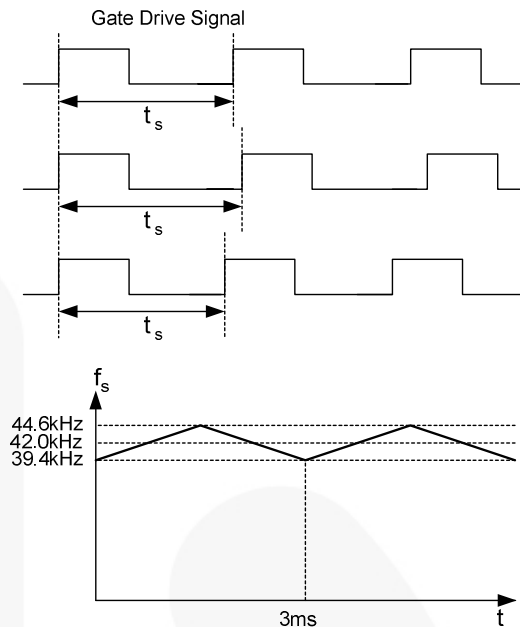

Figure 26. Frequency Hopping

Startup

Figure 27 shows the typical startup circuit and transformer auxiliary winding for FAN100 application. Before FAN100 begins switching, it consumes only startup current (maximum 10 μ A) and the current supplied through the startup resistor charges the V_{DD} capacitor (C_{DD}). When V_{DD} reaches turn-on voltage of 16V (V_{DD-ON}), FAN100 begins switching, and the current consumed increases to 3.5mA. Then, the power required for FAN100 is supplied from the transformer auxiliary winding. The large hysteresis of V_{DD} provides more hold-up time, which allows using small capacitor for V_{DD} .

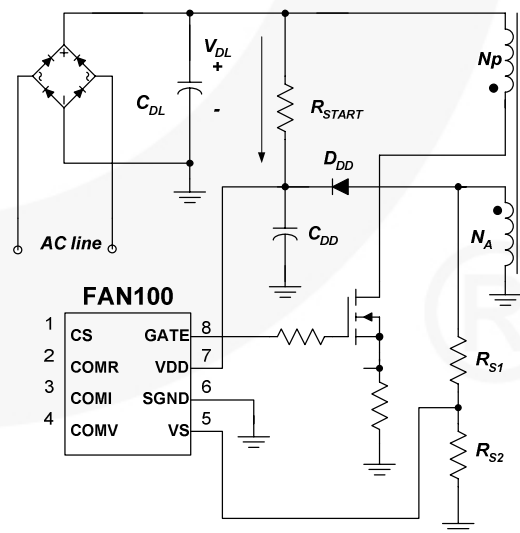

Figure 27. Startup Circuit

Protections

The FAN100 has several self-protective functions, such as Over-Voltage Protection (OVP), Over-Temperature Protection (OTP), and brownout protection. All the protections are implemented as auto-restart mode. When auto-restart protection is triggered, switching is terminated and the MOSFET remains off. This causes V_{DD} to fall. When V_{DD} reaches the V_{DD} turn-off voltage of 5V, the current consumed by FAN100 reduces to the startup current (maximum 10 μ A) and the current supplied startup resistor charges the V_{DD} capacitor. When V_{DD} reaches the turn-on voltage of 16V, FAN100 resumes normal operation. In this manner, the auto-restart alternately enables and disables the switching of the MOSFET until the fault condition is eliminated (see Figure 28).

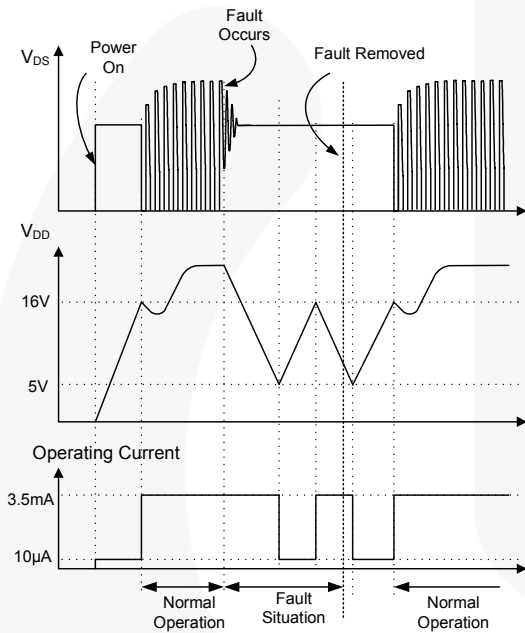

Figure 28. Auto-Restart Operation

V_{DD} Over-Voltage Protection (OVP)

V_{DD} over-voltage protection prevents damage from over-voltage conditions. If the V_{DD} voltage exceeds 28V by open-feedback condition, OVP is triggered. The OVP has a debounce time (typical 250 μ s) to prevent false triggering by switching noise. It also protects other switching devices from over voltage.

Over-Temperature Protection (OTP)

The built-in temperature-sensing circuit shuts down PWM output if the junction temperature exceeds 140°C.

Brownout Protection

FAN100 detects the line voltage using auxiliary winding voltage since the auxiliary winding voltage reflects the input voltage when the MOSFET is turned on. VS pin is clamped at 1.15V while the MOSFET is turned on and brownout protection is triggered if the current out of VS pin is less than I_{VS-UVP} (typical 180 μ A) during the MOSFET conduction.

Pulse-by-pulse Current Limit

When the sensing voltage across the current sense resistor exceeds the internal threshold of 1.3V, the MOSFET is turned off for the remainder of the switching cycle. In normal operation, the pulse-by-pulse current limit is not triggered since the peak current is limited by the control loop.

Typical Application Circuit (Primary-Side Regulated Offline LED Driver)

Application	Fairchild Devices	Input Voltage Range	Output
Offline LED Driver	FAN100	90~265V _{AC}	24V/0.35A (8.4W)

Features

- High Efficiency (>77% at Full Load)
- Tight Output Regulation (CC:±5%)

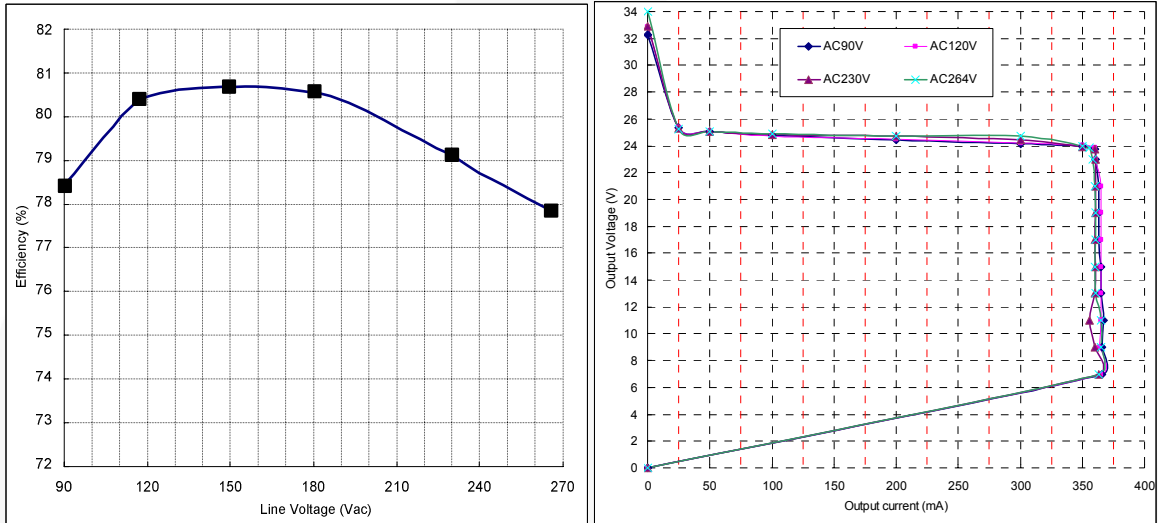

Figure 29. Measured Efficiency and Output Regulation

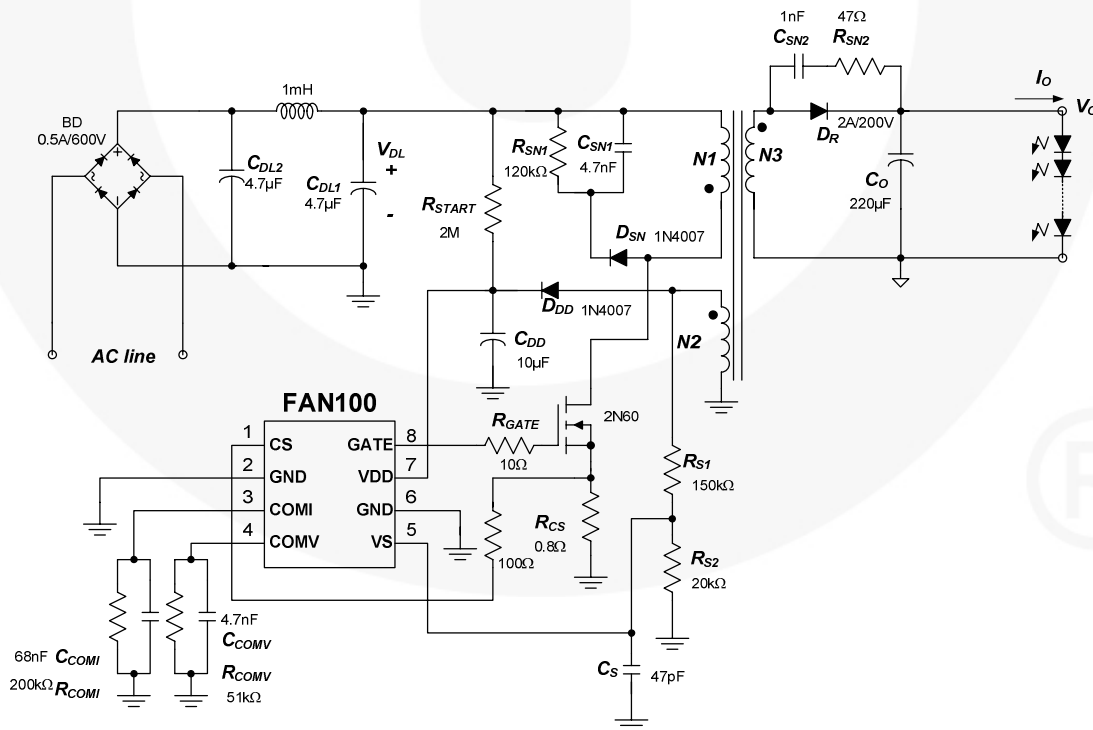
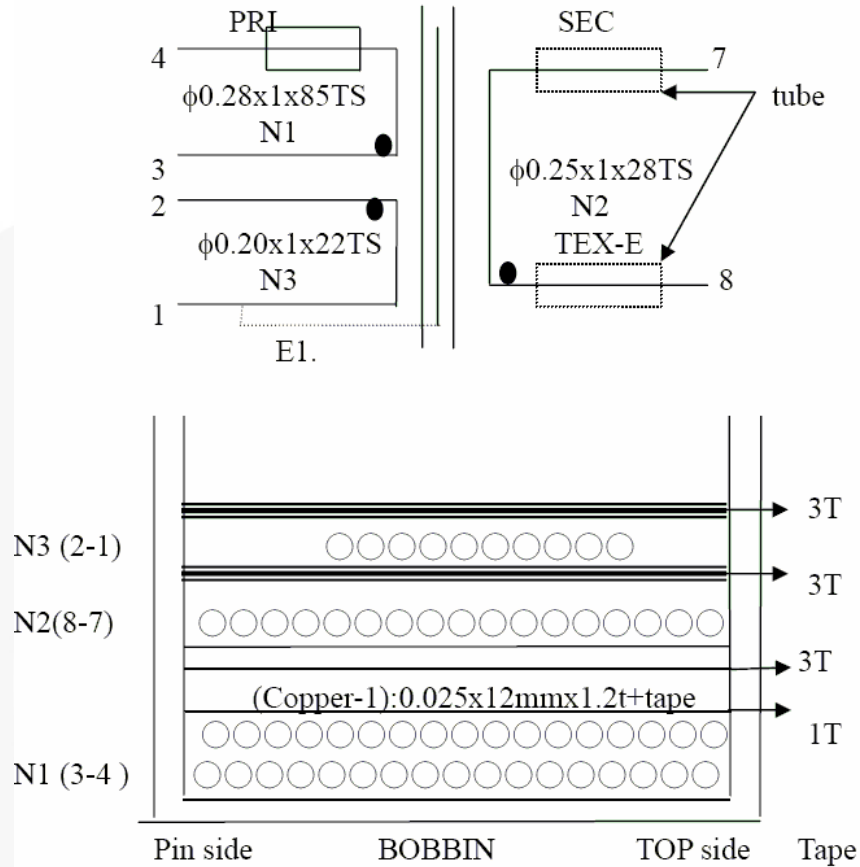

Figure 30. Typical Application Circuit Schematic

Typical Application Circuit (Continued)

Transformer Specification

- Core: EFD-20
- Bobbin: EFD-20



	Pin	Specification	Remark
Primary-Side Inductance	3 – 4	1.08mH ± 5%	100kHz, 1V
Primary-Side Effective Leakage	3 – 4	35μH ± 5%.	Short one of the secondary windings

Physical Dimensions

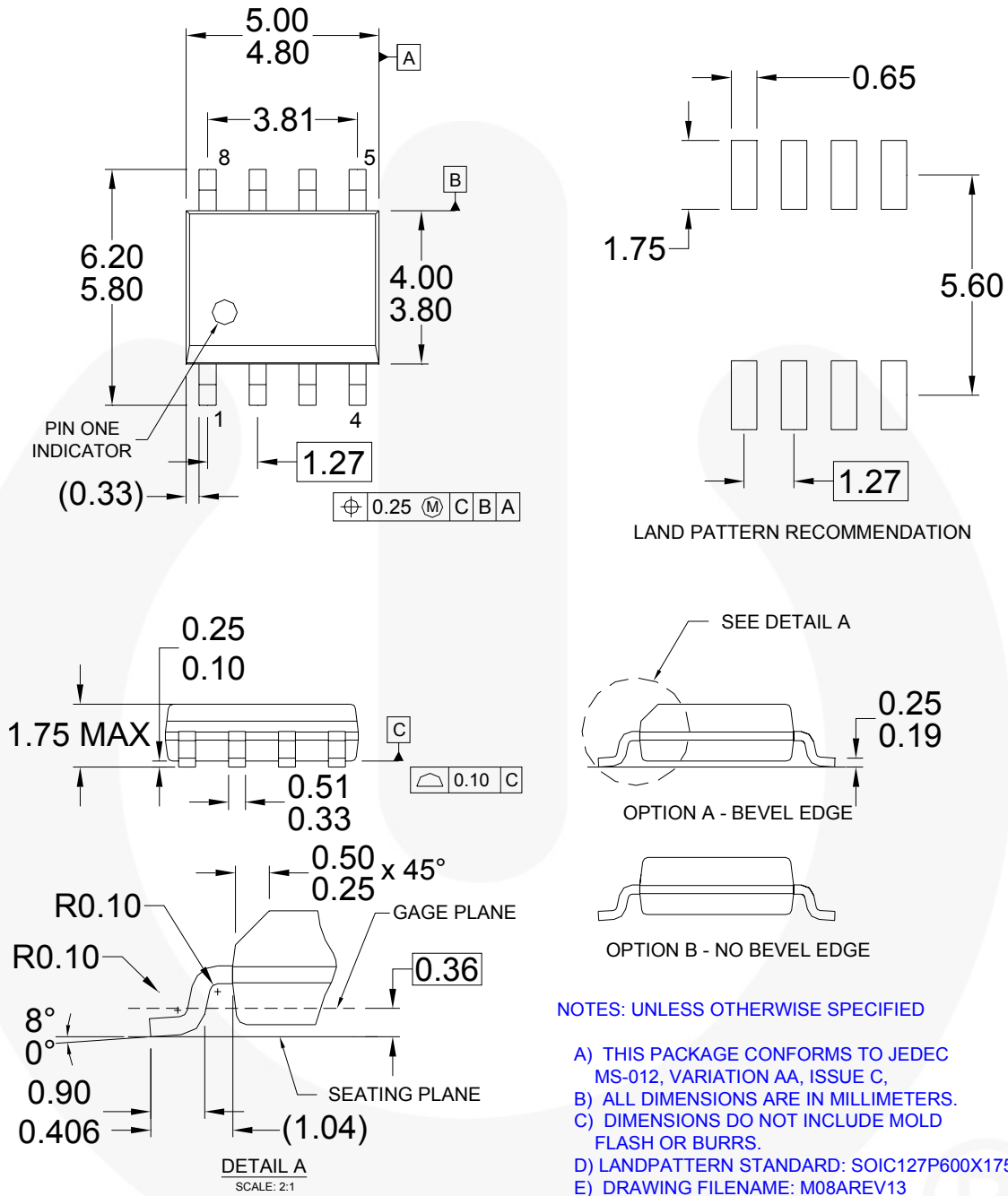

Figure 31. 8-Lead, Small Outline Package (SOP-8)







Package drawings are provided as a service to customers considering Fairchild components. Drawings may change in any manner without notice. Please note the revision and/or date on the drawing and contact a Fairchild Semiconductor representative to verify or obtain the most recent revision. Package specifications do not expand the terms of Fairchild's worldwide terms and conditions, specifically the warranty therein, which covers Fairchild products.

Always visit Fairchild Semiconductor's online packaging area for the most recent package drawings:
<http://www.fairchildsemi.com/packaging/>



TRADEMARKS

The following includes registered and unregistered trademarks and service marks, owned by Fairchild Semiconductor and/or its global subsidiaries, and is not intended to be an exhaustive list of all such trademarks.

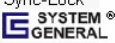
- | | | | |
|---|---|---|---|
| Auto-SPM™ | F-PFST™ | PowerTrench® | The Power Franchise® |
| Build it Now™ | FRFET® | PowerXS™ |  |
| CorePLUS™ | Global Power Resource™ | Programmable Active Droop™ | TinyBoost™ |
| CorePOWER™ | Green FPS™ | QFET® | TinyBuck™ |
| CROSSVOLT™ | Green FPS™ e-Series™ | QS™ | TinyLogic® |
| CTL™ | Gmax™ | Quiet Series™ | TINYOPTO™ |
| Current Transfer Logic™ | GTO™ | RapidConfigure™ | TinyPower™ |
| EcoSPARK® | IntelliMAX™ |  | TinyPWM™ |
| EfficientMax™ | ISOPLANAR™ | Saving our world, 1mW/W/kW at a time™ | TinyWire™ |
| EZSWITCH™ | MegaBuck™ | SmartMax™ | TriFault Detect™ |
|  | MICROCOUPLER™ | SMART START™ | TRUECURRENT™ |
|  | MicroFET™ | SPM® | µSerDes™ |
| Fairchild® | MicroPak™ | STEALTH™ |  |
| Fairchild Semiconductor® | MillerDrive™ | SuperFET™ | UHC® |
| FACT Quiet Series™ | MotionMax™ | SuperSOT™.3 | Ultra FRFET™ |
| FACT® | Motion-SPM™ | SuperSOT™.8 | UniFET™ |
| FACT® | OPTOLOGIC® | SuperSOT™.8 | VCX™ |
| FAST® | OPTOPLANAR® | SupreMOS™ | VisualMax™ |
| FastvCore™ |  | SyncFET™ | XST™ |
| FETBench™ | PDP SPM™ | Sync-Lock™ | |
| FlashWriter® | Power-SPM™ |  | |
| FPST™ | | | |

* Trademarks of System General Corporation, used under license by Fairchild Semiconductor.

DISCLAIMER

FAIRCHILD SEMICONDUCTOR RESERVES THE RIGHT TO MAKE CHANGES WITHOUT FURTHER NOTICE TO ANY PRODUCTS HEREIN TO IMPROVE RELIABILITY, FUNCTION, OR DESIGN. FAIRCHILD DOES NOT ASSUME ANY LIABILITY ARISING OUT OF THE APPLICATION OR USE OF ANY PRODUCT OR CIRCUIT DESCRIBED HEREIN; NEITHER DOES IT CONVEY ANY LICENSE UNDER ITS PATENT RIGHTS, NOR THE RIGHTS OF OTHERS. THESE SPECIFICATIONS DO NOT EXPAND THE TERMS OF FAIRCHILD'S WORLDWIDE TERMS AND CONDITIONS, SPECIFICALLY THE WARRANTY THEREIN, WHICH COVERS THESE PRODUCTS.

LIFE SUPPORT POLICY

FAIRCHILD'S PRODUCTS ARE NOT AUTHORIZED FOR USE AS CRITICAL COMPONENTS IN LIFE SUPPORT DEVICES OR SYSTEMS WITHOUT THE EXPRESS WRITTEN APPROVAL OF FAIRCHILD SEMICONDUCTOR CORPORATION.

As used herein:

1. Life support devices or systems are devices or systems which, (a) are intended for surgical implant into the body or (b) support or sustain life, and (c) whose failure to perform when properly used in accordance with instructions for use provided in the labeling, can be reasonably expected to result in a significant injury of the user.
2. A critical component in any component of a life support, device, or system whose failure to perform can be reasonably expected to cause the failure of the life support device or system, or to affect its safety or effectiveness.

ANTI-COUNTERFEITING POLICY

Fairchild Semiconductor Corporation's Anti-Counterfeiting Policy. Fairchild's Anti-Counterfeiting Policy is also stated on our external website, www.fairchildsemi.com, under Sales Support.

Counterfeiting of semiconductor parts is a growing problem in the industry. All manufacturers of semiconductor products are experiencing counterfeiting of their parts. Customers who inadvertently purchase counterfeit parts experience many problems such as loss of brand reputation, substandard performance, failed applications, and increased cost of production and manufacturing delays. Fairchild is taking strong measures to protect ourselves and our customers from the proliferation of counterfeit parts. Fairchild strongly encourages customers to purchase Fairchild parts either directly from Fairchild or from Authorized Fairchild Distributors who are listed by country on our web page cited above. Products customers buy either from Fairchild directly or from Authorized Fairchild Distributors are genuine parts, have full traceability, meet Fairchild's quality standards for handling and storage and provide access to Fairchild's full range of up-to-date technical and product information. Fairchild and our Authorized Distributors will stand behind all warranties and will appropriately address any warranty issues that may arise. Fairchild will not provide any warranty coverage or other assistance for parts bought from Unauthorized Sources. Fairchild is committed to combat this global problem and encourage our customers to do their part in stopping this practice by buying direct or from authorized distributors.

PRODUCT STATUS DEFINITIONS

Definition of Terms

Datasheet Identification	Product Status	Definition
Advance Information	Formative / In Design	Datasheet contains the design specifications for product development. Specifications may change in any manner without notice.
Preliminary	First Production	Datasheet contains preliminary data; supplementary data will be published at a later date. Fairchild Semiconductor reserves the right to make changes at any time without notice to improve design.
No Identification Needed	Full Production	Datasheet contains final specifications. Fairchild Semiconductor reserves the right to make changes at any time without notice to improve the design.
Obsolete	Not In Production	Datasheet contains specifications on a product that is discontinued by Fairchild Semiconductor. The datasheet is for reference information only.

Rev. I40