

FSA1256(A) / FSA1257(A) / FSA1258(A)

Low- R_{ON} Low-Voltage, Dual SPDT Analog Switch with Low- I_{CCT} “A” Option

Features

- FSA1256A, FSA1257A, FSA1258A Feature Low I_{CCT} when S Input is Lower than V_{CC}
- Maximum 1.1 Ω On Resistance (R_{ON}) for 4.5V Supply
- 0.4 Ω max R_{ON} Flatness for 4.5V Supply
- Space-Saving Pb-Free MicroPak™ Packaging
- Broad V_{CC} Operating Range:
 - FSA1256, FSA1257, FSA1258: 1.65V to 5.5V
 - FSA1256A, FSA1257A, FSA1258A: 2.7V to 5.5V
- Fast Turn-On and Turn-Off Times
- FSA1258, FSA1258A Feature Break-Before-Make Enable Circuitry
- Over-Voltage Tolerant TTL-Compatible Control Input

Applications

- Cell Phone, PDA, Digital Camera, and Notebook
- LCD Monitor, TV, and Set-Top Box

Description

The FSA1256, FSA1256A, FSA1257, FSA1257A, FSA1258, and FSA1258A are high performance dual Single-Pole / Single-Throw (SPST) analog switches. All devices feature ultra-low R_{ON} of 1.1 Ω maximum at 4.5V V_{CC} . The FSA1256, FSA1257, and FSA1258 operate over a wide V_{CC} range of 1.65V to 5.5V. The FSA1256A, FSA1257A, and FSA1258A operation range is 2.7V to 5.5V. These devices are fabricated with sub-micron CMOS technology to achieve fast switching speeds and are designed for break-before-make operation. The select input is TTL level compatible. The FSA1256 and FSA1256A feature two Normally Open (NO) switches. The FSA1257 and FSA1257A feature two Normally Closed (NC) switches. The FSA1258 and FSA1258A have one NO switch and one NC switch.

IMPORTANT NOTE:

For additional performance information, please contact analogswitch@fairchildsemi.com.

Ordering Information

Part Number	Top Mark	Package Description	Packing Method
FSA1256L8X	EB	8-Lead, MicroPak™, 1.6mm Wide	5000 Units Tape and Reel
FSA1256AL8X	FN	8-Lead, MicroPak™, 1.6mm Wide	5000 Units Tape and Reel
FSA1257L8X	EC	8-Lead, MicroPak™, 1.6mm Wide	5000 Units Tape and Reel
FSA1257AL8X	FP	8-Lead, MicroPak™, 1.6mm Wide	5000 Units Tape and Reel
FSA1258L8X	ED	8-Lead, MicroPak™, 1.6mm Wide	5000 Units Tape and Reel
FSA1258AL8X	FS	8-Lead, MicroPak™, 1.6mm Wide	5000 Units Tape and Reel

MicroPak™ is a trademark of Fairchild Semiconductor Corporation.

Analog Symbols

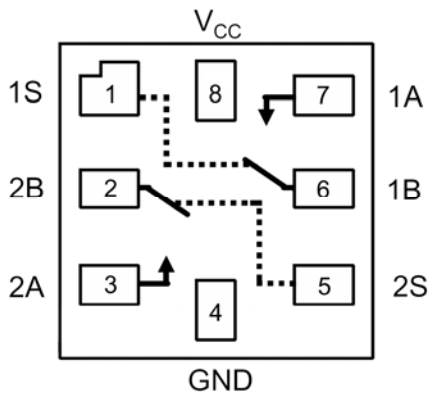

Figure 1. FSA1256, FSA1256A

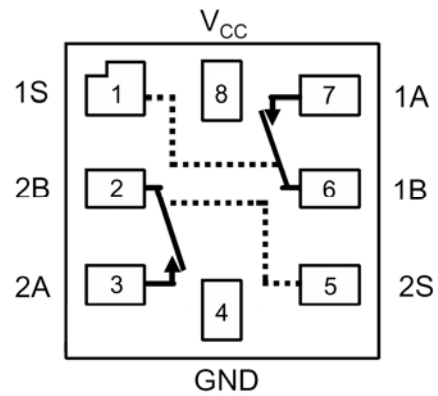

Figure 2. FSA1257, FSA1257A

Truth Tables

Control Input (s)	Function
LOW Logic Level	Disconnect
HIGH Logic Level	A Connected to B

Control Input (s)	Function
LOW Logic Level	A Connected to B
HIGH Logic Level	Disconnected

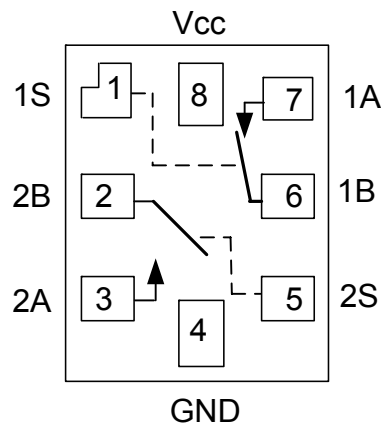

Figure 3. FSA1258, FSA1258A

Truth Table

Control Input, 1S	Function	Control Input 2S	Function
LOW Logic Level	1A Connected to 1 B	LOW Logic Level	Disconnect
HIGH Logic Level	Disconnect	HIGH Logic Level	2A Connected to 2B

Pin Descriptions

Name	Description
A, B ₀ , B ₁	Data Ports
S	Switch Select Pin

Absolute Maximum Ratings

Stresses exceeding the absolute maximum ratings may damage the device. The device may not function or be operable above the recommended operating conditions and stressing the parts to these levels is not recommended. In addition, extended exposure to stresses above the recommended operating conditions may affect device reliability. The absolute maximum ratings are stress ratings only.

Symbol	Parameter	Min.	Max.	Units
V _{CC}	Supply Voltage	-0.5	6.0	V
V _S	Switch Voltage ⁽¹⁾	-0.5	V _{CC} +0.5	V
V _{in}	Input Voltage ⁽¹⁾	-0.5	6.0	V
	Power Dissipation at 85°C, MicroPak™ 8L Package		180	mW
I _{IK}	Input Diode Current		-50	mA
I _{SW}	Switch Current		200	mA
I _{SWPEAK}	Peak Switch Current (Pulsed at 1ms Duration, <10% Duty Cycle)		400	mA
T _{STG}	Storage Temperature Range	-65	+150	°C
T _J	Maximum Junction Temperature		+150	°C
T _L	Lead Temperature (Soldering 10 Seconds)		+260	°C
ESD	Human Body Model (JEDEC: JESD22-A114)	FSA1256, FSA1257, FSA1258	5.5	kV
		FSA1256A, FSA1257A, FSA1258A	4.5	

Note:

1. Input and output negative ratings may be exceeded if input and output diode current ratings are observed.

Recommended Operating Conditions

The Recommended Operating Conditions table defines the conditions for actual device operation. Recommended operating conditions are specified to ensure optimal performance to the datasheet specifications. Fairchild does not recommend exceeding them or designing to absolute maximum ratings.

Symbol	Parameter	Min.	Max.	Units	
V _{CC}	Supply Voltage	FSA1256, FSA1257, FSA1258	1.65	5.50	V
		FSA1256A, FSA1257A, FSA1258A	2.70	5.50	
V _{IN}	Control Input Voltage ^(Error! Reference source not found.)	0	V _{CC}	V	
V _{IN}	Switch Input Voltage	0	V _{CC}	V	
Θ _{JA}	Thermal Resistance in Still Air, MicroPak 8L Package (Modeled)		224	°C/W	
T _A	Operating Temperature	-40	+85	°C	

Note:

2. Unused inputs must be held HIGH or LOW. They must not float.

DC Electrical Characteristics

All typical values are at 25°C unless otherwise specified. The 1.65V to 1.95V range applies to FSA1256, FSA1257, and FSA1258 only.

Symbol	Parameter	Conditions	V_{CC} (V)	$T_A=+25^\circ\text{C}$			$T_A=-40$ to $+85^\circ\text{C}$		Unit
				Min.	Typ.	Max.	Min.	Max.	
V_{IH}	Input Voltage High ⁽³⁾		4.5 to 5.5				2.4		V
			2.7 to 3.6				2.0		
			1.65 to 1.95				0.9		
V_{IL}	Input Voltage Low ⁽³⁾		4.5 to 5.5					0.8	V
		FSA1256A, FSA1257A, FSA1258A Only	2.7 to 3.6					0.4	
		FSA1256, FSA1257, FSA1258 Only	2.7 to 3.6					0.6	
			1.65 to 1.95					0.4	
I_{IN}	Control Input Leakage (S)	$V_{IN}=0$ to V_{CC}	1.95 to 5.5				-1	1	μA
$I_{NO(OFF)}, I_{NC(OFF)}$	Off Leakage Current	A=1V, 4.5V 1B or 2B=1V, 4.5V	5.5	-2		2	-20	20	nA
R_{ON}	Switch On Resistance ^(3,4)	$I_{OUT}=100\text{mA}$, 1B or 2B=3.5V	4.5		0.95	1.15		1.30	Ω
		$I_{OUT}=100\text{mA}$, 1B or 2B=1.5V	2.7		2.6	4.0		4.3	
		$I_{OUT}=100\text{mA}$, 1B or 2B=1.2V	1.65		8.0	9.5		10.5	
ΔR_{ON}	On Resistance Matching Between Channels ^(3,5)	$I_{OUT}=100\text{mA}$, 1B or 2B=3.5V	4.5		0.06	0.12		0.15	Ω
$R_{FLAT(ON)}$	On Resistance Flatness ^(3,6)	$I_{OUT}=100\text{mA}$, 1B or 2B=0V, 1.0V, 2.0V	4.5		0.2	0.3		0.4	Ω
		$I_{OUT}=100\text{mA}$, 1B or 2B=0V, 0.75V, 1.5V	2.7		1.4				
		$I_{OUT}=100\text{mA}$, 1B or 2B=0V, 1.0V, 1.2V	1.65		1.8				
I_{CC}	Quiescent Supply Current	$V_{IN}=0\text{V}$ or V_{CC} , $I_{OUT}=0\text{V}$	5.5		0.1	0.5		1.0	μA
			3.6		0.1	0.5		1.0	
I_{CCT}	Increase in I_{CC} per Input	One Input at 2.6V, Others at V_{CC} or GND (FSA1256A, FSA1257A, FSA1258A Only)	4.3		0.2			10.0	μA

Notes:

- Guaranteed, but not tested for $V_{CC}=1.65\text{V}$.
- On resistance is determined by the voltage drop between A and B pins at the indicated current through the switch.
- $\Delta R_{ON}=R_{ON\text{ max}} - R_{ON\text{ min}}$ measured at identical V_{CC} , temperature, and voltage.
- Flatness is defined as the difference between the maximum and minimum value of on resistance (R_{ON}) over the specified range of conditions.

AC Electrical Characteristics

All typical values are at 25°C unless otherwise specified. The 1.65V to 1.95V range applies to FSA1256, FSA1257, and FSA1258 only.

Symbol	Parameter	Conditions	V _{CC} (V)	T _A =+25°C			T _A =-40 to +85°C		Unit	Figure
				Min.	Typ.	Max.	Min.	Max.		
t _{ON}	Turn-On Time ⁽⁷⁾	1B or 2B=3.0V, R _L =50Ω, C _L =35pF	4.5 to 5.5		10	35		40	ns	8
		1B or 2B=1.5V, R _L =50Ω, C _L =35pF	2.7 to 3.6		15	50		60		
		1B or 2B=1.0V R _L =50Ω, C _L =35pF	1.65 to 1.95		35	110		120		
t _{OFF}	Turn-Off Time ⁽⁷⁾	1B or 2B=3.0V, R _L =50Ω, C _L =35pF	4.5 to 5.5		4	15		20	ns	8
		1B or 2B=1.5V, R _L =50Ω, C _L =35pF	2.7 to 3.6		8	20		30		
		1B or 2B=1.0V R _L =50Ω, C _L =35pF	1.65 to 1.95		10	30		40		
t _{BMM}	Break-Before-Make Time ⁽⁷⁾	1B or 2B=3.0V, R _L =50Ω, C _L =35pF	4.5 to 5.5		7				ns	9
		1B or 2B=1.5V, R _L =50Ω, C _L =35pF	2.7 to 3.6		12					
Q	Charge Injection ⁽⁷⁾	C _L =1.0nF, V _{GEN} =0V, R _{GEN} =0Ω	4.5 to 5.5		20				pC	13
			2.7 to 3.6		10					
			1.65 to 1.95		5					
OIRR	Off Isolation ⁽⁷⁾	f=1MHz, R _L =50Ω,	1.65 to 5.5		-70				dB	11
Xtalk	Crosstalk ⁽⁷⁾	f=1MHz, R _L =50Ω,	1.65 to 4.3		-100				dB	12
BW	-3db Bandwidth ⁽⁷⁾	R _L =50Ω	1.65 to 4.3		300				MHz	10
THD	Total Harmonic Distortion ⁽⁷⁾	f=20Hz to 20kHz, R _L =600Ω, V _{IN} =0.5V _{PP}	1.65 to 4.3		0.002				%	16

Notes:

7. Guaranteed, but not tested for V_{CC}=1.65V.

Capacitance

Symbol	Parameter	Conditions	V _{CC} (V)	T _A =+25°C			Unit	Figure
				Min.	Typ.	Max.		
C _{IN}	Control Pin Input Capacitance	f=1MHz	0		3.0		pF	15
C _{OFF}	B Port Off Capacitance	f=1MHz	4.5		11.5		pF	14
C _{ON}	A Port On Capacitance	f=1MHz	4.5		27.0		pF	15

Test Diagrams

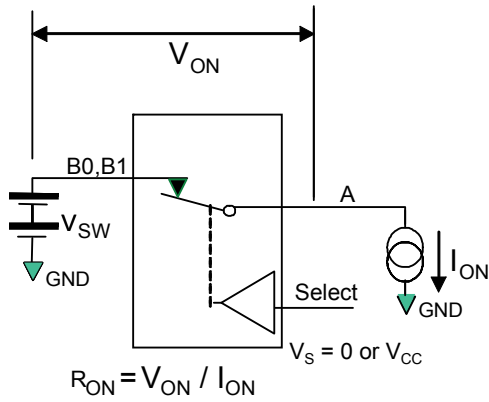

Figure 4. On Resistance

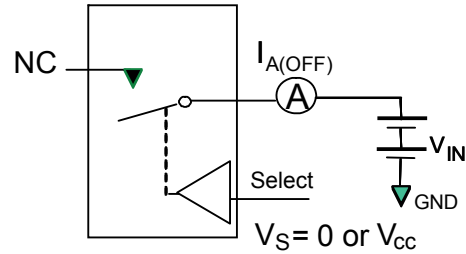

Figure 5. Off Leakage (Ports Tested Separately)

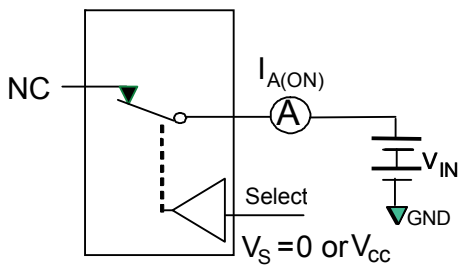

Figure 6. On Leakage

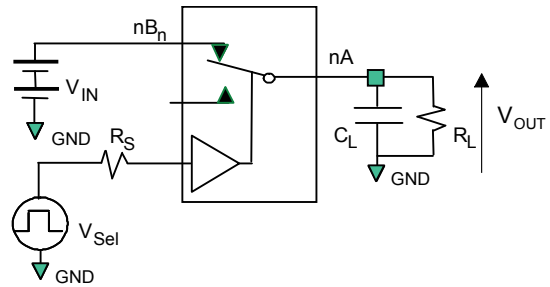

Figure 7. Test Circuit Load

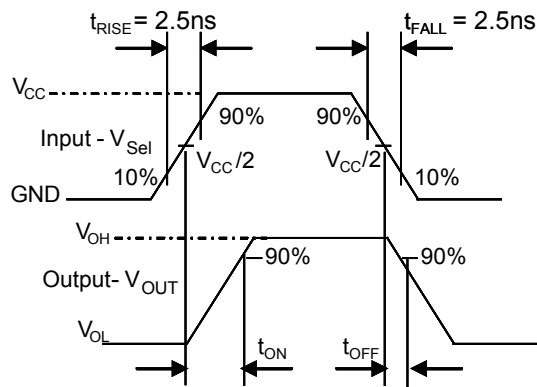

Figure 8. Turn-On / Turn-Off Waveforms

Test Diagrams (Continued)

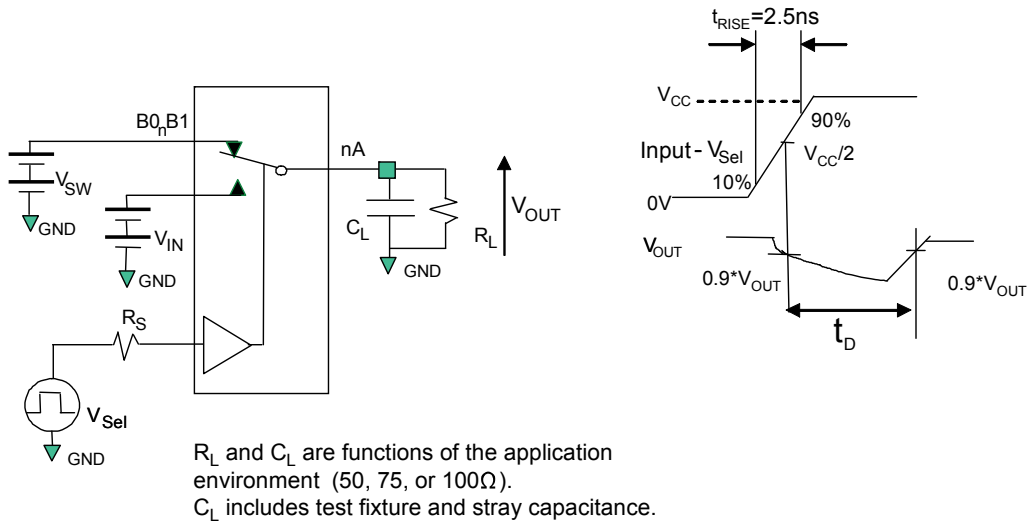

Figure 9. Break-Before-Make Interval Timing

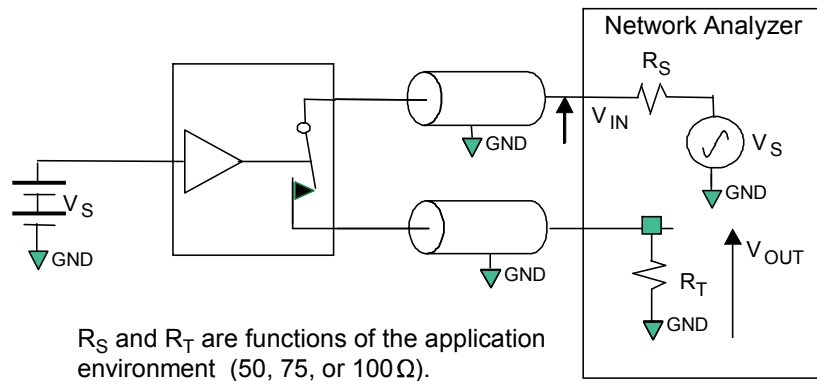

Figure 10. Bandwidth

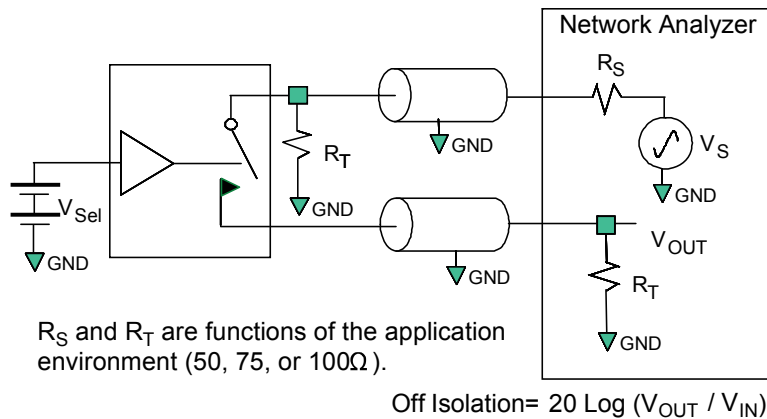

Figure 11. Channel Off Isolation

Test Diagrams (Continued)

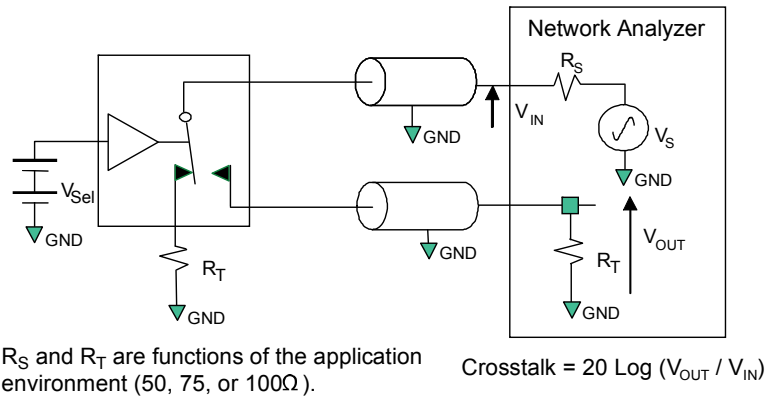

Figure 12. Adjacent Channel Crosstalk

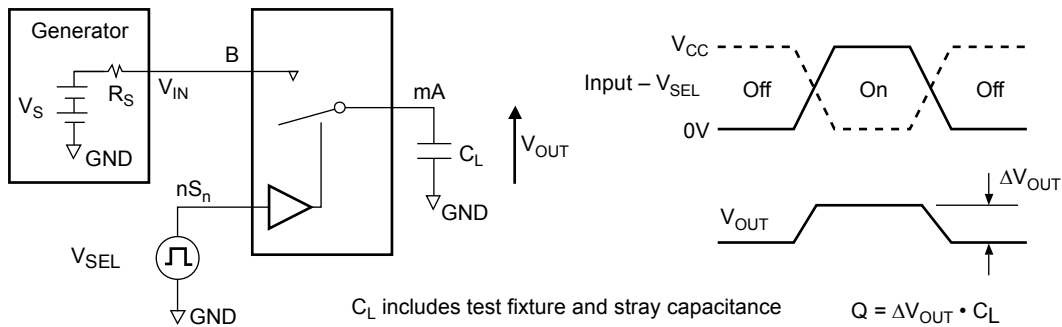

Figure 13. Charge Injection Test

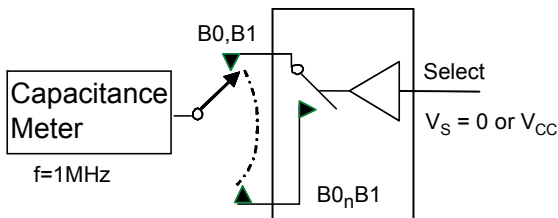

Figure 14. Channel Off Capacitance

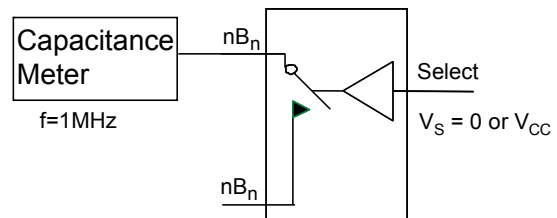

Figure 15. Channel On Capacitance

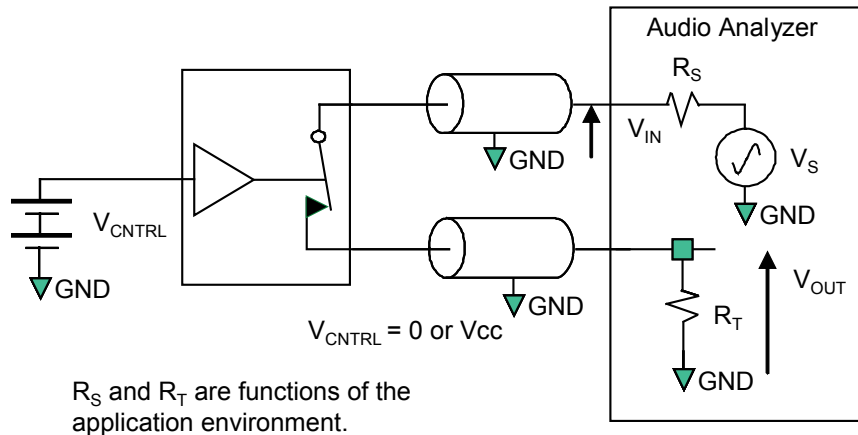
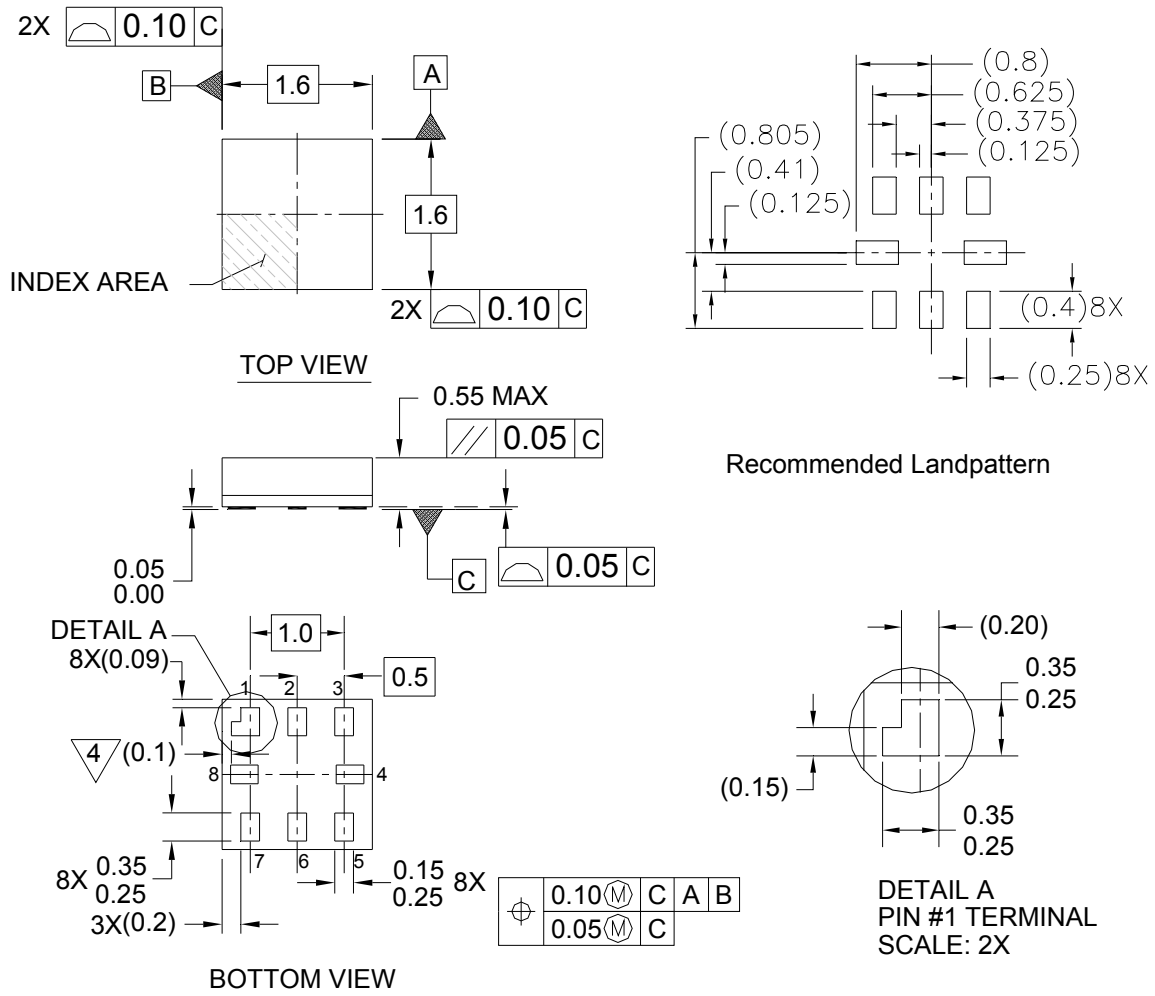

Figure 16. Total Harmonic Distortion

Physical Dimensions



Notes:

1. PACKAGE CONFORMS TO JEDEC MO-255 VARIATION UAAD
2. DIMENSIONS ARE IN MILLIMETERS
3. DRAWING CONFORMS TO ASME Y.14M-1994
4. PIN 1 FLAG, END OF PACKAGE OFFSET
5. DRAWING FILE NAME: MKT-MAC08AREV4

MAC08AREV4

Figure 17. 8-Lead MicroPak™, 1.6mm Wide

For tape and reel specifications for MicroPak, please visit:
http://www.fairchildsemi.com/products/logic/pdf/micropak_tr.pdf



Package drawings are provided as a service to customers considering Fairchild components. Drawings may change in any manner without notice. Please note the revision and/or date on the drawing and contact a Fairchild Semiconductor representative to verify or obtain the most recent revision. Package specifications do not expand the terms of Fairchild's worldwide terms and conditions, specifically the warranty therein, which covers Fairchild products.

Always visit Fairchild Semiconductor's online packaging area for the most recent package drawings:
<http://www.fairchildsemi.com/packaging/>



TRADEMARKS

The following includes registered and unregistered trademarks and service marks, owned by Fairchild Semiconductor and/or its global subsidiaries, and is not intended to be an exhaustive list of all such trademarks.

- | | | | |
|--|--|--|---|
| 2Cool™ | F-PFS™ | PowerTrench® | The Power Franchise® |
| AccuPower™ | FRFET® | PowerXS™ | the power franchise |
| AX-CAP™* | Global Power Resource™ | Programmable Active Droop™ | TinyBoost™ |
| BitSiC™ | GreenBridge™ | QFET® | TinyBuck™ |
| Build it Now™ | Green FPS™ | QS™ | TinyCalc™ |
| CorePLUS™ | Green FPS™ e-Series™ | Quiet Series™ | TinyLogic® |
| CorePOWER™ | Gmax™ | RapidConfigure™ | TINYOPTO™ |
| CROSSVOLT™ | GTO™ |  ™ | TinyPower™ |
| CTL™ | IntelliMAX™ | Saving our world, 1mW/WkW at a time™ | TinyPWM™ |
| Current Transfer Logic™ | ISOPANAR™ | SignalWise™ | TinyWire™ |
| DEUXPEED® | Making Small Speakers Sound Louder and Better™ | SmartMax™ | TranSiC™ |
| Dual Cool™ | MegaBuck™ | SMART START™ | TriFault Detect™ |
| EcoSPARK® | MICROCOUPLER™ | Solutions for Your Success™ | TRUECURRENT®* |
| EfficientMax™ | MicroFET™ | SPM® | µSerDes™ |
| ESBC™ | MicroPak™ | STEALTH™ |  SerDes™ |
|  Fairchild® | MicroPak2™ | SuperFET® | UHC® |
| Fairchild Semiconductor® | MillerDrive™ | SuperSOT™-3 | Ultra FRFET™ |
| FACT Quiet Series™ | MotionMax™ | SuperSOT™-6 | UniFET™ |
| FACT® | Motion-SPM™ | SuperSOT™-8 | VCX™ |
| FAST® | mWSaver™ | SupreMOS® | VisualMax™ |
| FastvCore™ | OptoHIT™ | SyncFET™ | VoltagePlus™ |
| FETBench™ | OPTOLOGIC® | Sync-Lock™ | XS™ |
| FlashWriter®* | OPTOPLANAR® |  SYSTEM GENERAL®* | |
| FPS™ | | | |

* Trademarks of System General Corporation, used under license by Fairchild Semiconductor.

DISCLAIMER

FAIRCHILD SEMICONDUCTOR RESERVES THE RIGHT TO MAKE CHANGES WITHOUT FURTHER NOTICE TO ANY PRODUCTS HEREIN TO IMPROVE RELIABILITY, FUNCTION, OR DESIGN. FAIRCHILD DOES NOT ASSUME ANY LIABILITY ARISING OUT OF THE APPLICATION OR USE OF ANY PRODUCT OR CIRCUIT DESCRIBED HEREIN; NEITHER DOES IT CONVEY ANY LICENSE UNDER ITS PATENT RIGHTS, NOR THE RIGHTS OF OTHERS. THESE SPECIFICATIONS DO NOT EXPAND THE TERMS OF FAIRCHILD'S WORLDWIDE TERMS AND CONDITIONS, SPECIFICALLY THE WARRANTY THEREIN, WHICH COVERS THESE PRODUCTS.

LIFE SUPPORT POLICY

FAIRCHILD'S PRODUCTS ARE NOT AUTHORIZED FOR USE AS CRITICAL COMPONENTS IN LIFE SUPPORT DEVICES OR SYSTEMS WITHOUT THE EXPRESS WRITTEN APPROVAL OF FAIRCHILD SEMICONDUCTOR CORPORATION.

As used herein:

1. Life support devices or systems are devices or systems which, (a) are intended for surgical implant into the body or (b) support or sustain life, and (c) whose failure to perform when properly used in accordance with instructions for use provided in the labeling, can be reasonably expected to result in a significant injury of the user.
2. A critical component in any component of a life support, device, or system whose failure to perform can be reasonably expected to cause the failure of the life support device or system, or to affect its safety or effectiveness.

ANTI-COUNTERFEITING POLICY

Fairchild Semiconductor Corporation's Anti-Counterfeiting Policy. Fairchild's Anti-Counterfeiting Policy is also stated on our external website, www.fairchildsemi.com, under Sales Support.

Counterfeiting of semiconductor parts is a growing problem in the industry. All manufacturers of semiconductor products are experiencing counterfeiting of their parts. Customers who inadvertently purchase counterfeit parts experience many problems such as loss of brand reputation, substandard performance, failed applications, and increased cost of production and manufacturing delays. Fairchild is taking strong measures to protect ourselves and our customers from the proliferation of counterfeit parts. Fairchild strongly encourages customers to purchase Fairchild parts either directly from Fairchild or from Authorized Fairchild Distributors who are listed by country on our web page cited above. Products customers buy either from Fairchild directly or from Authorized Fairchild Distributors are genuine parts, have full traceability, meet Fairchild's quality standards for handling and storage and provide access to Fairchild's full range of up-to-date technical and product information. Fairchild and our Authorized Distributors will stand behind all warranties and will appropriately address any warranty issues that may arise. Fairchild will not provide any warranty coverage or other assistance for parts bought from Unauthorized Sources. Fairchild is committed to combat this global problem and encourage our customers to do their part in stopping this practice by buying direct or from authorized distributors.

PRODUCT STATUS DEFINITIONS

Definition of Terms

Datasheet Identification	Product Status	Definition
Advance Information	Formative / In Design	Datasheet contains the design specifications for product development. Specifications may change in any manner without notice.
Preliminary	First Production	Datasheet contains preliminary data; supplementary data will be published at a later date. Fairchild Semiconductor reserves the right to make changes at any time without notice to improve design.
No Identification Needed	Full Production	Datasheet contains final specifications. Fairchild Semiconductor reserves the right to make changes at any time without notice to improve the design.
Obsolete	Not In Production	Datasheet contains specifications on a product that is discontinued by Fairchild Semiconductor. The datasheet is for reference information only.

Rev. I61