



March 2010



FSA2000

Auto-Selecting HS-USB Switch with Cap-Free Headphone Audio Amplifier

Features

Switch Type	USB + Headphone Amplifier
Switch Mechanism	Auto (USB with V_{BUS})
USB Detection	YES
USB	USB 2.0 High Speed & Full-Speed Compliant
Audio Amplifier	Class AB
Amplifier Output Power	40mW _{RMS} (32Ω)
Amplifier Gain	0dB
THD+N	0.1%
SNR	-90dB
PSRR	-95dB
V_{CC}	2.7 to 4.3V
I_{CC} (Audio)	3mA
I_{CC} (USB)	6μA
Package	16- Lead UMLP 1.80 x 2.60 x 0.55mm, 0.40mm pitch
Ordering Information	FSA2000UMX

Description

The FSA2000 is a low-cost integrated HS-USB and audio switch that incorporates an audio headphone amplifier. This solution eliminates many of the discrete parts currently used in stereo headset applications. It provides stereo headphone drivers designed to operate with a ground-centered output signal. This allows for the removal of large and expensive DC blocking capacitors. The headphone drivers are capable of driving up to 40mW_{RMS} per channel.

Related Resources

- [FSA2000 Demonstration Board](#)
- [FSA2000 Evaluation Board](#)
- [FDB323 — FSA2000 Demonstration Board User Guide](#)
- [FEB322 — FSA2000 Evaluation Board User Guide](#)
- [AN-8032 — Demonstration Board Quick-Start Guide](#)
- [AN-8031 — Utilizing the FSA2000 MUTE Function to Reduce Audio “Click” and “Pop”](#)
- For samples, questions, or board requests; please contact: Analog.Switch@fairchildsemi.com.

Applications

- MP3 Portable Media Players
- Cellular Phones, Smartphones

Typical Application

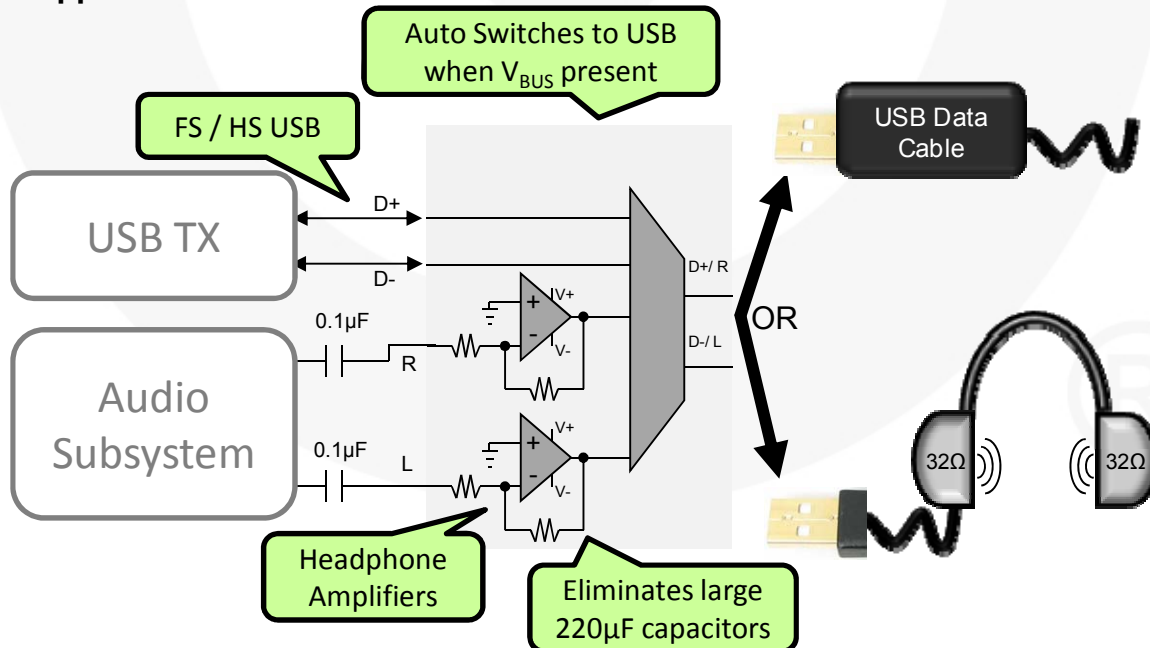

Figure 1. Mobile Phone Example

Pin Descriptions

Pin #	Name	Type	Description
1	D+	I/O	USB D+ port from processor or transceiver
2	D-	I/O	USB D- port from processor or transceiver
3	R	Input	Right audio channel input
4	L	Input	Left audio channel input
5	V _{CC}	Audio Supply	Supply voltage for audio amplifiers, charge pump, and audio control; not required for USB path
6	MUTE	Input	Control pin intended to be used temporarily to quiet transients on the audio path upon transition of /SHDN. Ground if not being used.
7	/SHDN	Input	Shutdown Enable (Requires V _{CC} only)
8	GND	GND	IC ground
9	D-/L	I/O	Common USB/Audio Port; USB D- data to connector or left audio channel output
10	D+/R	I/O	Common USB/Audio Port; USB D+ data to connector or right audio channel output
11	V _{BUS}	Input/Supply	USB input select pin and USB supply
12	V+	Node	Node for filtering internal positive amplifier rail; suggest 1μF to GND
13	V-	Input	Negative amplifier rail input; suggest 1μF to GND. Requires connection to CPO.
14	CPO	Output	Charge pump output used to drive V-, suggest 2.2 μF to GND for filtering.
15	CM	I/O	Charge pump negative flying capacitor pin; connect to CP via storage capacitor, typically 1μF.
16	CP	I/O	Charge pump positive flying capacitor pin; connect to CM via storage capacitor, typically 1μF.

Pin Configuration

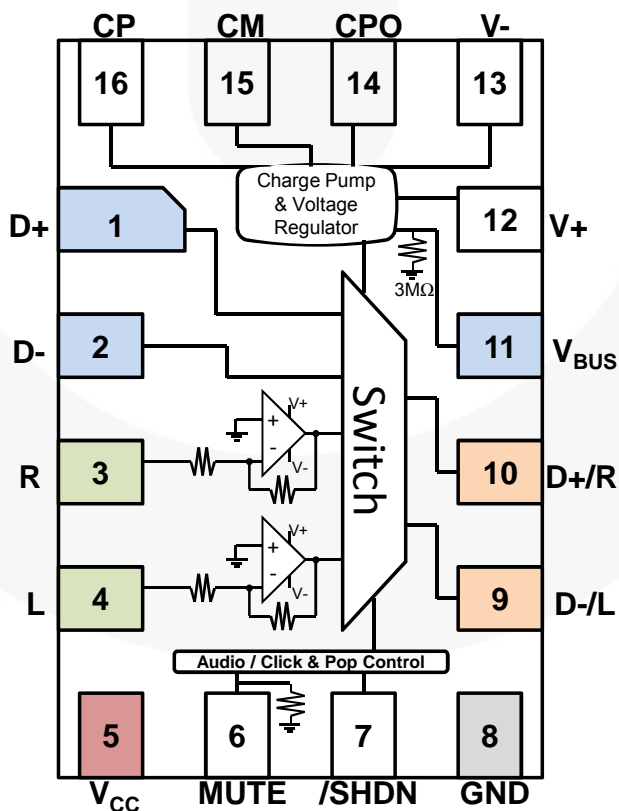

Figure 2. FSA2000UMX (Top View)

Functional Diagram

Functional Mode	Power Down	Audio Power Down	Transient Suppression	Audio Mode	USB Mode
V_{BUS}	LOW	LOW	LOW	LOW	HIGH
V_{CC}	LOW	HIGH	HIGH	HIGH	X ⁽¹⁾
/SHDN	X ⁽¹⁾	LOW	HIGH	HIGH	X ⁽¹⁾
MUTE	X ⁽¹⁾	X ⁽¹⁾	HIGH	LOW	X ⁽¹⁾
Charge Pump	OFF	OFF	ON	ON	OFF
R/L Amplifiers	OFF	OFF	OFF	ON	OFF
D+/R, D-/L	HI-Z	HI-Z	D+/R, D-/L=0V	R/L	D+/D-
Figure 3 Label	A	B	C	D	E

Notes:

- The (X) indicates "Don't Care" state.

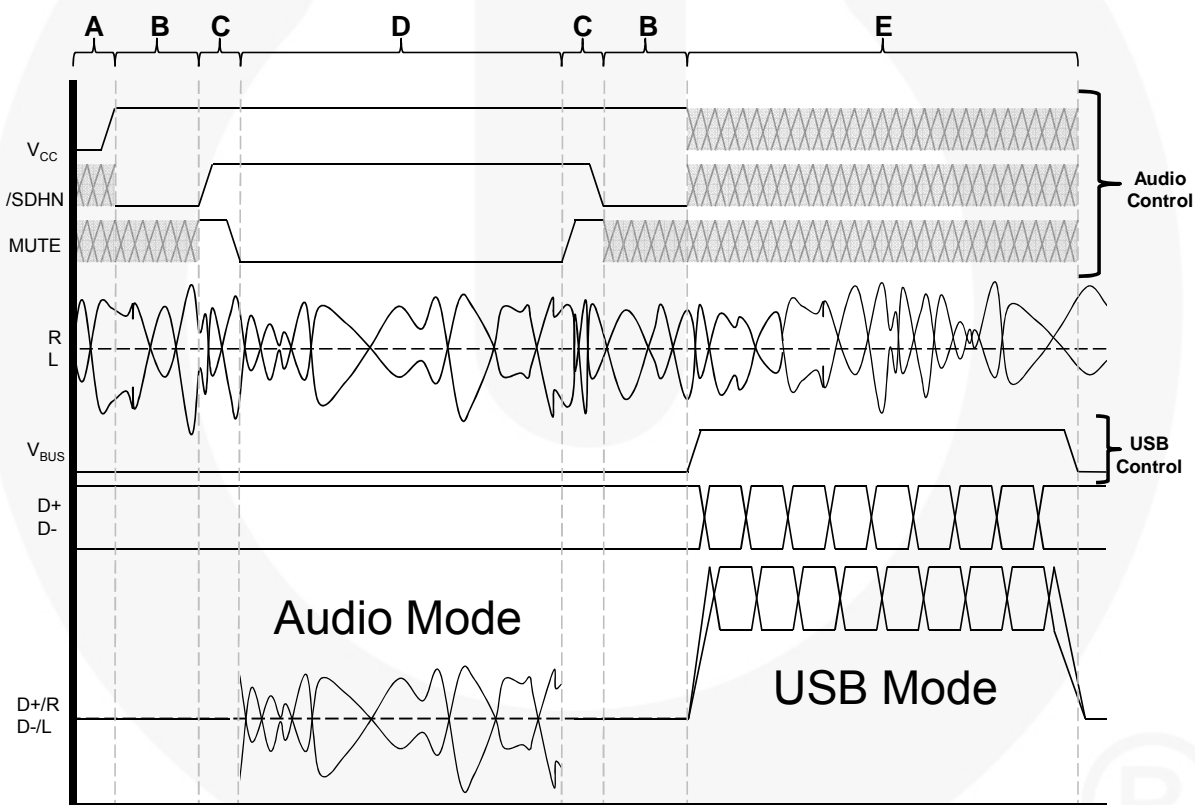

Figure 3. Functional Diagram

- Audio Power Down** – An active-LOW shutdown pin (/SHDN) allows the amplifiers to be placed in low-power (or shutdown) mode to conserve battery power. While the FSA2000 is in shutdown mode, USB data transfers are allowed whenever a USB cable is connected to a host (V_{BUS} is HIGH). The audio amplifiers are enabled and connected to the common port when /SHDN is HIGH and V_{BUS} is LOW.
- Transient Suppression** – The FSA2000 audio amplifier has a soft turn-on feature that suppresses click and pop on the audio path when the path is selected. In addition to the soft turn-on feature of the amplifier, the MUTE pin mutes the audio path when asserted HIGH. The mute functionality also has an internal pull-down that disables mute if the MUTE pin is floated. The MUTE pin allows control of the mute functionality by the application. Please refer to application note AN-8031, describing the recommended timing and control of MUTE for optimal performance.

Functional Description

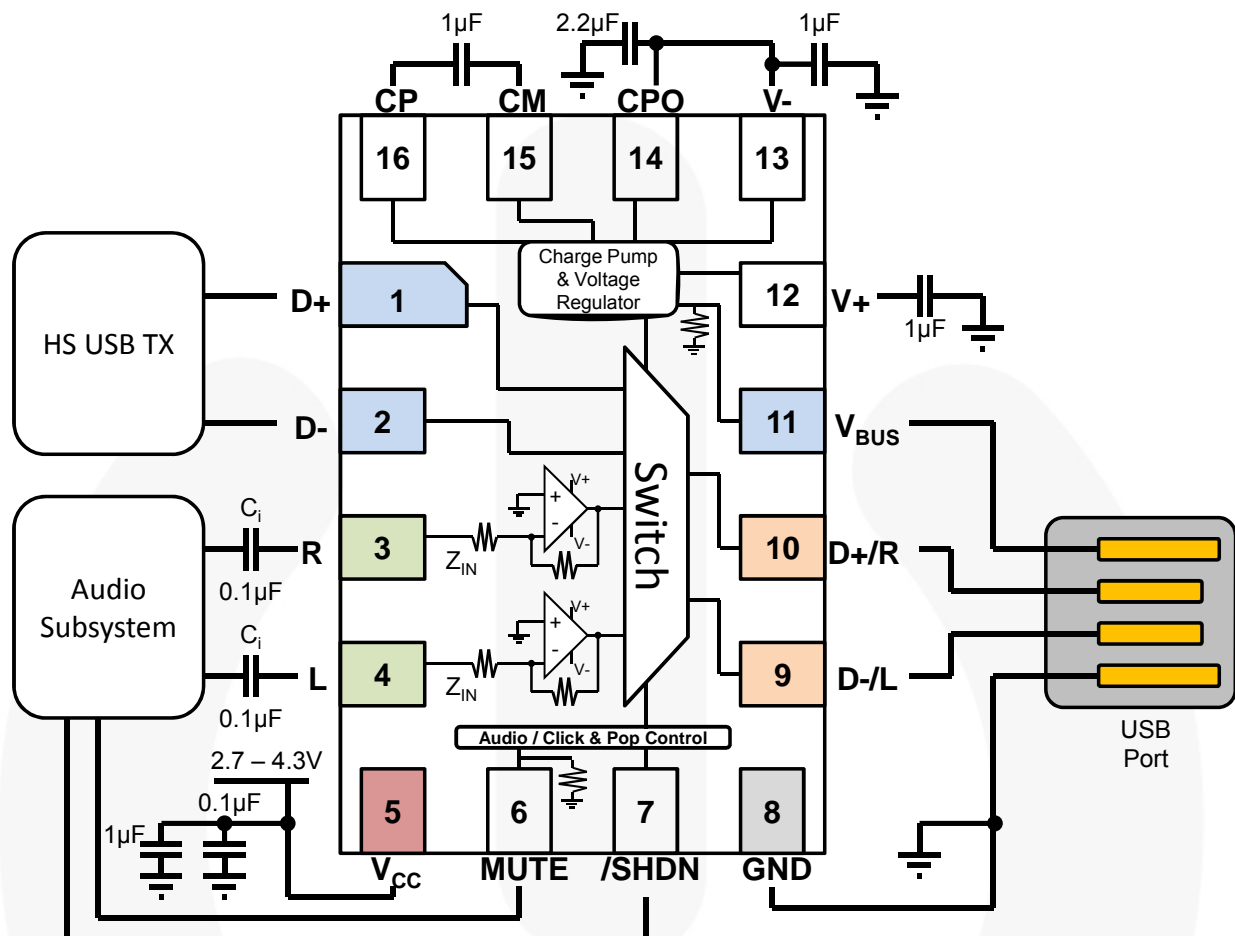

Figure 4. Micro-USB Application

Application Guidelines

- **Device Placement** – Minimize to USB port & USB TX.
- **PIN 1, 2, 9, 10** – Minimize and match trace lengths for USB compliance.
- **PIN 3, 4** – Suggest 0.1µF capacitor as close to the device as possible for DC-blocking and setting low-frequency response of audio amplifier. The input capacitors combine with the input impedance of the amplifiers to form a high-pass filter. Equation 1 can be used to calculate the -3dB cut-off frequency of the high-pass filter for the given input capacitor value and the FSA2000 input impedance.

$$f_{-3dB} = \frac{1}{2\pi \cdot Z_{IN} C_i} \quad (1)$$

$$17.7Hz = \frac{1}{2\pi(90k\Omega)(0.1\mu F)} \quad (2)$$

- It is desirable to be below the 20Hz audio range. Users have flexibility to adjust capacitor for audio

performance in the system design. Equation 2 shows the cut-off frequency of the recommended guidelines.

- **PIN 5** – Use standard decoupling devices, 0.1µF & 1µF capacitors; as close to the device as possible.
- **PIN 8** – Minimize ground trace length between headphone connector and device; minimize ground path resistance.
- **PIN 12** – Suggested 0.1µF capacitor to GND for filtering; as close to the device as possible.
- **PIN 13, 14** – Use low-ESR (equivalent series resistance) ceramic capacitors for lowest charge pump impedance, which provides maximum output power of the audio amplifiers. Recommended to place the components as close as possible to the device.
- **PIN 15, 16** - The charge pump has been optimized for low-ESR ceramic capacitors for the flying capacitor between CP and CM, along with the output capacitors on V+, CPO, and V-. Optimized values for these capacitors are in Figure 4.

Detailed Description

USB Compliance

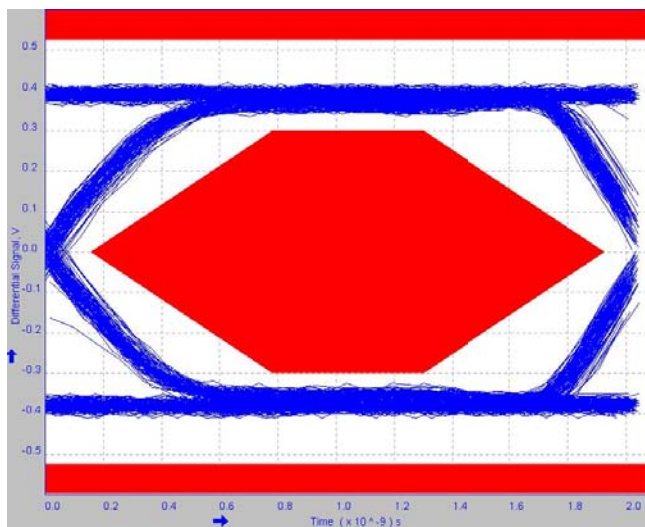

Figure 5. High-Speed USB 2.0 Eye Compliance (5.5V)

Transient Suppression

A common issue with headphone amplifiers is audible noises through the headset when the amplifier is powering up or down. Sharp transients often occur on the audio outputs during this transition that cause audible “click and pop.” The FSA2000 prevents these transients during power-up by muting the outputs until the internal charge pumps are stable. This ensures that any transients caused by the charge pump are not propagated to the outputs. In cases where the application needs a longer startup time for mute, the FSA2000 has a MUTE pin that allows application control

over the behavior of the amplifier during startup and power down. The MUTE pin forces the audio outputs into a known and controlled state so that any transients of the amplifier are not propagated to the headphones as clicks and pops. Figure 6 shows the correct timing of the MUTE pin in relation to the /SHDN pin for optimal click and pop performance.

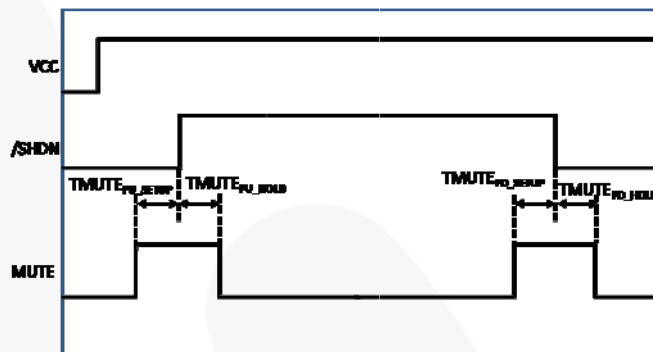

Figure 6. Power-Up and Power-Down Timing

Table 1. Recommended MUTE Timing

Parameter	Description	Suggested Timing
TMUTE _{PU_SETUP}	MUTE setup time to /SHDN rising edge	≥500ns
TMUTE _{PU_HOLD}	MUTE hold time to /SHDN rising edge	~500ns
TMUTE _{PD_SETUP}	MUTE setup time to /SHDN falling edge	≥500ns
TMUTE _{PD_HOLD}	MUTE hold time to /SHDN falling edge	~500ns

Absolute Maximum Ratings

Stresses exceeding the absolute maximum ratings may damage the device. The device may not function or be operable above the recommended operating conditions and stressing the parts to these levels is not recommended. In addition, extended exposure to stresses above the recommended operating conditions may affect device reliability. The absolute maximum ratings are stress ratings only.

Symbol	Parameter		Min.	Max.	Unit
V _{CC}	Supply Voltage	Audio Mode	-0.3	+4.5	V
		USB Mode	-0.3	+6.0	
V _{BUS}	Supply Voltage		-0.3	+6.0	V
V _{CNTRL}	Control Pin Voltage - /SHDN, MUTE		-0.3	+6.0	V
V _{SWUSB}	USB I/O		V _{BUS} - 6.0	V _{BUS} + 0.3	V
V _{SWAUDIO}	Audio I/O		V _{CC} - 6.0	V _{CC} + 0.3	V
I _{SW}	Switch I/O Current (Continuous)			30	mA
I _{PEAK}	Peak Switch I/O Current (Pulsed, 1ms Duration, <10% Duty Cycle)			50	mA
T _J	Junction Temperature			+150	°C
T _{STG}	Storage Temperature Range		-65	+150	°C
T _L	Lead Temperature (Soldering, 10 seconds)			+240	°C
ESD	IEC 61000-4-2 System	USB Connector pins (D+/R, D-/L, V _{BUS})	Air Gap	15	kV
	JEDEC JESD22-A114, Human Body Model		D+/R, D-/L	4	
			All Other Pins	2	
			V _{BUS}	1	
JEDEC JESD22-C101, Charged Device Model		All Pins	2		

Recommended Operating Conditions

The Recommended Operating Conditions table defines the conditions for actual device operation. Recommended operating conditions are specified to ensure optimal performance to the datasheet specifications. Fairchild does not recommend exceeding these ratings or designing to Absolute Maximum Ratings.

Symbol	Parameter	Min.	Typ.	Max.	Unit
V _{BUS}	USB Supply Voltage	4.0	5.0	5.5	V
V _{CC}	Supply Voltage	2.7	3.3	4.5	V
V _{CNTRL}	Control Voltage - /SHDN, MUTE	0		V _{CC}	V
V _{SWUSB}	D+/L, D-/R, D+, D- Input Range	0		V _{BUS}	V
V _{SWAUDIO}	L,R Audio Input Range	-2.5		V _{CC}	V
V _{SWING}	L,R Audio Input Amplitude			5	V _{P-P}
T _A	Temperature Range	-40	+25	+85	°C
Z _{LOAD}	Headset Load Impedance	16	32		Ω
θ _{JA}	Package Thermal Resistance, JEDEC Standard Multi-Layer Boards, Still Air		40		°C/W

DC Electrical Characteristics

$T_A = 25^\circ\text{C}$, $V_{CC} = 3.0\text{V}$, audio inputs at -6dBV and AC coupled with $0.1\mu\text{F}$, audio outputs DC coupled into 32Ω loads referenced to 1kHz , unless otherwise noted.

Symbol	Parameter	V_{CC} (V)	Conditions	$T_A = -40^\circ\text{C to }+85^\circ\text{C}$			Unit
				Min.	Typ.	Max.	
Common Pins							
V_{IH}	/SHDN, MUTE, Control Input Voltage HIGH	2.7 to 4.5		1.65			V
V_{IL}	Control Input Voltage LOW	2.7 to 4.5				0.5	
I_{IN}	/SHDN, MUTE, Input HIGH Current	4.5	$V_{CNTRL} = 3.6\text{V}$	-1		10	μA
			$V_{CNTRL} = 0\text{V}$	-1		1	
I_{OFF}	Power Off Leakage Current	$V_{CC} = V_{BUS} = 0$	Common Port (D+/R, D-/L) $V_{SW} = 0\text{V}, 5.5\text{V}$			10	μA
$I_{NO(OFF)}$	Off-Leakage Current of Port D+, D-	3.6	D+/R, D-/L = 0.3V , $V_{CC} - 0.3\text{V}$, D+, D- = 0.3V , $V_{CC} - 0.3\text{V}$ or Floating, /SHDN=0V, $V_{BUS}=0\text{V}$, MUTE=0V, R/L=0V	-50	1	50	nA
$I_{NC(ON)}$	On-Leakage Current of Port D+/R or D-/L	3.6	D+/R, D-/L = 0.3V , $V_{CC} - 0.3\text{V}$ D+, D- = Floating $V_{BUS}=5.5\text{V}$, /SHDN=0V, MUTE=0V, R/L=0V	-50	1	50	nA
R_{PD}	V_{BUS} , MUTE, Internal Pull-Down Resistor				3.5		$\text{M}\Omega$
USB Switch Path							
	USB Analog Signal Range			0		3.6	V
R_{ONUSB}	HS Switch On Resistance ⁽²⁾	$V_{BUS}=5$	$V_{D+/D-} = 0\text{V}, 0.4\text{V}$, $I_{ON} = -8\text{mA}$		4.0	6.5	Ω
ΔR_{ONUSB}	HS Delta R_{ON} ^(2,3)	$V_{BUS}=5$	$V_{D+/D-} = 0\text{V}$, $I_{ON} = -8\text{mA}$		0.4		Ω
Audio Amplifier Path							
Z_{IN}	Audio Amp Input Impedance ⁽⁴⁾	3.0 to 4.5			90		$\text{k}\Omega$
Power Supply							
$I_{CC(Audio)}$	Quiescent Supply Current (Audio Mode)	4.5	$I_{OUT} = 0$, /SHDN = V_{CC} , MUTE=0V, D+/D-=0V		3	5	mA
$I_{CC(SHDN)}$	Quiescent Supply Current (V_{CC}) in Shutdown Mode	4.5	$I_{OUT} = 0$, /SHDN = 0V, MUTE=0V, D+/D-=0V		1	5	μA
$I_{CC(USB)}$	Quiescent Supply Current (USB Mode)	$V_{BUS}=5.5$	$I_{OUT}=0$, MUTE=0V, /SHDN= V_{BUS} , L/R=0V		6	10	μA

Notes:

- On resistance is determined by the voltage drop between the D+/D- and D+/R,D-/L pins at the indicated current through the switch.
- $\Delta R_{ON} = R_{ON_max} - R_{ON_min}$ measured at identical V_{CC} , temperature, and voltage.
- Guaranteed by characterization, but not production tested.

AC Electrical Characteristics

$T_A = 25^\circ\text{C}$, $V_{CC} = 3.0\text{V}$, audio inputs at -6dBV and AC coupled with $0.1\mu\text{F}$, audio outputs DC coupled into 32Ω loads referenced to 1kHz , unless otherwise noted.

Symbol	Parameter	V_{CC} (V)	Conditions	$T_A = -40^\circ\text{C}$ to $+85^\circ\text{C}$			Unit
				Min.	Typ.	Max.	
Audio Amplifier Path							
$t_{ONAUDIO}$	Turn-On Time /SHDN to Output	3.0 to 4.5	$V_{D+R, D-JL} = 1.0\text{V}$; $C_L = 0\text{pF}$,			1	ms
$t_{OFFAUDIO}$	Turn-Off Time /SHDN to Output	3.0 to 4.5	$V_{D+R, D-JL} = 1.0\text{V}$; $C_L = 0\text{pF}$			100	μs
t_{MUTE_ON}	MUTE Turn-On Time	3.0 to 4.5			1		μs
t_{MUTE_OFF}	MUTE Turn-Off Time	3.0 to 4.5			1		μs
P_{out}	Output Power ⁽⁵⁾	2.7	THD _N =1%, $V_{L,R}$ In Phase, $R_{LOAD}=32\Omega$, 1kHz		25		mW_{rms}
		3.3			35		
		4.5			40		
V_{OS}	Output Offset Voltage		Inputs Grounded		5		mV
A_V	Amplifier Gain		Input = -26dBV at 1kHz , $R_L=16\Omega$		0		dB
A_{MATCH}	Gain Matching of L & R Channels ⁽⁵⁾		Input = -26dBV , 20Hz to 20kHz			0.5	dB
f_R	Frequency Response ⁽⁵⁾		20Hz to 20kHz referenced to 1kHz	-1.5		1.5	dB
THD+N	Distortion ⁽⁵⁾		$f=1\text{kHz}$, $V_{sw}=50\text{mV}_{rms}$, $R_L=64\Omega$		0.1		%
SNR	Signal to Noise Ratio ⁽⁵⁾		A Weighted		-90		dB
$XTLK_{SPK}$	Crosstalk between L & R Channel ⁽⁵⁾		Input= -26dBV		-60		dB
USB Switch Path							
t_{PDUSB}	USB Switch Propagation Delay ⁽⁵⁾	4.0 to 5.5	$R_L = 50\Omega$; $C_L = 0\text{pF}$		0.25		ns
t_{ONUSB}	Turn-On Time V_{BUS} to Output	4.0 to 5.5	$V_{D+R, D-JL} = 1.0\text{V}$; $R_L = 32\Omega$; $C_L = 0\text{pF}$, /SHDN, $V_{CC}=0$			5.5	μs
t_{OFFUSB}	Turn-Off Time V_{BUS} to Output	4.0 to 5.5	$V_{D+R, D-JL} = 1.0\text{V}$; $R_L = 32\Omega$; $C_L = 0\text{pF}$, /SHDN, $V_{CC}=0$			2	μs
BW	-3db Bandwidth – USB	4.0 to 5.5	$R_L=50\Omega$, $C_L=0\text{pF}$, Signal 0dBm		720		MHz
Power Supply							
t_{SUPPLY}	Power-Up Stabilization Time		$V+$, $V-$ within 90% of Final Value			1	ms
$PSRR_{SPKR}$	Power Supply Noise Rejection at Common Output ⁽⁵⁾		217Hz 12% Duty Cycle Square Wave 2.7V to 3.2V at V_{CC} Output (D+/R) in V_{rms} as Single Wideband Noise Measurement within $20\text{Hz} - 20\text{kHz}$, A Weighted		-95		dB

Note:

5. Guaranteed by characterization; not production tested.

USB High-Speed-Related AC Electrical Characteristics

$T_A = 25^\circ\text{C}$ unless otherwise noted.

Symbol	Parameter	V_{BUS} (V)	Conditions	$T_A = -40^\circ\text{C}$ to $+85^\circ\text{C}$			Unit
				Min.	Typ.	Max.	
$t_{SK(P)}$	Skew of Opposite Transitions of the Same Output ⁽⁶⁾	4.0 to 5.5	$t_R = t_F = 750\text{ps}$ (10-90%) at 240MHz $C_L = 0\text{pF}$, $R_L = 50\Omega$		35		ps
t_J	Total Jitter ⁽⁶⁾	4.0 to 5.5	$R_L = 50\Omega$, $C_L = 50\text{pF}$, $t_R = t_F = 500\text{ps}$ (10-90%) at 480Mbps (PRBS = $2^{15} - 1$)		130		ps

Note:

6. Guaranteed by characterization; not production tested.

Capacitance

$T_A = 25^\circ\text{C}$ unless otherwise noted.

Symbol	Parameter	V_{CC} / V_{BUS} (V)	Conditions	$T_A = -40^\circ\text{C}$ to $+85^\circ\text{C}$			Unit
				Min.	Typ.	Max.	
C_{IN}	Control Pin Input Capacitance (/SHDN, MUTE)	$V_{CC} = 3.0, 4.5$	$V_{Bias} = 0.05\text{V}$		2.8		pF
C_{ON_USB}	D+, D- (Source Port) On Capacitance	$V_{BUS} = 5.0$	$V_{Bias} = 0.2\text{V}$, $f = 1\text{MHz}$, $f = 240\text{MHz}$		8.8		pF
C_{OFF_USB}	D+, D- (Source Port) Off Capacitance	$V_{BUS} = 5.0$	$f = 1\text{MHz}$		2.8		pF

Physical Dimensions

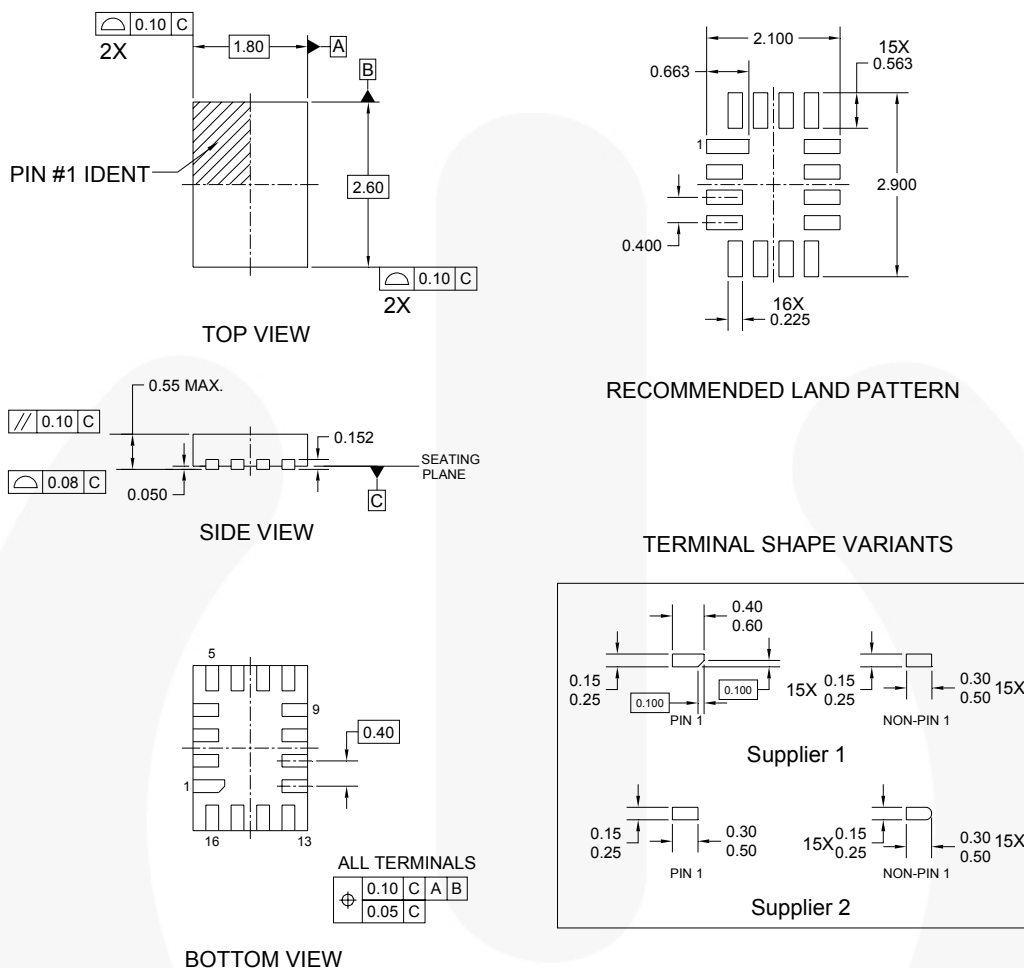

NOTES:

- A. THIS PACKAGE IS NOT CURRENTLY REGISTERED WITH ANY STANDARDS COMMITTEE
- B. DIMENSIONS ARE IN MILLIMETERS.
- C. DIMENSIONS AND TOLERANCES PER ASME Y14.5M, 1994
- D. TERMINAL SHAPE MAY VARY ACCORDING TO PACKAGE SUPPLIER, SEE TERMINAL SHAPE VARIANTS
- E. LAND PATTERN IS A MINIMAL TOE DESIGN
- F. DRAWING FILE NAME : UMLP16AREV3

Figure 7. 16-Pin Ultrathin Molded Leadless Package (UMLP)

Order Number	Operating Temperature Range	Package Description	Packing Method
FSA2000UMX	-40 to 85°C	16-Terminal Ultrathin Molded Leadless Package (UMLP)	Tape & Reel

Package drawings are provided as a service to customers considering Fairchild components. Drawings may change in any manner without notice. Please note the revision and/or date on the drawing and contact a Fairchild Semiconductor representative to verify or obtain the most recent revision. Package specifications do not expand the terms of Fairchild's worldwide terms and conditions, specifically the warranty therein, which covers Fairchild products.

Always visit Fairchild Semiconductor's online packaging area for the most recent package drawings: <http://www.fairchildsemi.com/packaging/>.



TRADEMARKS

The following includes registered and unregistered trademarks and service marks, owned by Fairchild Semiconductor and/or its global subsidiaries, and is not intended to be an exhaustive list of all such trademarks.

AccuPower™
 Auto-SPM™
 Build it Now™
 CorePLUS™
 CorePOWER™
 CROSSVOLT™
 CTL™
 Current Transfer Logic™
 DEUXPEED®
 Dual Cool™
 EcoSPARK®
 EfficientMax™
 ESBC™

 Fairchild®
 Fairchild Semiconductor®
 FACT Quiet Series™
 FACT®
 FAST®
 FastvCore™
 FETBench™
 FlashWriter®
 FPS™

F-PFS™
 FRFET®
 Global Power Resource™
 Green FPS™
 Green FPS™ e-Series™
 Gmax™
 GTO™
 IntelliMAX™
 ISOPLANAR™
 MegaBuck™
 MICROCOUPLER™
 MicroFET™
 MicroPak™
 MicroPak2™
 MillerDrive™
 MotionMax™
 Motion-SPM™
 OptoHit™
 OPTOLOGIC®
 OPTOPLANAR®

 PDP SPM™

Power-SPM™
 PowerTrench®
 PowerXS™
 Programmable Active Droop™
 QFET®
 QS™
 Quiet Series™
 RapidConfigure™

 Saving our world, 1mW/W/kW at a time™
 SignalWise™
 SmartMax™
 SMART START™
 SPM®
 STEALTH™
 SuperFET™
 SuperSOT™-3
 SuperSOT™-6
 SuperSOT™-8
 SupreMOS™
 SyncFET™
 Sync-Lock™

 SYSTEM GENERAL®
 The Power Franchise®

 the power franchise
 TinyBoost™
 TinyBuck™
 TinyCalc™
 TinyLogic®
 TINYOPTO™
 TinyPower™
 TinyPWM™
 TinyWire™
 TriFault Detect™
 TRUCURRENT™
 μSerDes™

 SerDes®
 UHC®
 Ultra FRFET™
 UniFET™
 VCX™
 VisualMax™
 XST™

* Trademarks of System General Corporation, used under license by Fairchild Semiconductor.

DISCLAIMER

FAIRCHILD SEMICONDUCTOR RESERVES THE RIGHT TO MAKE CHANGES WITHOUT FURTHER NOTICE TO ANY PRODUCTS HEREIN TO IMPROVE RELIABILITY, FUNCTION, OR DESIGN. FAIRCHILD DOES NOT ASSUME ANY LIABILITY ARISING OUT OF THE APPLICATION OR USE OF ANY PRODUCT OR CIRCUIT DESCRIBED HEREIN; NEITHER DOES IT CONVEY ANY LICENSE UNDER ITS PATENT RIGHTS, NOR THE RIGHTS OF OTHERS. THESE SPECIFICATIONS DO NOT EXPAND THE TERMS OF FAIRCHILD'S WORLDWIDE TERMS AND CONDITIONS, SPECIFICALLY THE WARRANTY THEREIN, WHICH COVERS THESE PRODUCTS.

LIFE SUPPORT POLICY

FAIRCHILD'S PRODUCTS ARE NOT AUTHORIZED FOR USE AS CRITICAL COMPONENTS IN LIFE SUPPORT DEVICES OR SYSTEMS WITHOUT THE EXPRESS WRITTEN APPROVAL OF FAIRCHILD SEMICONDUCTOR CORPORATION.

As used herein:

1. Life support devices or systems are devices or systems which, (a) are intended for surgical implant into the body or (b) support or sustain life, and (c) whose failure to perform when properly used in accordance with instructions for use provided in the labeling, can be reasonably expected to result in a significant injury of the user.
2. A critical component in any component of a life support, device, or system whose failure to perform can be reasonably expected to cause the failure of the life support device or system, or to affect its safety or effectiveness.

ANTI-COUNTERFEITING POLICY

Fairchild Semiconductor Corporation's Anti-Counterfeiting Policy. Fairchild's Anti-Counterfeiting Policy is also stated on our external website, www.fairchildsemi.com, under Sales Support.

Counterfeiting of semiconductor parts is a growing problem in the industry. All manufacturers of semiconductor products are experiencing counterfeiting of their parts. Customers who inadvertently purchase counterfeit parts experience many problems such as loss of brand reputation, substandard performance, failed applications, and increased cost of production and manufacturing delays. Fairchild is taking strong measures to protect ourselves and our customers from the proliferation of counterfeit parts. Fairchild strongly encourages customers to purchase Fairchild parts either directly from Fairchild or from Authorized Fairchild Distributors who are listed by country on our web page cited above. Products customers buy either from Fairchild directly or from Authorized Fairchild Distributors are genuine parts, have full traceability, meet Fairchild's quality standards for handling and storage and provide access to Fairchild's full range of up-to-date technical and product information. Fairchild and our Authorized Distributors will stand behind all warranties and will appropriately address any warranty issues that may arise. Fairchild will not provide any warranty coverage or other assistance for parts bought from Unauthorized Sources. Fairchild is committed to combat this global problem and encourage our customers to do their part in stopping this practice by buying direct or from authorized distributors.

PRODUCT STATUS DEFINITIONS

Definition of Terms

Datasheet Identification	Product Status	Definition
Advance Information	Formative / In Design	Datasheet contains the design specifications for product development. Specifications may change in any manner without notice.
Preliminary	First Production	Datasheet contains preliminary data; supplementary data will be published at a later date. Fairchild Semiconductor reserves the right to make changes at any time without notice to improve design.
No Identification Needed	Full Production	Datasheet contains final specifications. Fairchild Semiconductor reserves the right to make changes at any time without notice to improve the design.
Obsolete	Not In Production	Datasheet contains specifications on a product that is discontinued by Fairchild Semiconductor. The datasheet is for reference information only.

Rev. 148