

FSB50250UTD

Smart Power Module (SPM®)

Features

- 500V $R_{DS(on)}=4.2\Omega(\text{max})$ 3-phase FRFET inverter including high voltage integrated circuit (HVIC)
- 3 divided negative dc-link terminals for inverter current sensing applications
- HVIC for gate driving and undervoltage protection
- 3/5V CMOS/TTL compatible, active-high interface
- Optimized for low electromagnetic interference
- Isolation voltage rating of 1500Vrms for 1min.
- Embedded bootstrap diode in the package

General Description

FSB50250UTD is a tiny smart power module (SPM®) based on FRFET technology as a compact inverter solution for small power motor drive applications such as fan motors and water suppliers. It is composed of 6 fast-recovery MOSFET (FRFET), and 3 half-bridge HVICs for FRFET gate driving. FSB50250UTD provides low electromagnetic interference (EMI) characteristics with optimized switching speed. Moreover, since it employs FRFET as a power switch, it has much better ruggedness and larger safe operation area (SOA) than that of an IGBT-based power module or one-chip solution. The package is optimized for the thermal performance and compactness for the use in the built-in motor application and any other application where the assembly space is concerned. FSB50250UTD is the most solution for the compact inverter providing the energy efficiency, compactness, and low electromagnetic interference.

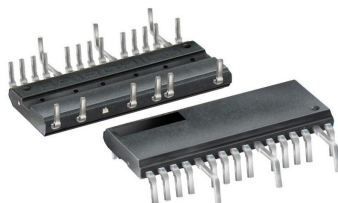

Absolute Maximum Ratings

Symbol	Parameter	Conditions	Rating	Units
V_{PN}	DC Link Input Voltage, Drain-source Voltage of each FRFET		500	V
I_{D25}	Each FRFET Drain Current, Continuous	$T_C = 25^\circ\text{C}$	1.1	A
I_{D80}	Each FRFET Drain Current, Continuous	$T_C = 80^\circ\text{C}$	0.8	A
I_{DP}	Each FRFET Drain Current, Peak	$T_C = 25^\circ\text{C}$, $PW < 100\mu\text{s}$	2.8	A
P_D	Maximum Power Dissipation	$T_C = 25^\circ\text{C}$, Each FRFET	13	W
V_{CC}	Control Supply Voltage	Applied between V_{CC} and COM	20	V
V_{BS}	High-side Bias Voltage	Applied between $V_{B(U)}-U$, $V_{B(V)}-V$, $V_{B(W)}-W$	20	V
V_{IN}	Input Signal Voltage	Applied between IN and COM	-0.3 ~ $V_{CC}+0.3$	V
T_J	Operating Junction Temperature		-40 ~ 150	$^\circ\text{C}$
T_{STG}	Storage Temperature		-40 ~ 125	$^\circ\text{C}$
$R_{\theta JC}$	Junction to Case Thermal Resistance	Each FRFET under inverter operating condition (Note 1)	9.3	$^\circ\text{C}/\text{W}$
V_{ISO}	Isolation Voltage	60Hz, Sinusoidal, 1 minute, Connection pins to heatsink	1500	V_{rms}

Pin Descriptions

Pin Number	Pin Name	Pin Description
1	COM	IC Common Supply Ground
2	$V_{B(U)}$	Bias Voltage for U Phase High Side FRFET Driving
3	$V_{CC(U)}$	Bias Voltage for U Phase IC and Low Side FRFET Driving
4	$IN_{(UH)}$	Signal Input for U Phase High-side
5	$IN_{(UL)}$	Signal Input for U Phase Low-side
6	NC	No Connection
7	$V_{B(V)}$	Bias Voltage for V Phase High Side FRFET Driving
8	$V_{CC(V)}$	Bias Voltage for V Phase IC and Low Side FRFET Driving
9	$IN_{(VH)}$	Signal Input for V Phase High-side
10	$IN_{(VL)}$	Signal Input for V Phase Low-side
11	NC	No Connection
12	$V_{B(W)}$	Bias Voltage for W Phase High Side FRFET Driving
13	$V_{CC(W)}$	Bias Voltage for W Phase IC and Low Side FRFET Driving
14	$IN_{(WH)}$	Signal Input for W Phase High-side
15	$IN_{(WL)}$	Signal Input for W Phase Low-side
16	NC	No Connection
17	P	Positive DC-Link Input
18	U, $V_{S(U)}$	Output for U Phase & Bias Voltage Ground for High Side FRFET Driving
19	N_U	Negative DC-Link Input for U Phase
20	N_V	Negative DC-Link Input for V Phase
21	V, $V_{S(V)}$	Output for V Phase & Bias Voltage Ground for High Side FRFET Driving
22	N_W	Negative DC-Link Input for W Phase
23	W, $V_{S(W)}$	Output for W Phase & Bias Voltage Ground for High Side FRFET Driving

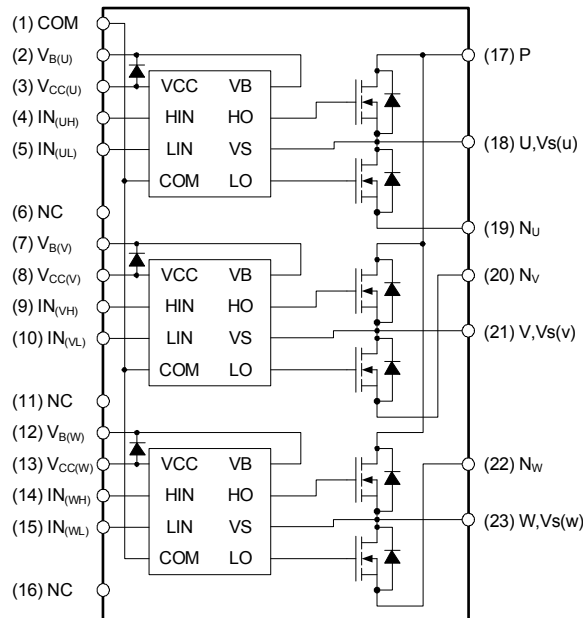

Note:

Source terminal of each low-side MOSFET is not connected to supply ground or bias voltage ground inside SPM®. External connections should be made as indicated in Figure 2 and 5.

Figure 1. Pin Configuration and Internal Block Diagram (Bottom View)

Electrical Characteristics (T_J = 25°C, V_{CC}=V_{BS}=15V Unless Otherwise Specified)

Inverter Part (Each FRFET Unless Otherwise Specified)

Symbol	Parameter	Conditions	Min	Typ	Max	Units
BV _{DSS}	Drain-Source Breakdown Voltage	V _{IN} = 0V, I _D = 250μA (Note 2)	500	-	-	V
ΔBV _{DSS} /ΔT _J	Breakdown Voltage Temperature Coefficient	I _D = 250μA, Referenced to 25°C	-	0.53	-	V
I _{DSS}	Zero Gate Voltage Drain Current	V _{IN} = 0V, V _{DS} = 500V	-	-	250	μA
R _{DS(on)}	Static Drain-Source On-Resistance	V _{CC} = V _{BS} = 15V, V _{IN} = 5V, I _D = 0.5A	-	3.5	4.2	Ω
V _{SD}	Drain-Source Diode Forward Voltage	V _{CC} = V _{BS} = 15V, V _{IN} = 0V, I _D = -0.5A	-	-	1.2	V
t _{ON}	Switching Times	V _{PN} = 300V, V _{CC} = V _{BS} = 15V, I _D = 0.5A V _{IN} = 0V ↔ 5V Inductive load L=3mH High- and low-side FRFET switching (Note 3)	-	1050	-	ns
t _{OFF}			-	850	-	ns
t _{rr}			-	170	-	ns
E _{ON}			-	40	-	μJ
E _{OFF}			-	10	-	μJ
RBSOA	Reverse-bias Safe Operating Area	V _{PN} = 400V, V _{CC} = V _{BS} = 15V, I _D = I _{DP} , V _{DS} =BV _{DSS} , T _J = 150°C High- and low-side FRFET switching (Note 4)	Full Square			

Control Part (Each HVIC Unless Otherwise Specified)

Symbol	Parameter	Conditions	Min	Typ	Max	Units
I _{QCC}	Quiescent V _{CC} Current	V _{CC} =15V, V _{IN} =0V Applied between V _{CC} and COM	-	-	160	μA
I _{QBS}	Quiescent V _{BS} Current	V _{BS} =15V, V _{IN} =0V Applied between V _{B(U)} -U, V _{B(V)} -V, V _{B(W)} -W	-	-	100	μA
UV _{CCD}	Low-side Undervoltage Protection (Figure 7)	V _{CC} Undervoltage Protection Detection Level	7.4	8.0	9.4	V
UV _{CCR}		V _{CC} Undervoltage Protection Reset Level	8.0	8.9	9.8	V
UV _{BSD}	High-side Undervoltage Protection (Figure 8)	V _{BS} Undervoltage Protection Detection Level	7.4	8.0	9.4	V
UV _{BSR}		V _{BS} Undervoltage Protection Reset Level	8.0	8.9	9.8	V
V _{IH}	ON Threshold Voltage	Logic High Level	2.9	-	-	V
V _{IL}	OFF Threshold Voltage	Logic Low Level				
I _{IH}	Input Bias Current	V _{IN} = 5V	-	10	20	μA
I _{IL}		V _{IN} = 0V	-	-	2	μA

Bootstrap Diode Part

Symbol	Parameter	Conditions	Rating	Units
V _{RRM}	Maximum Repetitive Reverse Voltage		500	V
I _F	Forward Current	T _C = 25°C	0.5	A
I _{FP}	Forward Current (Peak)	T _C = 25°C, Under 1ms Pulse Width	2	A
T _J	Operating Junction Temperature		-40 ~ 150	°C

Note:

- For the measurement point of case temperature T_C, please refer to Figure 4 in page 5.
- BV_{DSS} is the absolute maximum voltage rating between drain and source terminal of each FRFET inside SPM®. V_{PN} should be sufficiently less than this value considering the effect of the stray inductance so that V_{DS} should not exceed BV_{DSS} in any case.
- t_{ON} and t_{OFF} include the propagation delay time of the internal drive IC. Listed values are measured at the laboratory test condition, and they can be different according to the field applications due to the effect of different printed circuit boards and wirings. Please see Figure 5 for the switching time definition with the switching test circuit of Figure 6.
- The peak current and voltage of each FRFET during the switching operation should be included in the safe operating area (SOA). Please see Figure 6 for the RBSOA test circuit that is same as the switching test circuit.

Bootstrap Diode Part

Symbol	Parameter	Conditions	Min.	Typ.	Max.	Units
V_F	Forward Voltage	$I_F = 0.1A, T_C = 25^\circ C$	-	2.0	-	V
t_{rr}	Reverse Recovery Time	$I_F = 0.1A, T_C = 25^\circ C$	-	80	-	ns

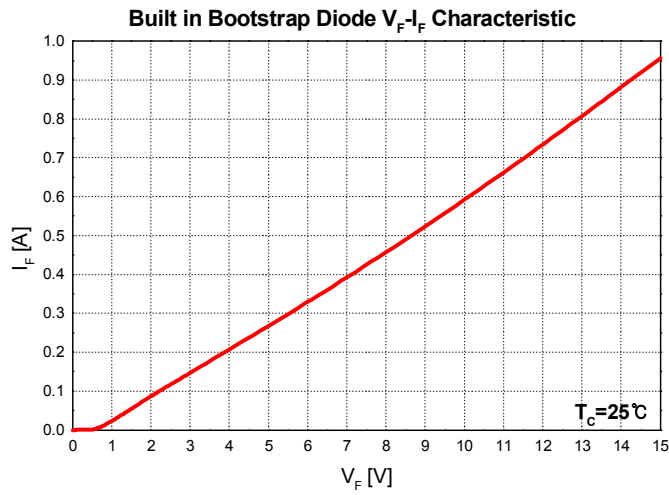

Note:

Built in bootstrap diode includes around 15Ω resistance characteristic.

Figure 2. Built in Bootstrap Diode Characteristics

Package Marking & Ordering Information

Device Marking	Device	Package	Reel Size	Packing Type	Quantity
FSB50250UTD	FSB50250UTD	SPM23-ED	-	-	15

Recommended Operating Conditions

Symbol	Parameter	Conditions	Value			Units
			Min.	Typ.	Max.	
V _{PN}	Supply Voltage	Applied between P and N	-	300	400	V
V _{CC}	Control Supply Voltage	Applied between V _{CC} and COM	13.5	15	16.5	V
V _{BS}	High-side Bias Voltage	Applied between V _B and output(U, V, W)	13.5	15	16.5	V
V _{IN(ON)}	Input ON Threshold Voltage	Applied between IN and COM	3.0	-	V _{CC}	V
V _{IN(OFF)}	Input OFF Threshold Voltage		0	-	0.6	V
t _{dead}	Blanking Time for Preventing Arm-short	V _{CC} =V _{BS} =13.5 ~ 16.5V, T _J ≤ 150°C	1.0	-	-	μs
f _{PWM}	PWM Switching Frequency	T _J ≤ 150°C	-	15	-	kHz

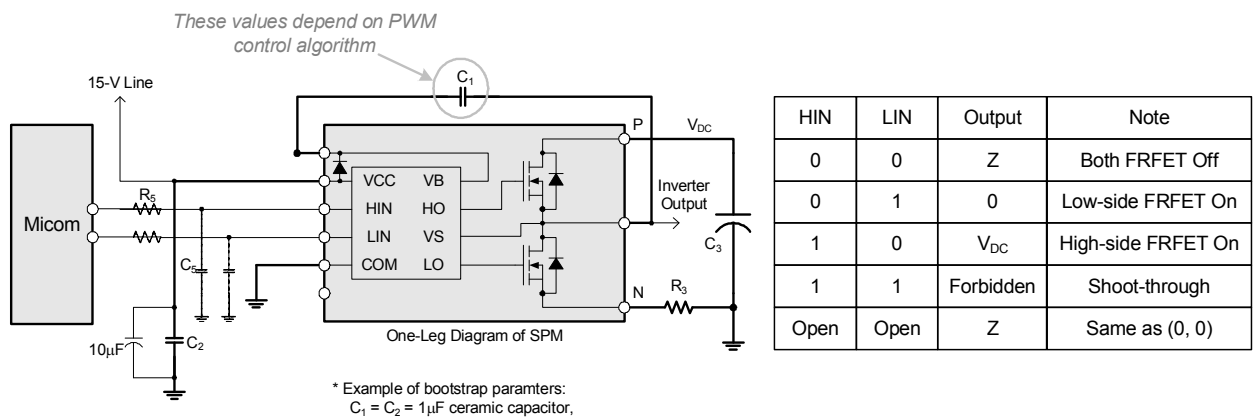

Note:

- (1) It is recommended the bootstrap diode D₁ to have soft and fast recovery characteristics with 500-V rating
- (2) Parameters for bootstrap circuit elements are dependent on PWM algorithm. For 15 kHz of switching frequency, typical example of parameters is shown above.
- (3) RC coupling(R_s and C_s) at each input (indicated as dotted lines) may be used to prevent improper input signal due to surge noise. Signal input of SPM® is compatible with standard CMOS or LSTTL outputs.
- (4) Bold lines should be short and thick in PCB pattern to have small stray inductance of circuit, which results in the reduction of surge voltage. Bypass capacitors such as C₁, C₂ and C₃ should have good high-frequency characteristics to absorb high-frequency ripple current.

Figure 3. Recommended CPU Interface and Bootstrap Circuit with Parameters

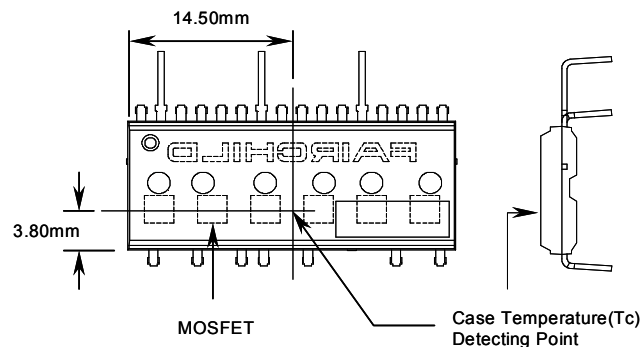

Note:

Attach the thermocouple on top of the heatsink-side of SPM® (between SPM® and heatsink if applied) to get the correct temperature measurement.

Figure 4. Case Temperature Measurement

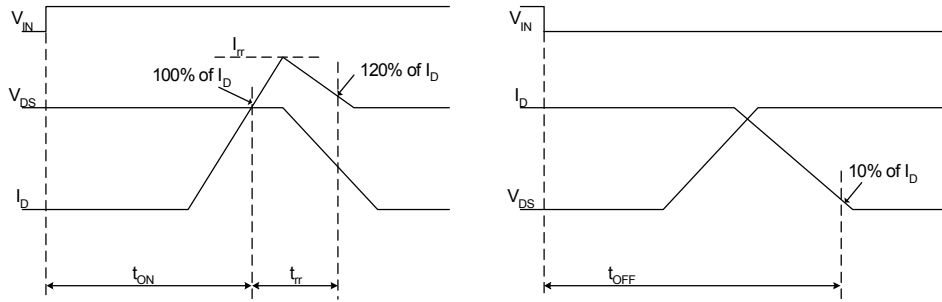

(a) Turn-on (b) Turn-off
Figure 5. Switching Time Definition

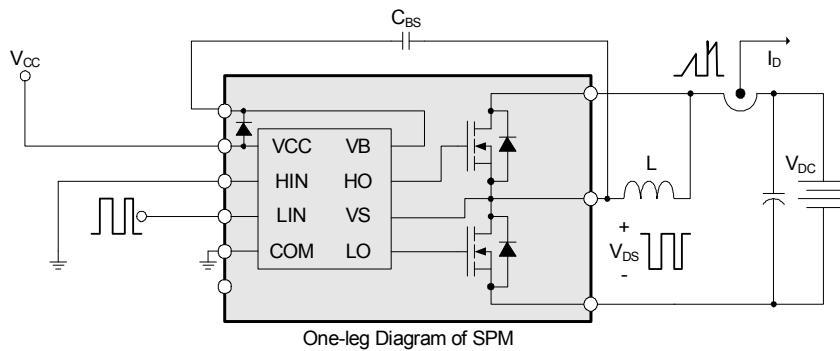

Figure 6. Switching and RBSOA(Single-pulse) Test Circuit (Low-side)

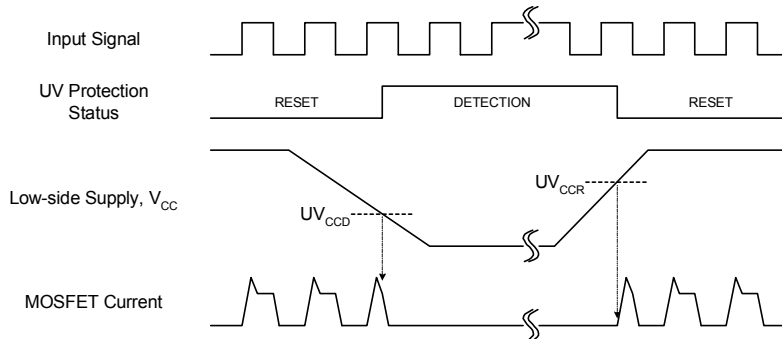

Figure 7. Undervoltage Protection (Low-side)

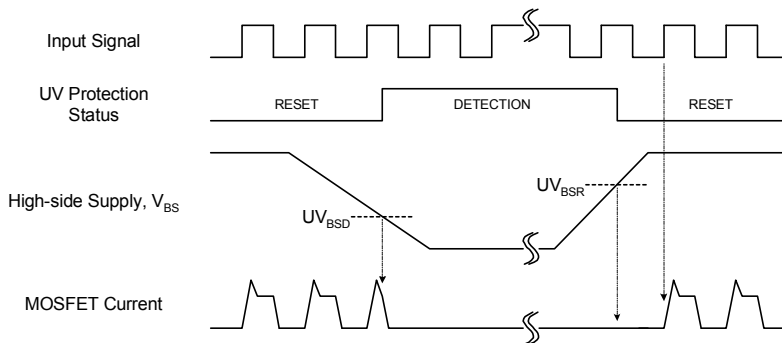

Figure 8. Undervoltage Protection (High-side)

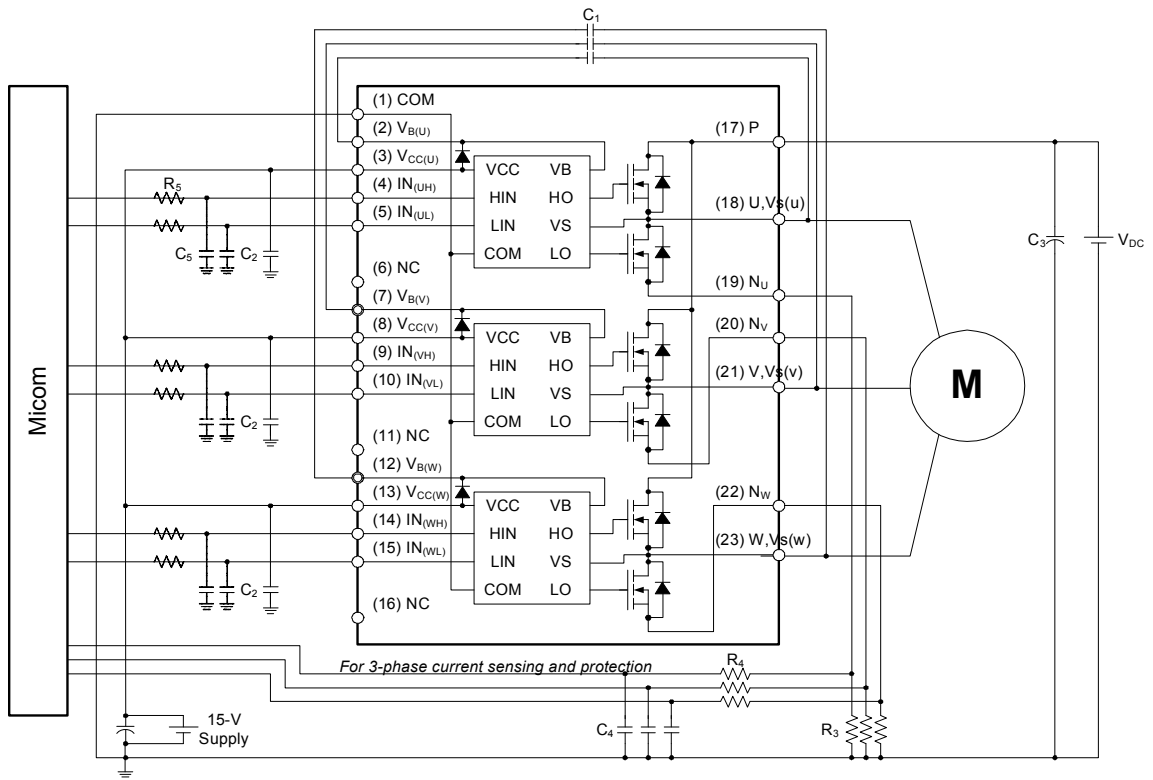

Figure 9. Example of Application Circuit



TRADEMARKS

The following includes registered and unregistered trademarks and service marks, owned by Fairchild Semiconductor and/or its global subsidiaries, and is not intended to be an exhaustive list of all such trademarks.

- | | | | |
|--------------------------|------------------------|---------------------------------------|---|
| AccuPower™ | F-PFS™ | Power-SPM™ | <p>SYSTEM GENERAL
The Power Franchise®</p> <p>the power franchise</p> <p>TinyBoost™
TinyBuck™
TinyCalc™
TinyLogic®
TINYOPTO™
TinyPower™
TinyPWM™
TinyWire™
TriFault Detect™
TRUECURRENT™
µSerDes™</p> <p>SerDes</p> <p>UHC®
Ultra FRFET™
UniFET™
VCX™
VisualMax™
XS™</p> |
| Auto-SPM™ | FRFET® | PowerTrench® | |
| Build it Now™ | Global Power Resource™ | PowerXS™ | |
| CorePLUSTM | Green FPST™ | Programmable Active Droop™ | |
| CorePOWER™ | Green FPST™ e-Series™ | QFET® | |
| CROSSVOLT™ | Gmax™ | QS™ | |
| CTL™ | GTO™ | Quiet Series™ | |
| Current Transfer Logic™ | IntelliMAX™ | RapidConfigure™ | |
| DEUXPEED® | ISOPLANAR™ | ™ | |
| Dual Cool™ | MegaBuck™ | Saving our world, 1mW/W/kW at a time™ | |
| EcoSPARK® | MICROCOUPLER™ | SignalWise™ | |
| EfficientMax™ | MicroFET™ | SmartMax™ | |
| ESBC™ | MicroPak™ | SMART START™ | |
| ™ | MicroPak2™ | SPM® | |
| Fairchild® | MillerDrive™ | STEALTH™ | |
| Fairchild Semiconductor® | MotionMax™ | SuperFET™ | |
| FACT Quiet Series™ | Motion-SPM™ | SuperSOT™-3 | |
| FACT® | OptoHIT™ | SuperSOT™-6 | |
| FAST® | OPTOLOGIC® | SuperSOT™-8 | |
| FastvCore™ | OPTOPLANAR® | SupreMOS® | |
| FETBench™ | ™ | SyncFET™ | |
| FlashWriter® | PDP SPM™ | Sync-Lock™ | |
| FPS™ | | | |

* Trademarks of System General Corporation, used under license by Fairchild Semiconductor.

DISCLAIMER

FAIRCHILD SEMICONDUCTOR RESERVES THE RIGHT TO MAKE CHANGES WITHOUT FURTHER NOTICE TO ANY PRODUCTS HEREIN TO IMPROVE RELIABILITY, FUNCTION, OR DESIGN. FAIRCHILD DOES NOT ASSUME ANY LIABILITY ARISING OUT OF THE APPLICATION OR USE OF ANY PRODUCT OR CIRCUIT DESCRIBED HEREIN; NEITHER DOES IT CONVEY ANY LICENSE UNDER ITS PATENT RIGHTS, NOR THE RIGHTS OF OTHERS. THESE SPECIFICATIONS DO NOT EXPAND THE TERMS OF FAIRCHILD'S WORLDWIDE TERMS AND CONDITIONS, SPECIFICALLY, WARRANTY THEREIN, WHICH COVERS THESE PRODUCTS.

LIFE SUPPORT POLICY

FAIRCHILD'S PRODUCTS ARE NOT AUTHORIZED FOR USE AS CRITICAL COMPONENTS IN LIFE SUPPORT DEVICES OR SYSTEMS WITHOUT THE EXPRESS WRITTEN APPROVAL OF FAIRCHILD SEMICONDUCTOR CORPORATION.

As used herein:

1. Life support devices or systems are devices or systems which, (a) are intended for surgical implant into the body or (b) support or sustain life, and (c) whose failure to perform when properly used in accordance with instructions for use provided in the labeling, can be reasonably expected to result in a significant injury of the user.
2. A critical component in any component of a life support, device, or system whose failure to perform can be reasonably expected to cause the failure of the life support device or system, or to affect its safety or effectiveness.

ANTI-COUNTERFEITING POLICY

Fairchild Semiconductor Corporation's Anti-Counterfeiting Policy. Fairchild's Anti-Counterfeiting Policy is also stated on our external website, www.fairchildsemi.com, under Sales Support.

Counterfeiting of semiconductor parts is a growing problem in the industry. All manufacturers of semiconductor products are experiencing counterfeiting of their parts. Customers who inadvertently purchase counterfeit parts experience many problems such as loss of brand reputation, substandard performance, failed applications, and increased cost of production and manufacturing delays. Fairchild is taking strong measures to protect ourselves and our customers from the proliferation of counterfeit parts. Fairchild strongly encourages customers to purchase Fairchild parts either directly from Fairchild or from Authorized Fairchild Distributors who are listed by country on our web page cited above. Products customers buy either from Fairchild directly or from Authorized Fairchild Distributors are genuine parts, have full traceability, meet Fairchild's quality standards for handling and storage and provide access to Fairchild's full range of up-to-date technical and product information. Fairchild and our Authorized Distributors will stand behind all warranties and will appropriately address any warranty issues that may arise. Fairchild will not provide any warranty coverage or other assistance for parts bought from Unauthorized Sources. Fairchild is committed to combat this global problem and encourage our customers to do their part in stopping this practice by buying direct or from authorized distributors.

PRODUCT STATUS DEFINITIONS

Definition of Terms

Datasheet Identification	Product Status	Definition
Advance Information	Formative / In Design	Datasheet contains the design specifications for product development. Specifications may change in any manner without notice.
Preliminary	First Production	Datasheet contains preliminary data; supplementary data will be published at a later date. Fairchild Semiconductor reserves the right to make changes at any time without notice to improve design.
No Identification Needed	Full Production	Datasheet contains final specifications. Fairchild Semiconductor reserves the right to make changes at any time without notice to improve the design.
Obsolete	Not In Production	Datasheet contains specifications on a product that is discontinued by Fairchild Semiconductor. The datasheet is for reference information only.

Rev. 149