

THIS DRAWING IS THE PROPERTY OF FAIRCHILD SEMICONDUCTOR CORPORATION. NO USE THEREOF SHALL BE MADE OTHER THAN AS A REFERENCE FOR PROPOSALS AS SUBMITTED TO FAIRCHILD SEMICONDUCTOR CORPORATION FOR JOBS TO BE EXECUTED IN CONFORMANCE WITH SUCH PROPOSALS UNLESS THE CONSENT OF SAID FAIRCHILD SEMICONDUCTOR CORPORATION HAS PREVIOUSLY BEEN OBTAINED. NO PART OF THIS DRAWING SHALL BE COPIED OR DUPLICATED OR ITS CONTENTS DISCLOSED. THE INFORMATION CONTAINED ON THIS DRAWING IS CONFIDENTIAL AND PROPRIETARY.

APPROVED
October 10, 2008

REVISIONS			
LTR	DESCRIPTION	DATE	NAME/SITE
F	REVISE & REDRAW PER CURRENT STDA; ADD LAND PATTERN	NOV.30,1995	TL
G	ADD 0.004 (0.10) COPLANARITY; NOTE 1: 200 WAS 150; 5.08 WAS 3.81.	FEB.23,1998	MS
H	CHG DWG TEMPL FR NSC TO FSC; CHG DIM STD FR DUAL TO SINGLE; CHG PKG LEN DIM FR 2.82+/-0.13 TO 2.92+/-0.20; CHG PKG WID FR 1.30+/-0.10 TO 1.30+0.20/-0.15; CHG TOT PKG THIC FR 0.88-1.08 TO 1.30 MAX; CHG PROFILE FR 0.013-0.103 TO 0.00-0.10; CHG LD THIC FR 0.13+/-0.05 TO 0.08-0.23; CHG LD WID FR 0.445+/-0.084 TO 0.37-0.60; CHG LD PITCH FR 0.933+/-0.084 TO 0.95 BSC; CHG TOT LD PITCH FR 1.91+/-0.13 TO 1.90 BSC; CHG LAND PATTERN DIM FR 0.762 TYP TO 1.00, FR 0.762 TYP TO 1.40; FR 2.286 TYP TO 2.00; ADDED DIM (0.29); CHG NOTE A FR "STD LD FINISH SPEC" TO "JEDEC REF"; CHG NOTE B FR "JEDEC REF" TO "DIM REF"; ADDED NOTE C&D; ADD LD POS TOL	12AUG2003	MRG
9	CHG DRW NO FR MKT-M03B TO MKT-MA03D.	28 JULY 2008	MRG/CB

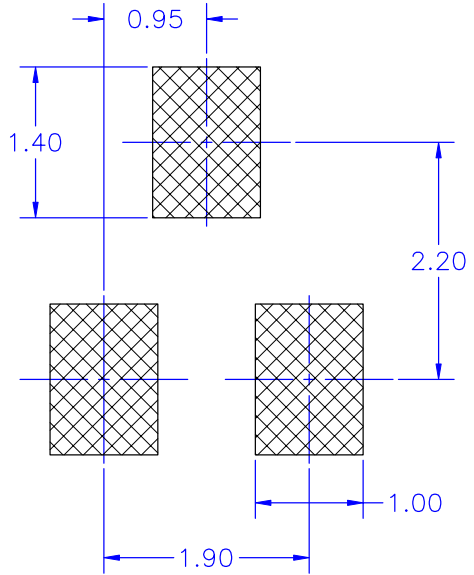
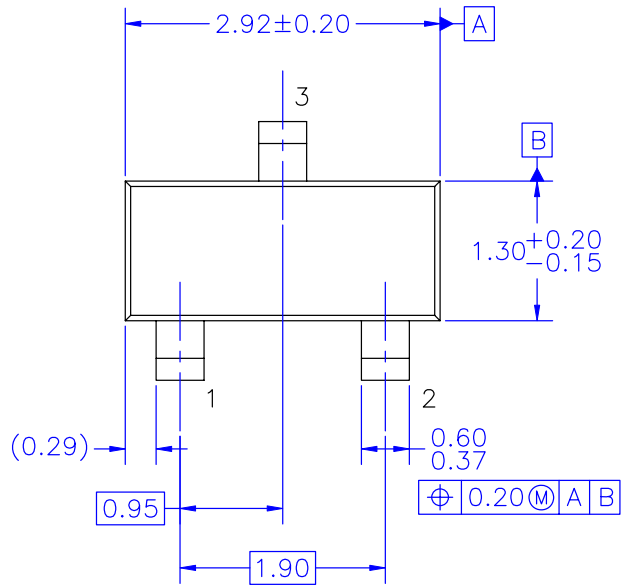

LAND PATTERN RECOMMENDATION

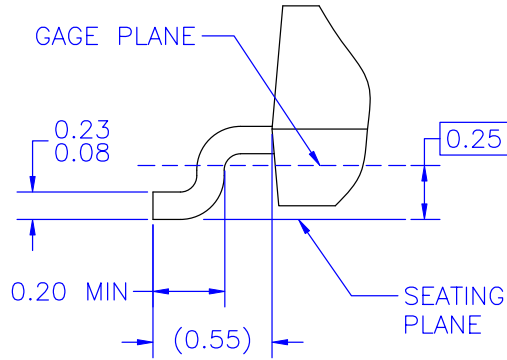
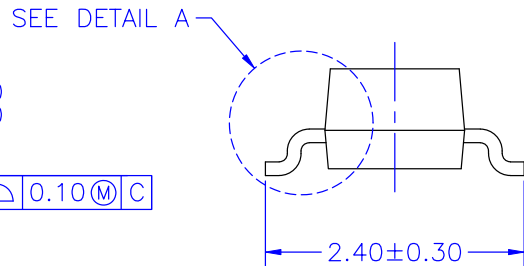
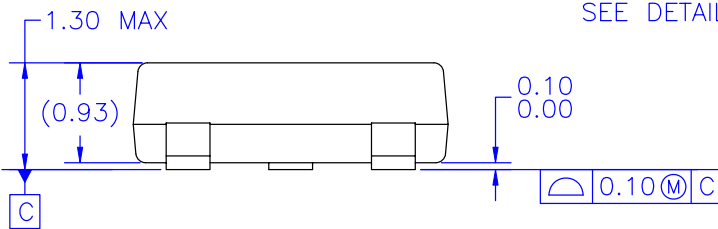

DETAIL A
SCALE: 2X

NOTES: UNLESS OTHERWISE SPECIFIED

- A) REFERENCE JEDEC REGISTRATION TO-236, VARIATION AB, ISSUE H.
- B) ALL DIMENSIONS ARE IN MILLIMETERS.
- C) DIMENSIONS ARE INCLUSIVE OF BURRS, MOLD FLASH AND TIE BAR EXTRUSIONS.
- D) DIMENSIONING AND TOLERANCING PER ASME Y14.5M - 1994.
- E) DRAWING FILE NAME: MA03DREV9

APPROVALS	DATE	FAIRCHILD SEMICONDUCTOR™
DRAWN: J.U. COMPARATIVO JR.	07AUG2008	
CHECKED: L. GALERA		
APPROVED: M. GESTOLE		
G.S. BAJE		3LD, SOT23, JEDEC TO-236, LOW PROFILE
PROJECTION 		SCALE: 1:1
INCH (MM)		DRAWING NUMBER: MKT-MA03D
FORMERLY: N/A		REV: 9
SHEET : 1 OF 1		