

REVISIONS				
LTR	DESCRIPTION	E.C.N.	DATE	BY/APPD
A	RELEASE TO DOCUMENT CONTROL	ECN-MKT-MA06E	11/4/2006	H.ALLEN
2	DWG UPDATED TO CONFORM TO MO178		5 JULY 07	L.HUEBENER

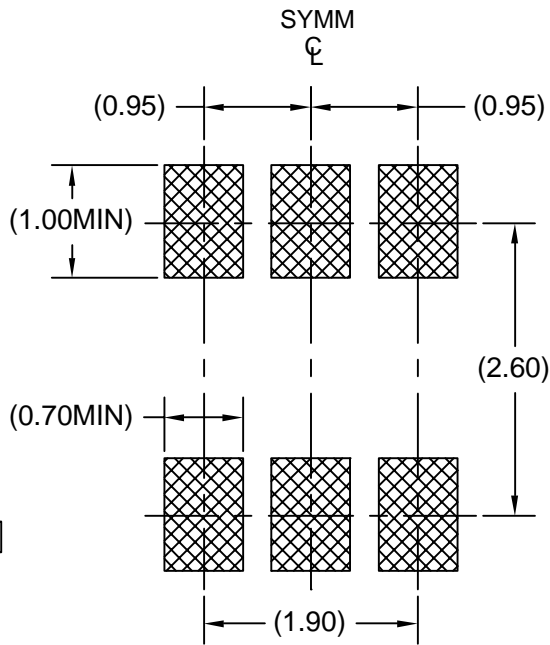

LAND PATTERN RECOMMENDATION

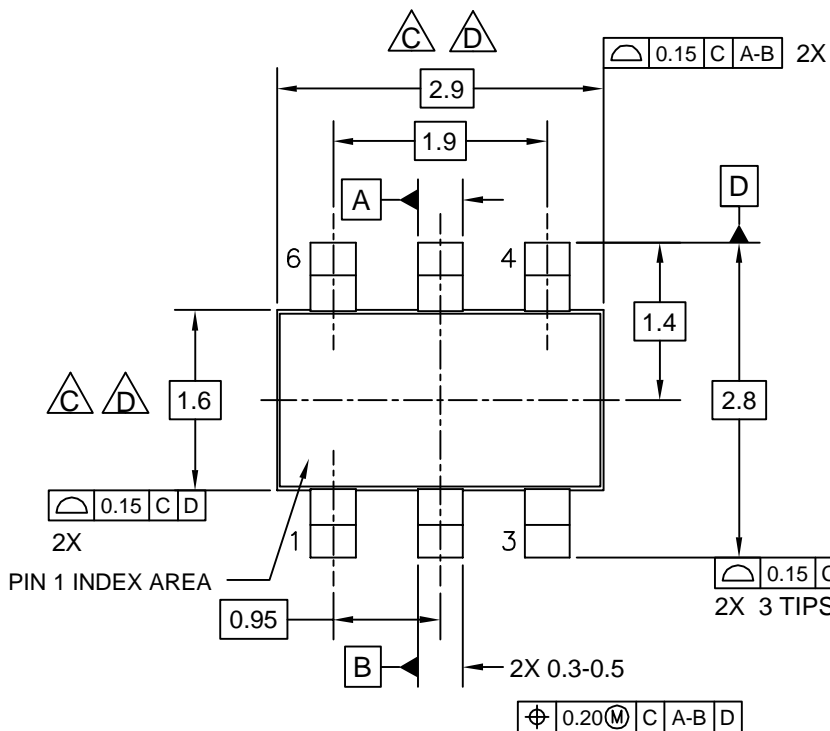
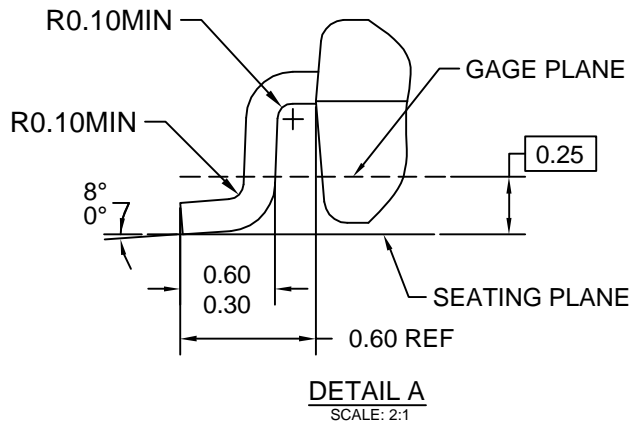
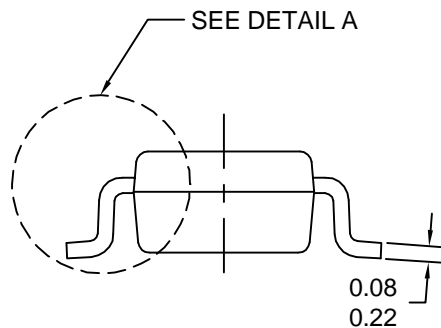
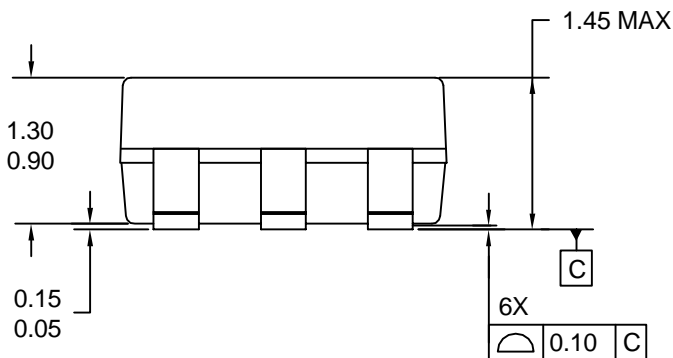

NOTES:

- A. THIS PACKAGE CONFORMS TO JEDEC MO-178, VARIATION AB.
- B. ALL DIMENSIONS ARE IN MILLIMETERS.
- C. DOES NOT INCLUDE MOLD FLASH, PROTRUSIONS OR GATE BURRS.
- D. DOES NOT INCLUDE INTERLEAD FLASH OR PROTRUSIONS.
- E. DIMENSIONS AND TOLERANCING AS PER ASME Y14.5M-1994
- F. DRAWING FILE NAME: MA06EREV2

APPROVALS		DATE	
DRAWN: L.HUEBENER		5 JULY 07	
CHECKED: H.ALLEN		17 JULY 07	
APPROVED:			
			6LD,SOT23,JEDEC MO-178 VARIATION AB, 1.6MM WIDE
			SCALE: 1:1 SIZE: NA DRAWING NUMBER: MKT-MA06E FORMERLY: N/A
		REV: 2	SHEET: 1 OF 1