

REVISIONS

LTR	DESCRIPTION	EDCN	DATE	BY/APP'D
A	RELEASE TO DOCUMENT CONTROL	MASS ECN UPDATE	10/4/2006	H.ALLEN
2	1.0mm original dim. covered both Carsem of 1.0mm max and Pg at 0.8mm max. Carsem has been dropped as a subcon for the package and customers want a drawing reflecting the actual max of 0.8mm		09/02/2007	H.ALLEN

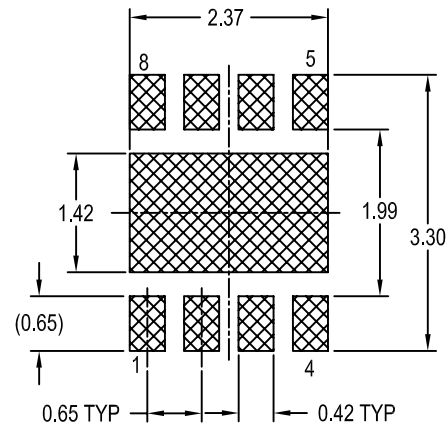
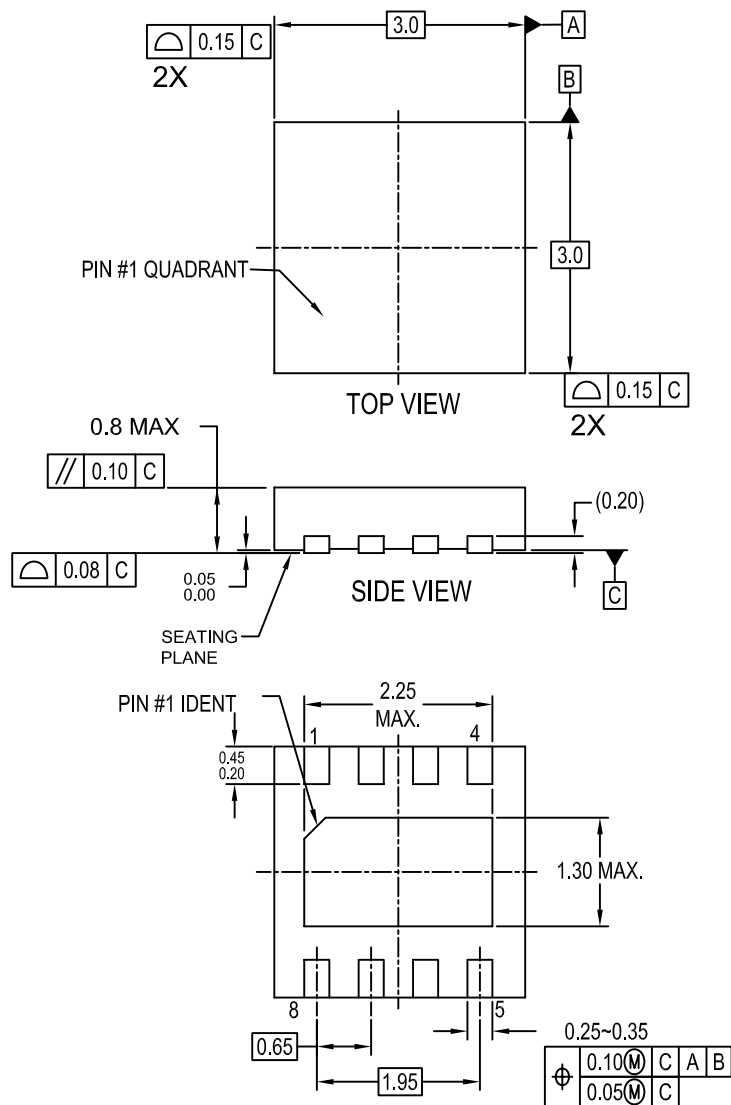

RECOMMENDED LAND PATTERN

- NOTES:
- A. CONFORMS TO JEDEC REGISTRATION MO-229, VARIATION VEEC, DATED 11/2001
 - B. DIMENSIONS ARE IN MILLIMETERS.
 - C. DIMENSIONS AND TOLERANCES PER ASME Y14.5M, 1994
 - D. FILENAME: MKT-MLP08Drev2

BOTTOM VIEW

MLP08Drev2

APPROVALS	DATE	FAIRCHILD SEMICONDUCTOR			
DRAWN h.allen	09-02-07	Bayan Lepas, FIZ, 11900, Penang, Malaysia.			
DFTG. CHK.		8LD,MLP DUAL,JEDEC MO-229, 3MM SQUARE			
ENGR. CHK. J Chan	26-02-07				
PROJECTION		SCALE	SIZE	DRAWING NUMBER	REV
		N/A	N/A	MKT-MLP08D	2
DO NOT SCALE DRAWING				SHEET 1 of 1	