

**REVISIONS**

LTR	DESCRIPTION	DATE	BY/APPD
A	RELEASE TO MARKETING	01/24/2002	S.KONG
2	DRAWING RECREATED & UPDATED TO MKT-0001	22 AUG 07	L.HUEBENER

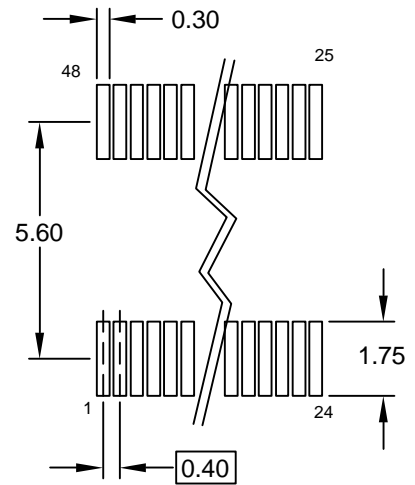

⌀ 0.178 (M) C A-B D

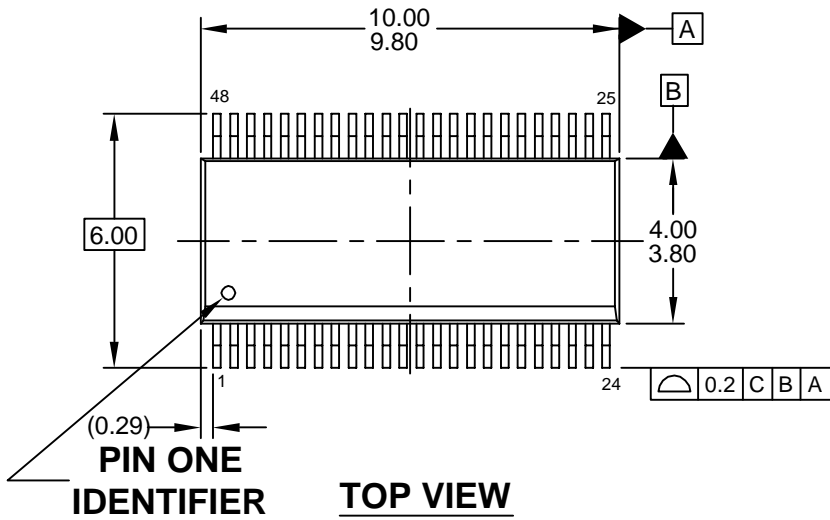
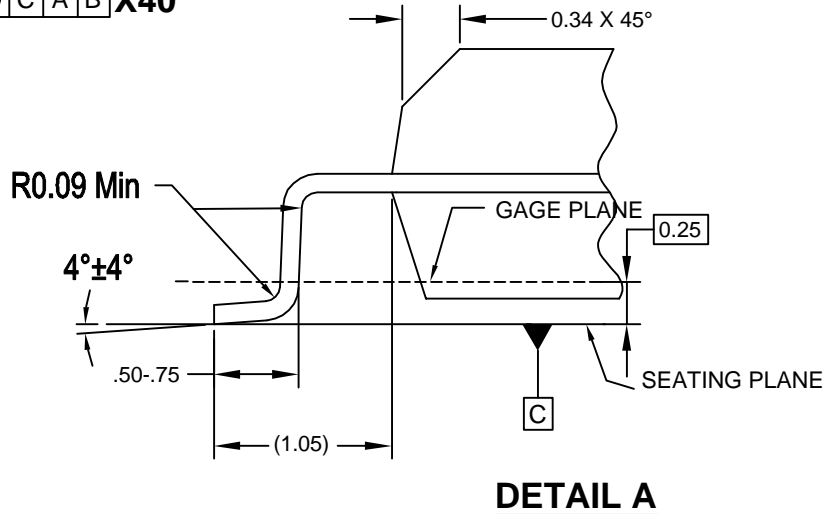
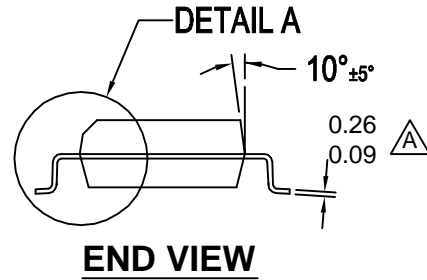
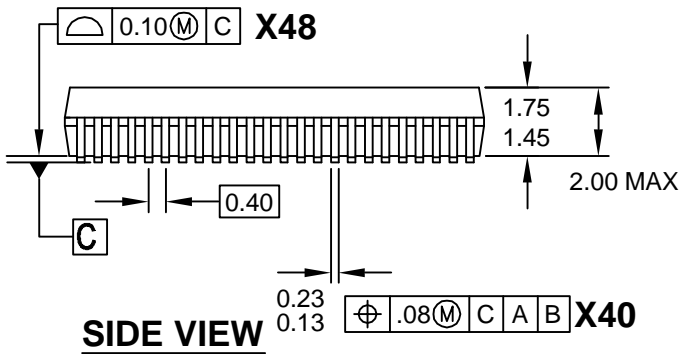

**NOTES : UNLESS OTHERWISE NOTED**

- A. THIS PACKAGE CONFORMS TO JEDEC M0-154 VARIATION AB
- B. ALL DIMENSIONS ARE IN MILLIMETERS
- C. DRAWING CONFORMS TO ASME Y14.5M-1994
- D. DIMENSIONS ARE EXCLUSIVE OF BURRS, MOLD FLASH, AND TIE BAR EXTRUSIONS
- E. LAND PATTERN STANDARD: SOP50P600X200-40M
- F. DRAWING FILE NAME: MQA48AREV2

APPROVALS	DATE	FAIRCHILD SEMICONDUCTOR
DRAWN L.HUEBENER	22 AUG 07	
DFTG. CHK.		
ENGR. CHK.		
		SCALE N/A
		SIZE N/A
		DRAWING NUMBER MKT-MQA48A
		REV 2
		DO NOT SCALE DRAWING
		SHEET 1 of 1