

REVISIONS

LTR	DESCRIPTION	EDCN	DATE	BY/APP'D
2	RECREATED DRAWING	ECN-MKT-MSA28R2	17 JULY 07	L.HUEBENER

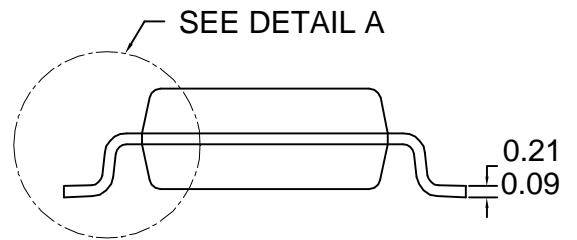
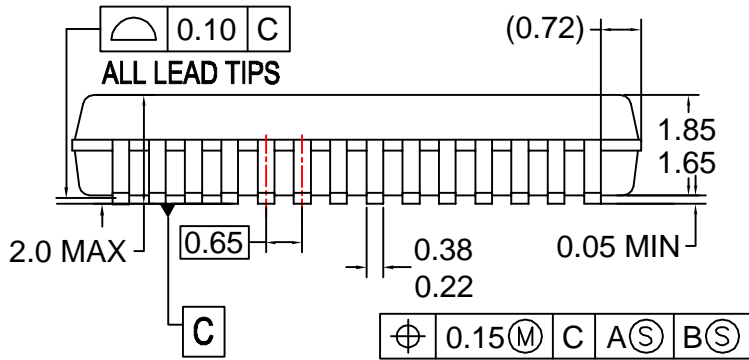
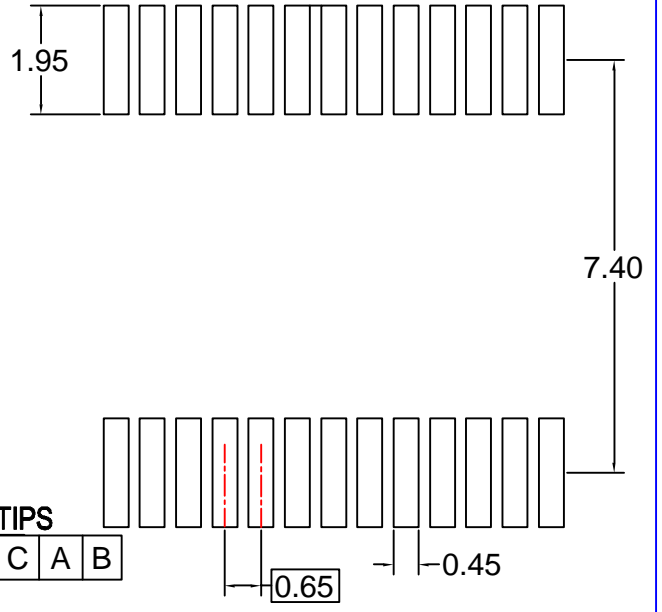
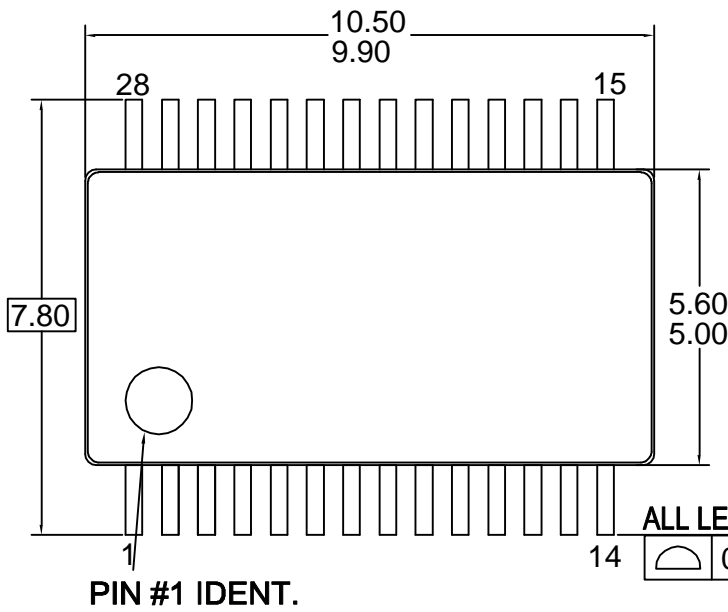

NOTES:

- A. CONFORMS TO JEDEC REGISTRATION MO-150, VARIATION AH.
- B. DIMENSIONS ARE IN MILLIMETERS.
- C. DIMENSIONS ARE EXCLUSIVE OF BURRS, MOLD FLASH, AND TIE BAR EXTRUSIONS.
- D. DIMENSIONS AND TOLERANCES PER ASME Y14.5M - 1994.
- E. LANDPATTERN STANDARD: SOP65P780X200-28M
- F. DRAWING FILE NAME: MKT-MSA28REV2

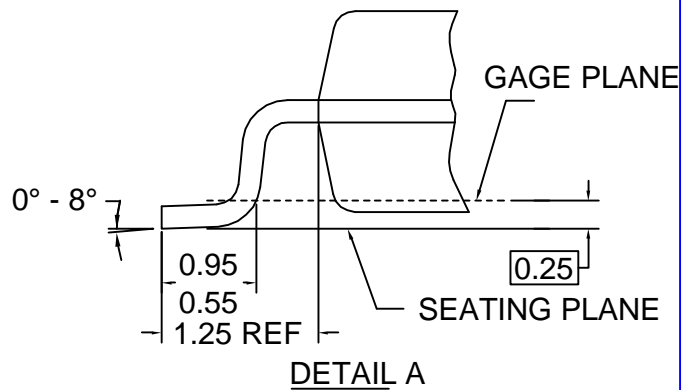

APPROVALS	DATE	FAIRCHILD SEMICONDUCTOR			
DRAWN: L.HUEBENER	17 JULY 07	28LD, SSOP, JEDEC MO-150, 5.3MM WIDE			
DFTG. CHK: H.ALLEN	1 AUG 07				
ENGR. CHK:					
		SCALE: N/A	SIZE: C	DRAWING NUMBER: MKT-MSA28	REV: 2
		DO NOT SCALE DRAWING		SHEET 1 of 1	