

REVISIONS			
Ltr	Description	Date	DRAWN/SITE
0	RELEASED PER ECN K-12158	08-09-99	JOSEPH
1	UPDATE QT LOGO PER ECN K-12648	09-13-00	JOSEPH
2	UPDATE FAIRCHILD LOGO PER ECN K-13836	01-10-04	JAYASELAN
3	CONVERT ESP-4004-01 TO FSC STANDARD DWG.	13-08-08	WEE LING

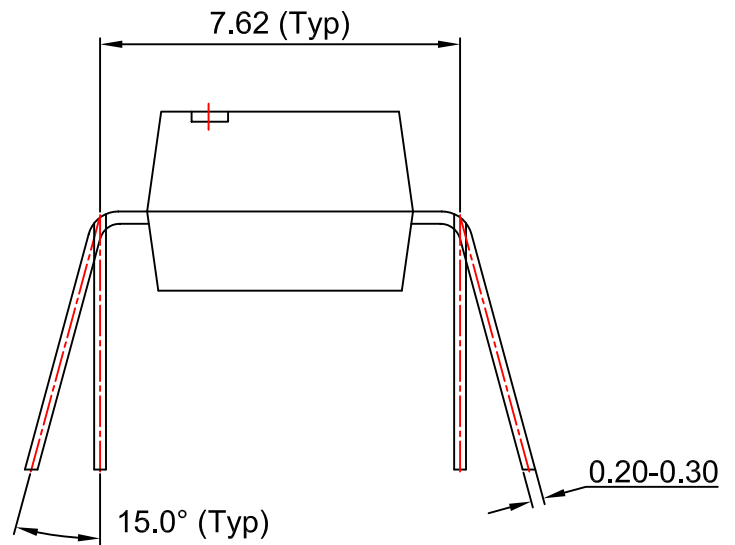
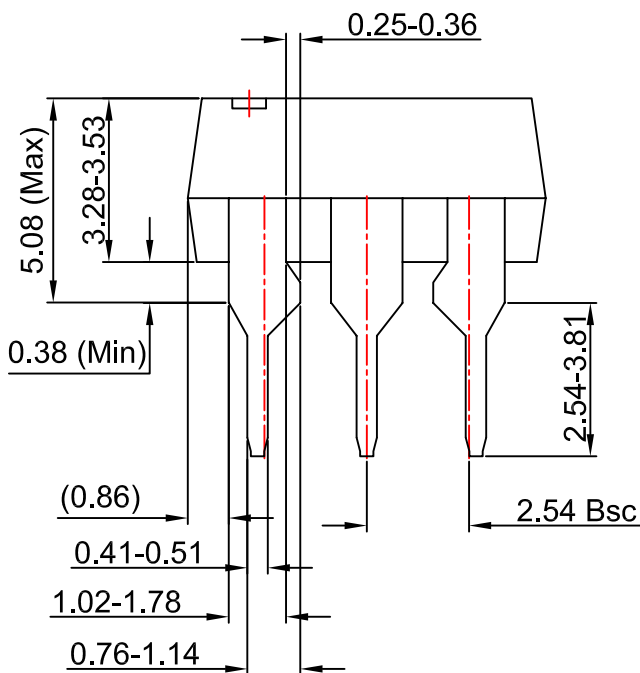
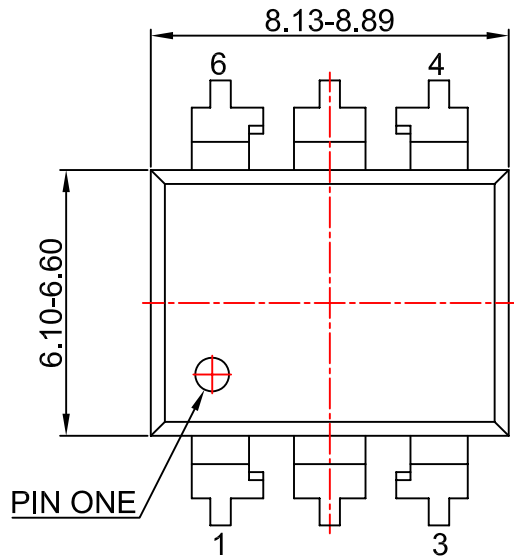

NOTES:

- A) NO STANDARD APPLIES TO THIS PACKAGE.
- B) ALL DIMENSIONS ARE IN MILLIMETERS.
- C) DIMENSIONS ARE EXCLUSIVE OF BURRS, MOLD FLASH, AND TIE BAR EXTRUSION
- D) DRAWING FILENAME AND REVISION: MKT-N06BREV3.

APPROVALS	DATE	FAIRCHILD SEMICONDUCTOR			
DRAWN: WEE LING	13 Aug 08	6LD,MDIP, OPTO,WHITE, .300 WIDE			
DFTG. CHK: JING ALABIN	13 Aug 08				
ENGR. CHK: JING ALABIN	13 Aug 08				
		SCALE: N/A	SIZE: N/A	DRAWING NUMBER: MKT-N06B	REV: 3
		DO NOT SCALE DRAWING SHEET 1 of 1			