

THIS DRAWING IS THE PROPERTY OF FAIRCHILD SEMICONDUCTOR CORPORATION. NO USE THEREOF SHALL BE MADE OTHER THAN AS A REFERENCE FOR PROPOSALS AS SUBMITTED TO FAIRCHILD SEMICONDUCTOR CORPORATION FOR JOBS TO BE EXECUTED IN CONFORMANCE WITH SUCH PROPOSALS UNLESS THE CONSENT OF SAID FAIRCHILD SEMICONDUCTOR CORPORATION HAS PREVIOUSLY BEEN OBTAINED. NO PART OF THIS DRAWING SHALL BE COPIED OR DUPLICATED OR ITS CONTENTS DISCLOSED. THE INFORMATION CONTAINED ON THIS DRAWING IS CONFIDENTIAL AND PROPRIETARY.

REVISIONS			
LTR	DESCRIPTION	DATE	NAME/SITE
A	RELEASE TO DOCUMENT CONTROL	13FEB08	JJM/FSCP
2	CHG BUMP HT FR 0.21+0.025 MAX; CHG BALL DIA FR 0.27±0.025 TO 0.265±0.025	09JUL08	JJM/FSCP

**APPROVED**  
August 23, 2008

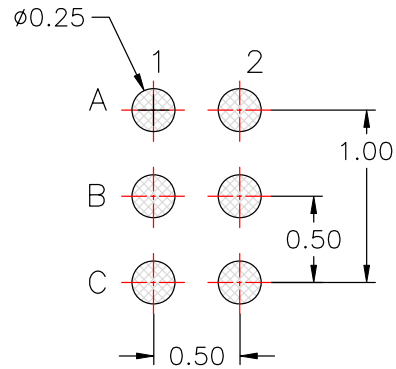
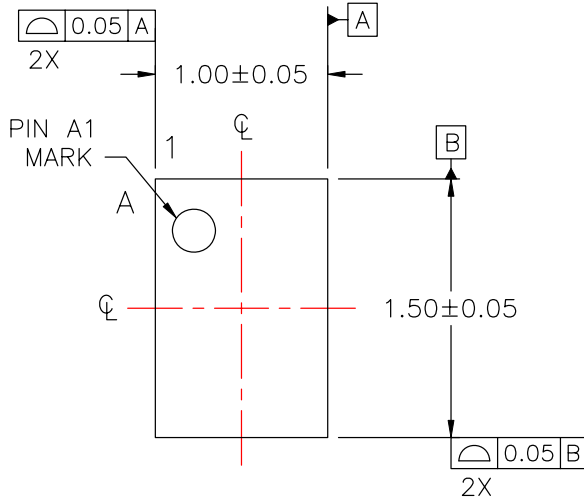

LAND PATTERN RECOMMENDATION

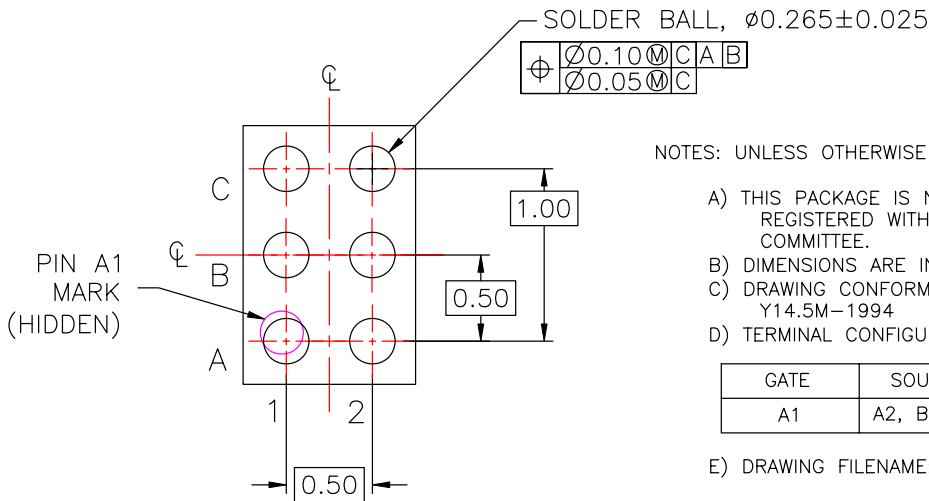
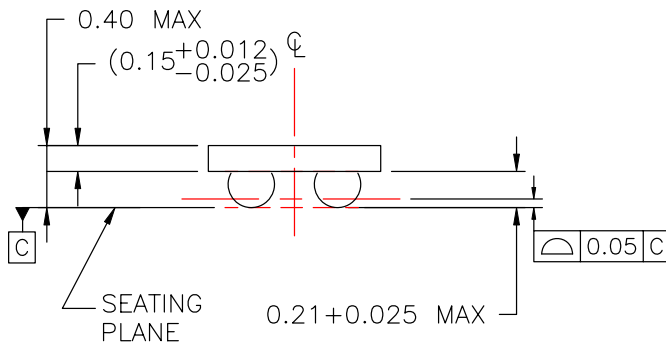

NOTES: UNLESS OTHERWISE SPECIFIED

- A) THIS PACKAGE IS NOT PRESENTLY REGISTERED WITH ANY STANDARDS COMMITTEE.
- B) DIMENSIONS ARE IN MILLIMETERS.
- C) DRAWING CONFORMS TO ASME Y14.5M-1994
- D) TERMINAL CONFIGURATION TABLE:

GATE	SOURCE	DRAIN
A1	A2, B1, B2	C1, C2

E) DRAWING FILENAME: MKT-UC006AEREV2

APPROVALS		DATE			
DRAWN: J.U. COMPARATIVO JR. CHECKED: J.V.J. MANCELITA APPROVED: M.R. GESTOLE G.S. BAJE		09JUL2008			<b>6BALL, WLCSP</b> <b>1.0X1.5X0.4MM, THIN</b>
PROJECTION			SCALE 1:1	SIZE DRAWING NUMBER MKT-UC006AE	
FORMERLY: N/A			SHEET : 1 OF 1		