

22-SOP-300 Tape and Reel Data

FAIRCHILD
SEMICONDUCTOR®

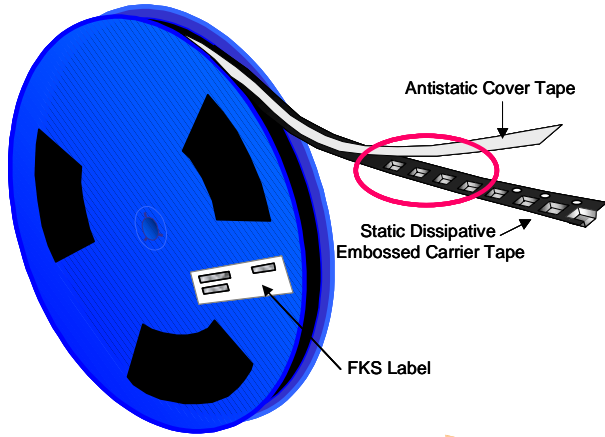

Packaging Description:
22-SOP-300 parts are shipped normally in tape. The carrier tape is made from a dissipative (carbon filled) polycarbonate resin. The cover tape is a multilayer film (Heat Activated Adhesive in nature) primarily composed of polyester film, adhesive layer, sealant, and anti-static sprayed agent. These reeled parts in standard option are shipped with 1,000 units per 13" or 330cm diameter reel. The reels are dark blue or black in color and is made of polystyrene plastic (anti-static coated). This and some other options are further described in the Packaging Information table. These full reels are individually barcode labeled and placed inside a standard intermediate box (illustrated in figure 1.0) made of recyclable corrugated brown paper. One box contains two reels maximum. And these boxes are placed inside a barcode labeled shipping box which comes in different sizes depending on the number of parts shipped.

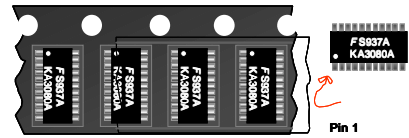

22-SOP-300 Packaging Information		
Packaging Option	Standard (no flow code)	-
Packaging type	TNR	Rail/Tube
Qty per Reel/Tube/Bag	1,000	30
Reel Size	13" Dia	-
Inner Box Dimension (mm)	339x352x68	520x90x55
Max qty per Box	2,000	2,100
Outer Box Dimension (mm)	385x363x363	554x308x223
Max qty per Box	10,000	21,000
Weight per unit (gm)	0.3115	0.3115
Weight per Reel (kg)	-	-
Note/Comments		

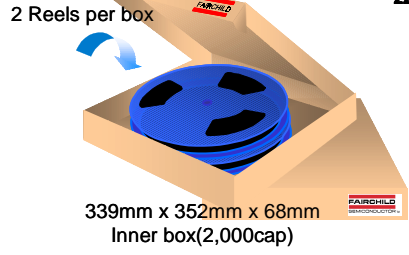

22-SOP-300 Unit Orientation

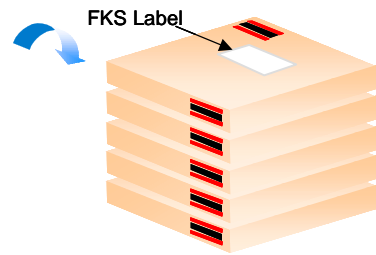

Inner Box Barcode Label Sample

MBB: NOR PPU: 000 P 00 / 03 / 17
 S/T: LOGO RB: LOGO ETC: 08:30
 HIC: 0 P/T: 0 MDC: X
 DVC: KA7812-AE
 LOT: TKLEE777 QTY: 1000 WW: 0103 01
 OPTION: 20000025

Outer Box Barcode Label Sample

DVC: KA7812-AE 00 / 03 / 17
 LOT: MMSYS777 IM 01 07:30
 QTY: 12000
 A710103105 88708892 7103

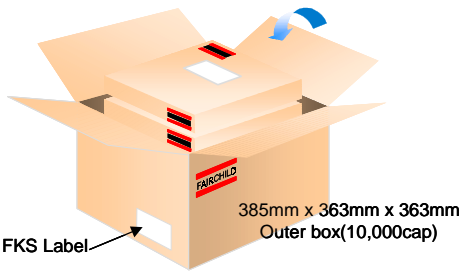

22-SOP-300 Tape Leader and Trailer Configuration: Figure 2.0

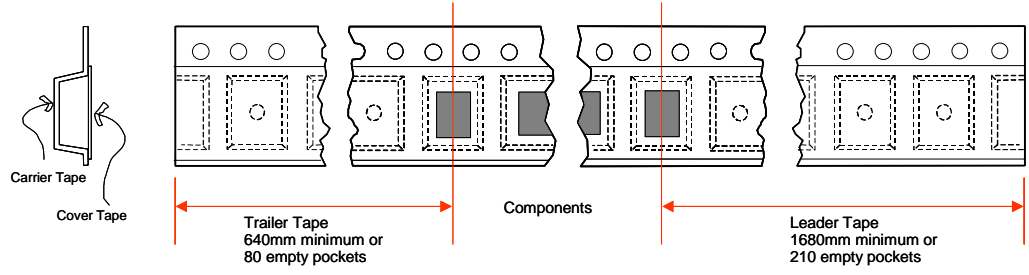

22-SOP-300 Tape and Reel Data, continued

22-SOP-300 Embossed Carrier Tape
Configuration: Figure 3.0

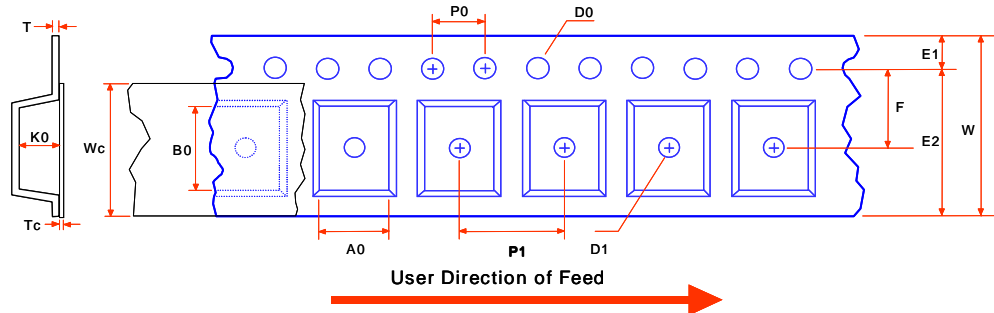

Dimensions are in millimeter														
Pkg type	A0	B0	W	D0	D1	E1	E2	F	P1	P0	K0	T	Wc	Tc
22SOP300 (24mm)	8.40 ±0.10	14.40 ±0.10	24.0 ±0.3	1.5 +0.10 -0.00	1.50 min	1.75 ±0.10	22.25 min	11.50 ±0.10	12.0 ±0.1	4.0 ±0.1	2.60 ±0.10	0.30 ±0.05	21.3 ±0.1	0.10 max

Notes: A0, B0, and K0 dimensions are determined with respect to the EIA/Jedec RS-481 rotational and lateral movement requirements (see sketches A, B, and C).

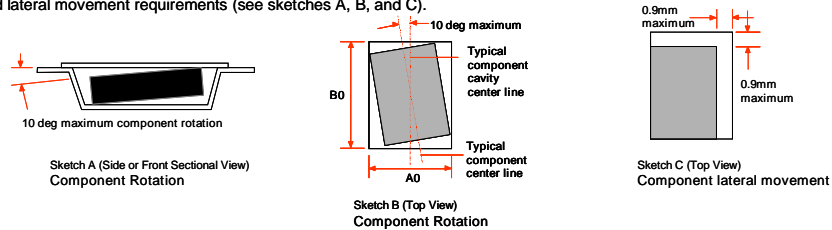

22-SOP-300 Reel Configuration: Figure 4.0

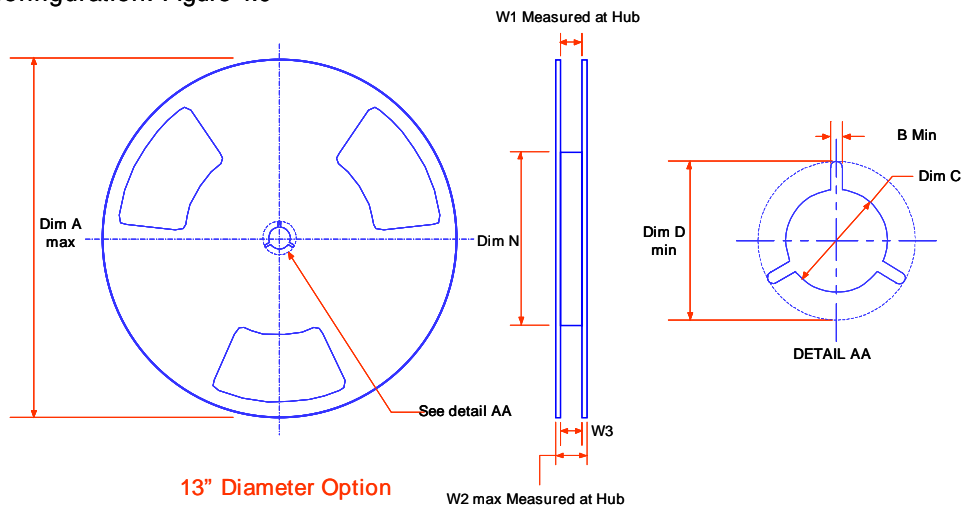

Dimensions are in inches and millimeters									
Tape Size	Reel Option	Dim A	Dim B	Dim C	Dim D	Dim N	Dim W1	Dim W2	Dim W3 (LSL-USL)
24.0mm	13" Dia	13.00 330	0.059 1.5	0.512 +0.020/-0.008 13 +0.5/-0.2	0.795 20.2	4.00 100	0.960 +0.078/-0.000 24.4 +2/0	1.196 30.4	0.940 - 1.078 23.9 - 27.4

22-SOP-300 Tape and Reel Data

22-SOP-300 Tube Packing
Configuration: Figure 5.0

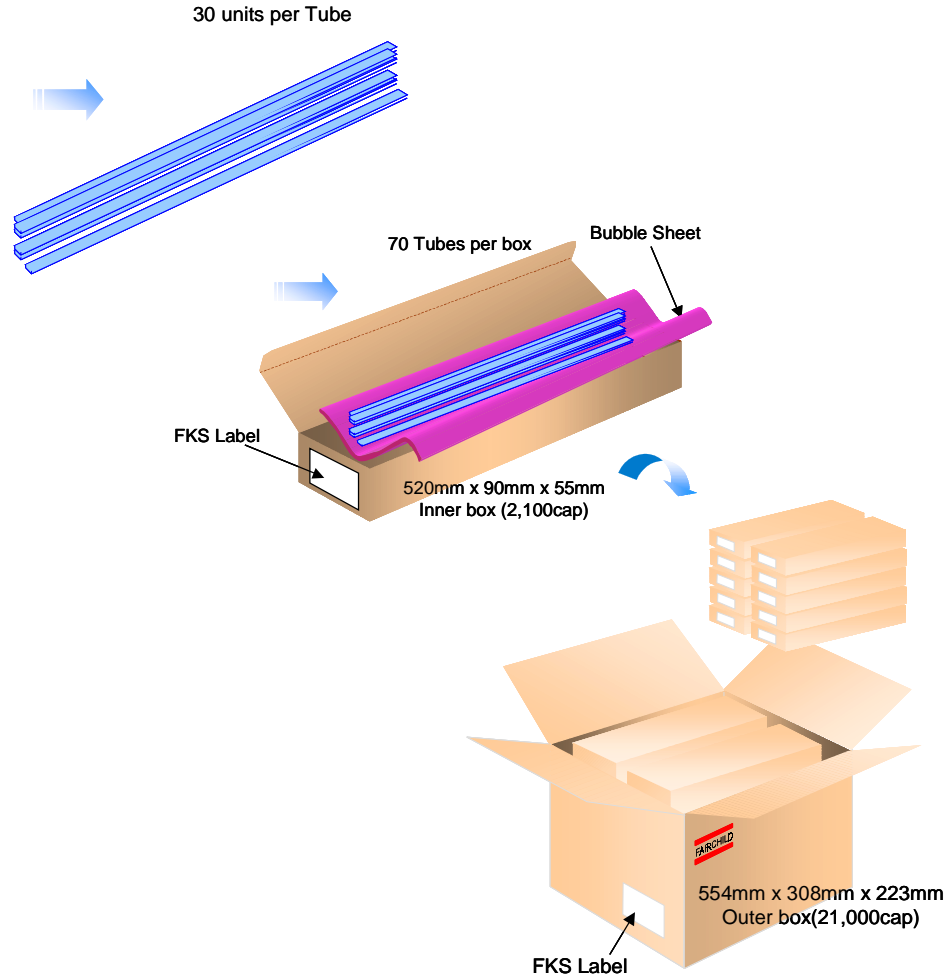

22-SOP-300 Tube Configuration: Figure 6.0

Note: All dimensions are in mm

