

28-SSOPH-375-SG2 Tape and Reel Data

28-SSOPH-375-SG2 Packaging
Configuration: Figure 1.0



Packaging Description:

28-SSOPH-375-SG2 parts are shipped normally in tape. The carrier tape is made from a dissipative (carbon filled) polycarbonate resin. The cover tape is a multilayer film (Heat Activated Adhesive in nature) primarily composed of polyester film, adhesive layer, sealant, and anti-static sprayed agent. These reeled parts in standard option are shipped with 1,000 units per 13" or 330cm diameter reel. The reels are dark blue or black in color and is made of polystyrene plastic (anti-static coated). This and some other options are further described in the Packaging Information table. These full reels are individually barcode labeled and placed inside a standard intermediate box (illustrated in figure 1.0) made of recyclable corrugated brown paper. One box contains two reels maximum. And these boxes are placed inside a barcode labeled shipping box which comes in different sizes depending on the number of parts shipped.

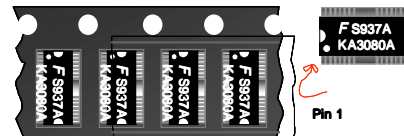
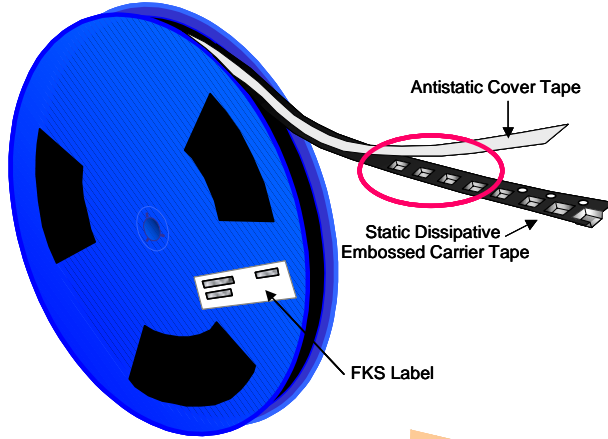

28-SSOPH-375-SG2 Unit Orientation

28-SSOPH-375-SG2 Packaging Information		
Packaging Option	Standard (no flow code)	-
Packaging type	TNR	Rail/Tube
Qty per Reel/Tube/Bag	1,000	25
Reel Size	13" Dia	-
Inner Box Dimension (mm)	339x352x68	520x90x55
Max qty per Box	2,000	1,500
Outer Box Dimension (mm)	385x363x363	554x308x223
Max qty per Box	10,000	15,000
Weight per unit (gm)	0.8135	0.8135
Weight per Reel (kg)	-	-
Note/Comments		

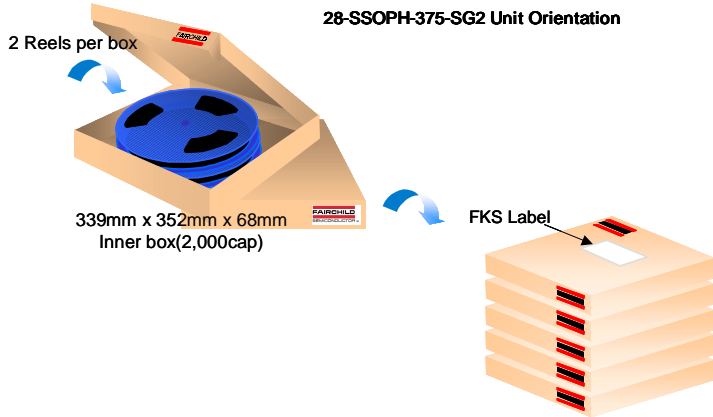

Inner Box Barcode Label Sample

MBB: NOR P/U: 660 P 00/03/17
 S/T: LOGO IB: LOGO 08:30
 H/C: 0 P/T: 0 M/D: X ETC:

DVC: KA7812-AE

LOT: TKLEE777 QTY: 1000 WW: 0103 01
 OPTION: 20000025

Outer Box Barcode Label Sample

00/03/17 07:30

DVC: KA7812-AE
 LOT: MSYS777 IM 01
 QTY: 12000

A710103105 86706892 7103

28-SSOPH-375-SG2 Tape Leader and Trailer Configuration: Figure 2.0

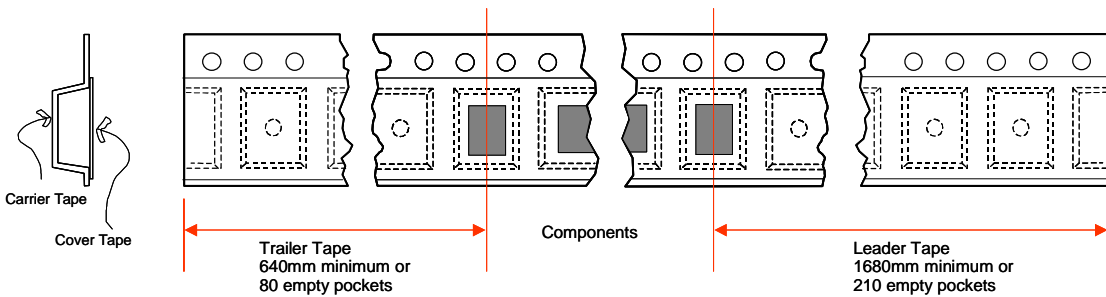

28-SSOPH-375-SG2 Tape and Reel Data, continued

28-SSOPH-375-SG2 Embossed Carrier Tape Configuration:
Figure 3.0

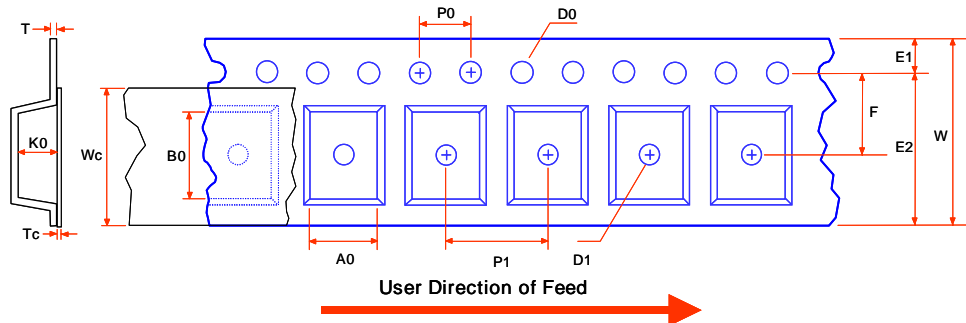

Dimensions are in millimeter

Pkg type	A0	B0	W	D0	D1	E1	E2	F	P1	P0	K0	T	Wc	Tc
28-SSOPH-375 (24mm)	10.50 ±0.10	18.90 ±0.10	24.0 ±0.3	1.5 +0.10 -0.00	1.50 min	1.75 ±0.10	22.25 min	11.50 ±0.10	16.0 ±0.1	4.0 ±0.1	3.10 ±0.10	0.30 ±0.05	21.3 ±0.1	0.10 max

Notes: A0, B0, and K0 dimensions are determined with respect to the EIA/Jedec RS-481 rotational and lateral movement requirements (see sketches A, B, and C).

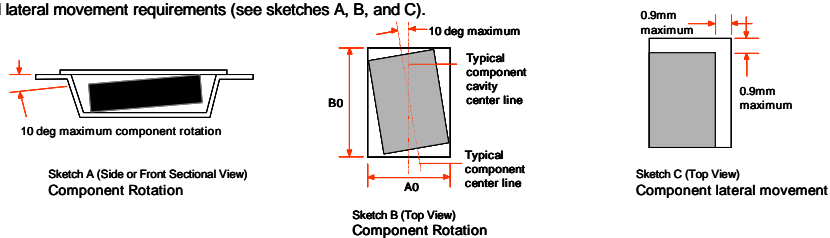

28-SSOPH-375-SG2 Reel
Configuration: Figure 4.0

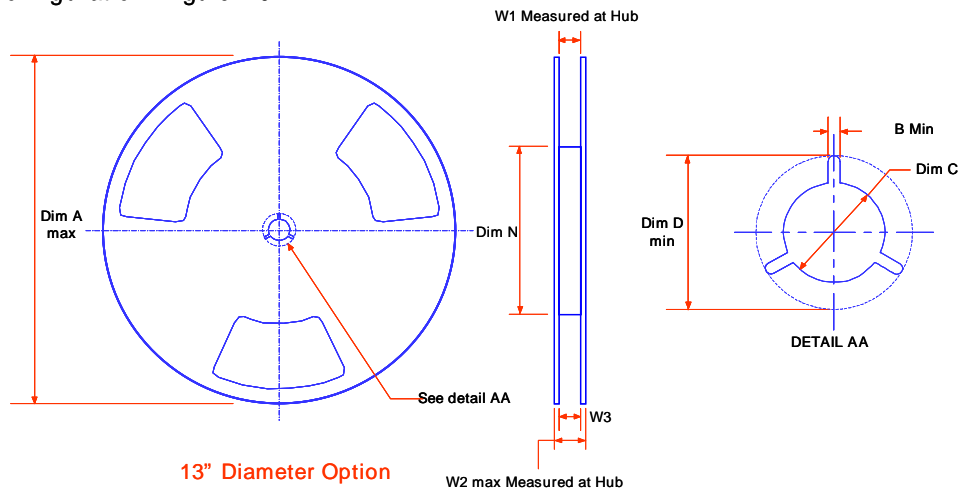

Dimensions are in inches and millimeters

Tape Size	Reel Option	Dim A	Dim B	Dim C	Dim D	Dim N	Dim W1	Dim W2	Dim W3 (LSL-USL)
24.0mm	13" Dia	13.00 330	0.059 1.5	0.512 +0.020/-0.008 13 +0.5/-0.2	0.795 20.2	4.00 100	0.960 +0.078/-0.000 24.4 +20	1.196 30.4	0.940 -1.078 23.9 - 27.4

28-SSOPH-375-SG2 Tape and Reel Data

28-SSOPH-375-SG2 Tube Packing
Configuration: Figure 5.0

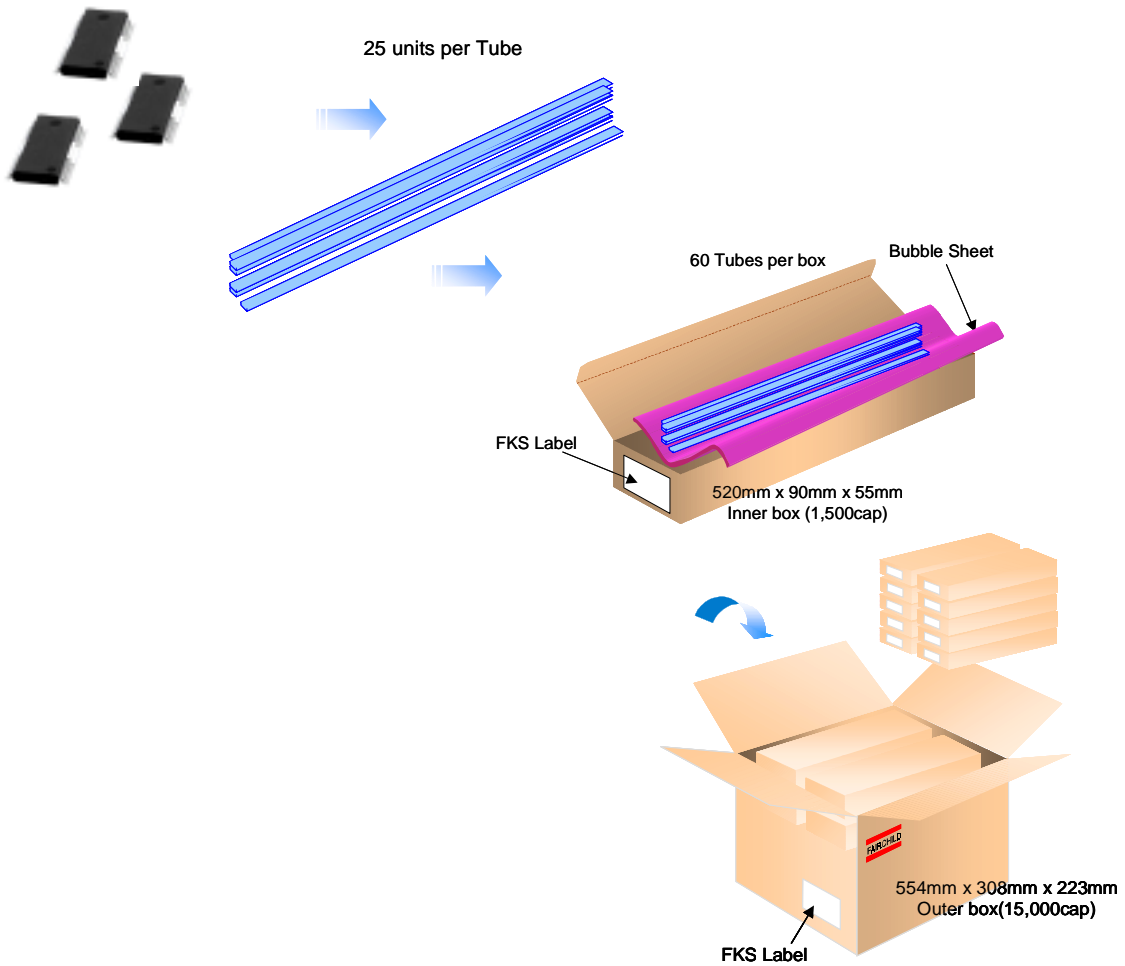

28-SSOPH-375-SG2 Tube Configuration: Figure 6.0

Note: All dimensions are in mm

