

SOD-123 Tape and Reel Data

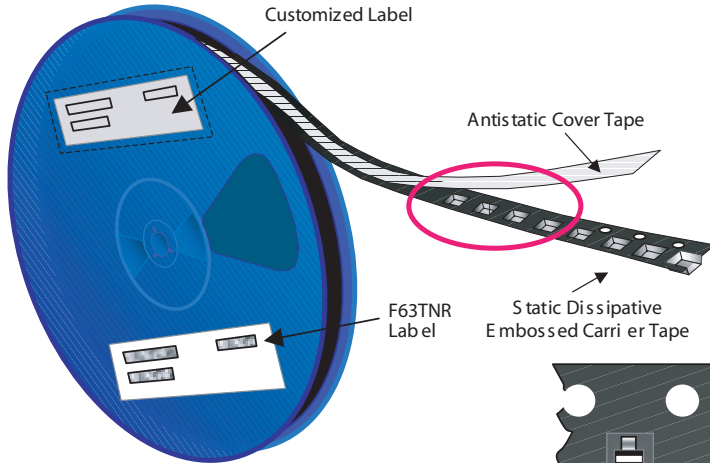

SOD-123 Packaging Configuration: Figure 1.0



Packaging Description:

SOD-123 parts are shipped in tape. The carrier tape is made from a dissipative (carbon filled) polycarbonate resin. The cover tape is a multilayer film (Heat Activated Adhesive in nature) primarily composed of polyester film, adhesive layer, sealant, and anti-static sprayed agent. These reeled parts in standard option are shipped with 3,000 units per 7" or 177mm diameter reel. The reels are dark blue in color and is made of polystyrene plastic (anti-static coated). Other option comes in 10,000 units per 13" or 330cm diameter reel. This and some other options are described in the Packaging Information table.

These full reels are individually barcode labeled and placed inside a pizza box (illustrated in figure 1.0) made of recyclable corrugated brown paper with a Fairchild logo printing. One pizza box contains five reels maximum. And these pizza boxes are placed inside a barcode labeled shipping box which comes in different sizes depending on the number of parts shipped.

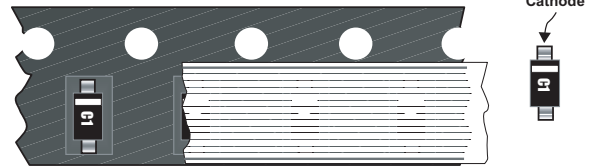

SOD-123

SOD-123 Packaging Information		
Packaging Option	Standard (no flow code)	D87Z
Packaging type	TNR	TNR
Qty per Reel/Tube/Bag	3,000	10,000
Reel Size	7" Dia	13"
Box Dimension (mm)	193x183x80	355x333x40
Max qty per Box	15,000	30,000
Weight per unit (gm)	0.01	0.01
Weight per Reel (kg)	0.123	0.420
Note/Comments		

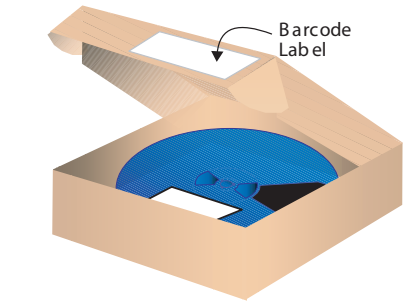
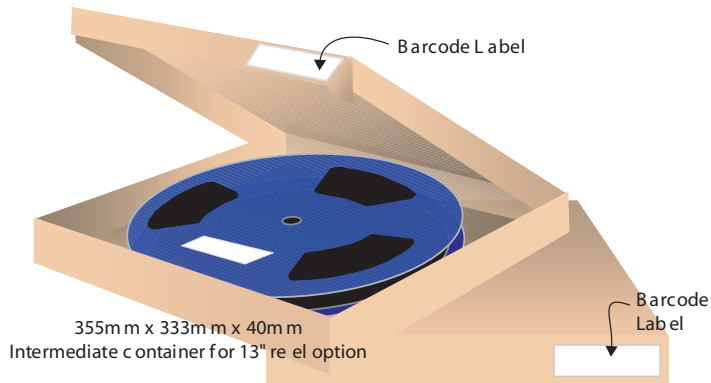

193mm x 183mm x 80mm
Pizza Box for Standard Option

Barcode Label sample



SOD-123 Tape Leader and Trailer Configuration: Figure 2.0

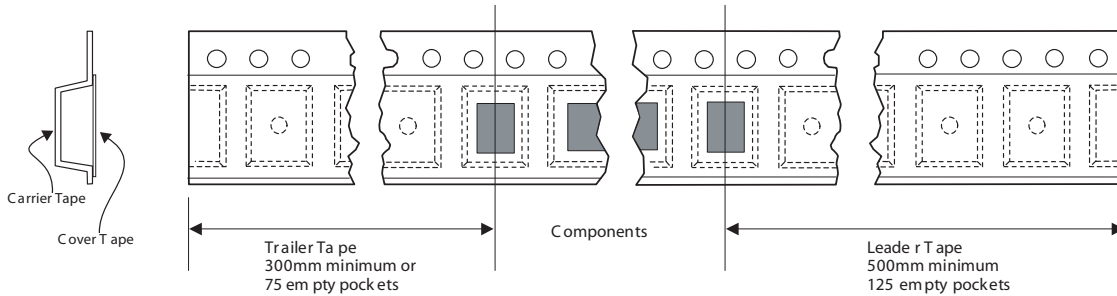

SOD-123 Tape and Reel Data, continued

SOD-123 Embossed Carrier Tape Configuration: Figure 3.0

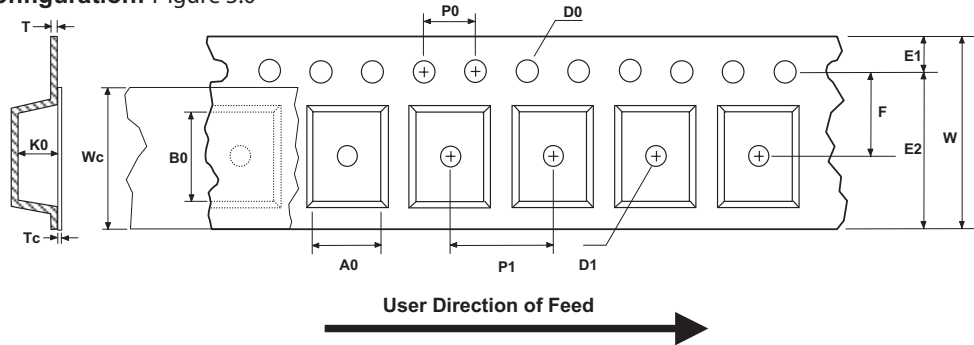

Dimensions are in millimeter														
Pkg type	A0	B0	W	D0	D1	E1	E2	F	P1	P0	K0	T	Wc	Tc
SOD-123 (8mm)	1.85 +/-0.10	3.94 +/-0.10	8.0 +/-0.3	1.50 +/-0.10	1.125 +/-0.125	1.75 +/-0.10	6.25 min	3.50 +/-0.05	4.0 +/-0.1	4.0 +/-0.1	1.50 +/-0.10	0.200 +/-0.020	5.2 +/-0.2	0.06 +/-0.02

Notes: A0, B0, and K0 dimensions are determined with respect to the EIA/Jedec RS-481 rotational and lateral movement requirements (see sketches A, B, and C).

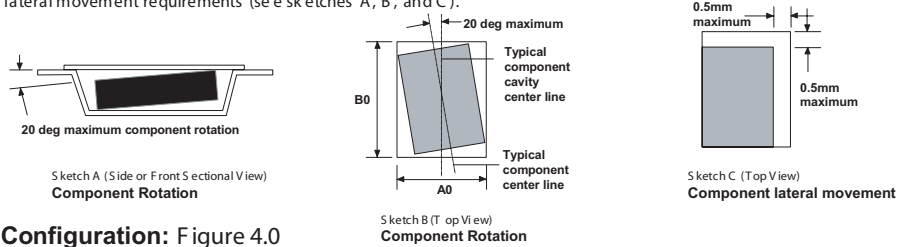

SOD-123 Reel Configuration: Figure 4.0

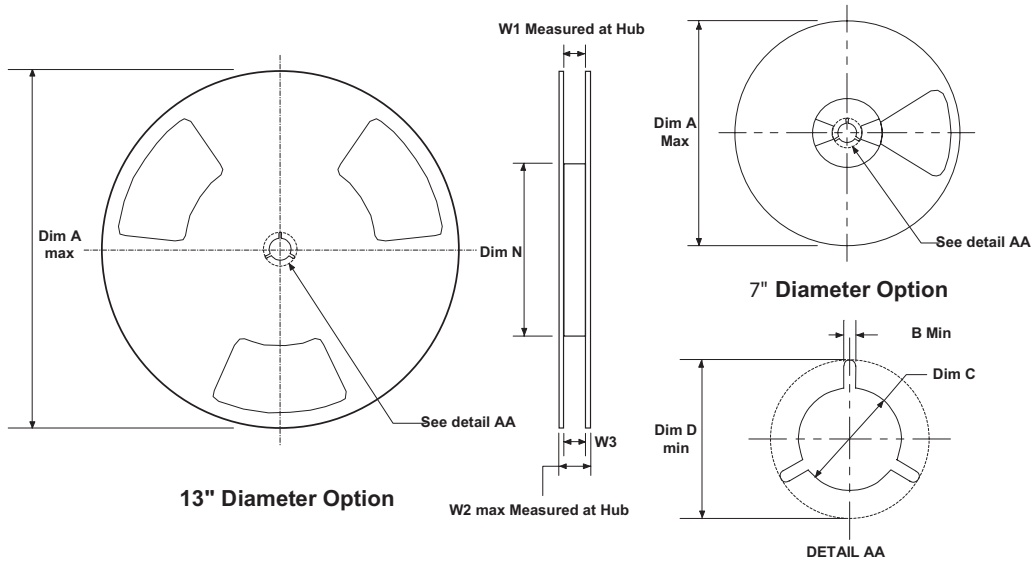

Dimensions are in inches and millimeters									
Tape Size	Reel Option	Dim A	Dim B	Dim C	Dim D	Dim N	Dim W1	Dim W2	Dim W3 (LSL-USL)
8mm	7" Dia	7.00 177.8	0.059 1.5	512 + 0.020/-0.008 13 + 0.5/-0.2	0.795 20.2	2.165 55	0.331 + 0.059/-0.000 8.4 + 1.5/0	0.567 14.4	0.311 \varnothing 0.429 7.9 \varnothing 10.9
8mm	13" Dia	13.00 330	0.059 1.5	512 + 0.020/-0.008 13 + 0.5/-0.2	0.795 20.2	4.00 100	0.331 + 0.059/-0.000 8.4 + 1.5/0	0.567 14.4	0.311 \varnothing 0.429 7.9 \varnothing 10.9