

SOIC-4 Tape and Reel Data

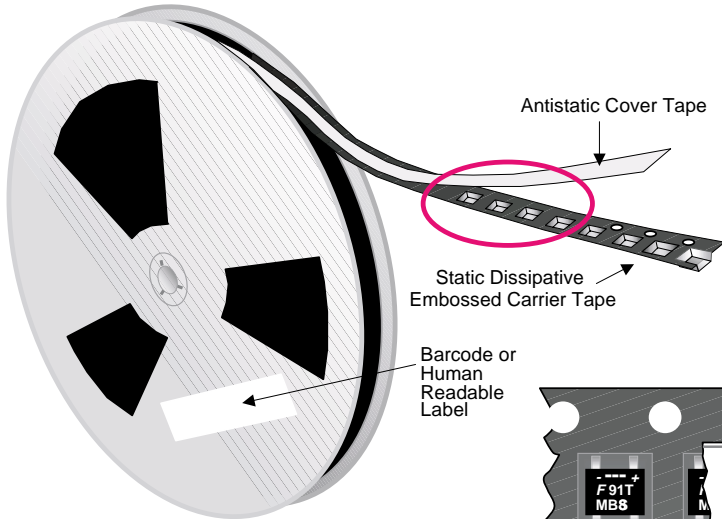

SOIC-4 Packaging Configuration: Figure 1.0



Packaging Description:

SOIC-4 parts are shipped in tape. The carrier tape is made from a dissipative (carbon filled) polycarbonate resin. The cover tape is a multilayer film (Heat Activated Adhesive in nature) primarily composed of polyester film, adhesive layer, sealant, and anti-static sprayed agent. These reeled parts in standard option are shipped with 2500 units per 13" or 330cm diameter reel. The reel comes in plastic or carton which is made of polystyrene plastic (anti-static coated or carbon treated) and thick white paper respectively. Further information is described in the Packaging Information table.

These full reels are individually labeled and placed inside a bleach box (illustrated in figure 1.0) made of recyclable carton paper with a Fairchild logo printing. One box contains two reels maximum. Certain number of these boxes are placed inside shipping box which comes in different sizes depending on the number of parts shipped.

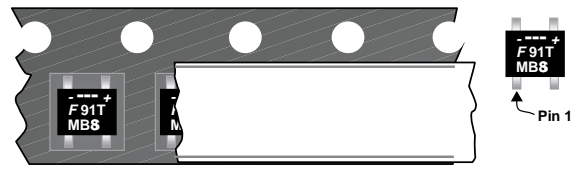

SOIC-4 Unit Orientation

SDIP Packaging Information	
Packaging Option	Under package code N3
Packaging type	TNR
Qty per Reel/Tube/Bag	2,500
Reel Size	13" Dia
Box Dimension (mm)	336x336x38
Max qty per Box	5,000
Weight per unit (gm)	0.220
Weight per Reel (kg)	0.700
Note/Comments	

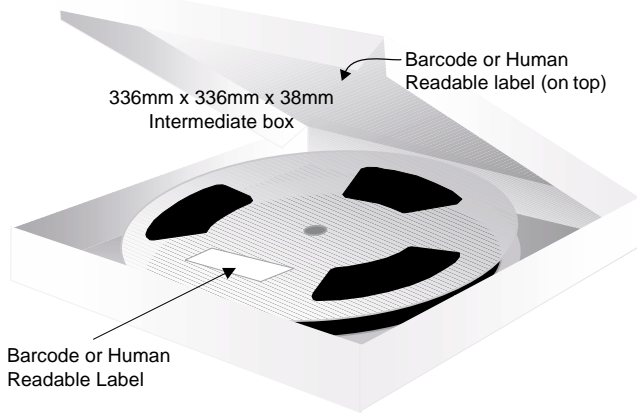

Human Readable Label sample



Barcode or Human Readable Label

Barcode Label sample

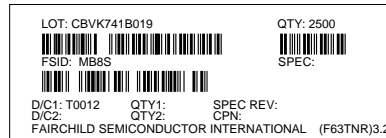

SOIC-4 Tape Leader and Trailer Configuration: Figure 2.0

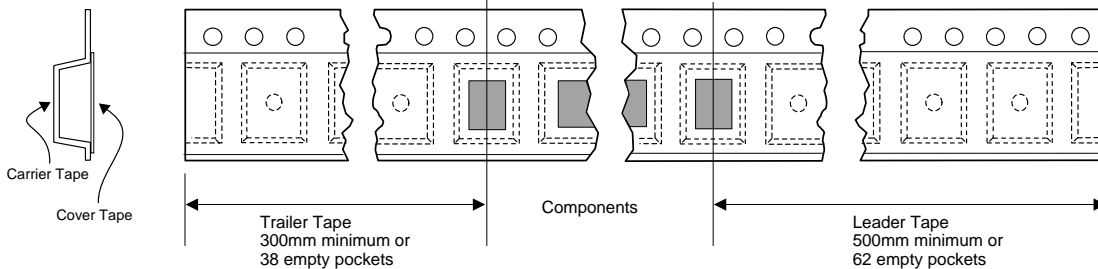

SOIC-4 Tape and Reel Data, continued

SOIC-4 Embossed Carrier Tape Configuration: Figure 3.0

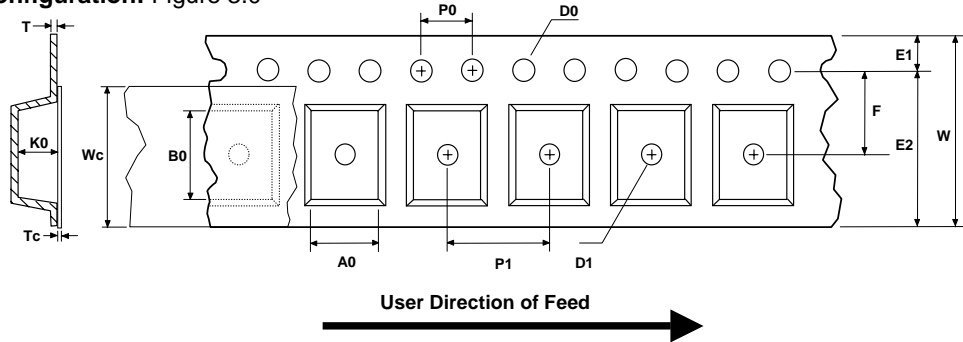

Dimensions are in millimeter														
Pkg type	A0	B0	W	D0	D 1	E1	E2	F	P1	P0	K0	T	Wc	Tc
SOIC-4 (12mm)	4.9 +/-0.10	7.24 +/-0.10	12.0 +/-0.3	1.55 +/-0.05	1.50 +/-0.10	1.75 +/-0.10	14.25 min	5.50 +/-0.10	8.0 +/-0.1	4.0 +/-0.1	3.33 +/-0.10	0.32 min	9.20 +/-0.3	0.10 max

Notes: A0, B0, and K0 dimensions are determined with respect to the EIA/Jedec RS-481 rotational and lateral movement requirements (see sketches A, B, and C).

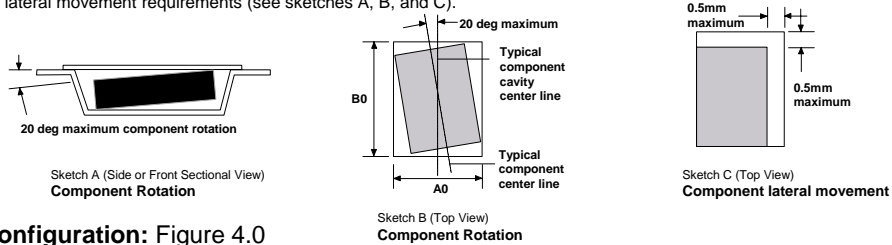

SOIC-4 Reel Configuration: Figure 4.0

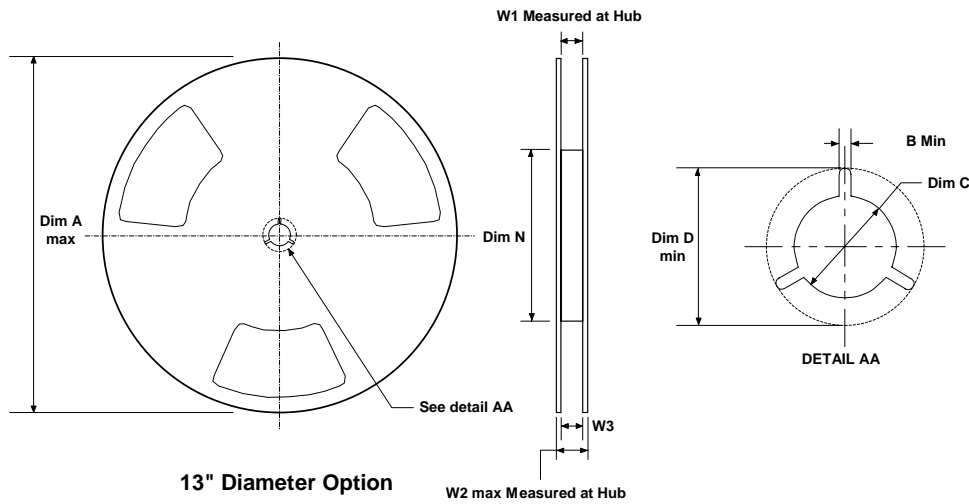

Dimensions are in inches and millimeters									
Tape Size	Reel Option	Dim A	Dim B	Dim C	Dim D	Dim N	Dim W1	Dim W2	Dim W3 (LSL-USL)
12mm	13" Dia	13.00 330	0.059 1.5	512 +0.020/-0.008 13 +0.5/-0.2	0.795 20.2	1.97 min 50 min	0.488 +0.078/-0.000 12.4 +2/0	0.724 18.4	0.469 - 0.606 11.9 - 15.4