

# Stretch-247

## 3 LEAD JEDEC STYLE TO-247 PLASTIC PACKAGE

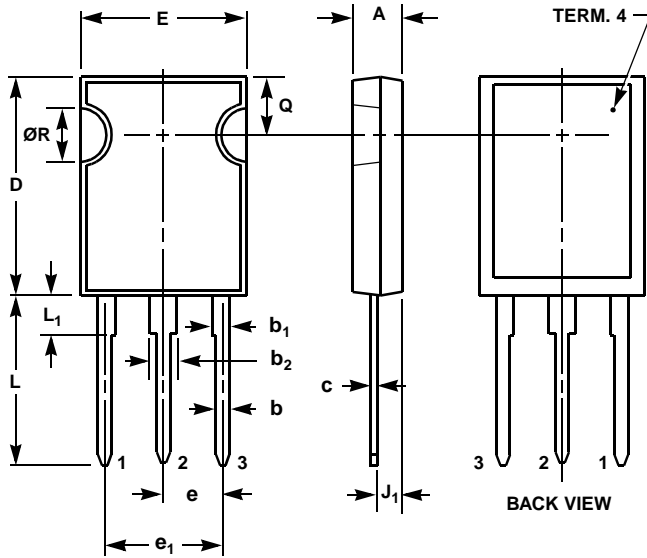

SYMBOL	INCHES		MILLIMETERS		NOTES
	MIN	MAX	MIN	MAX	
A	0.18	0.190	4.58	4.82	-
b	0.04	0.051	1.17	1.29	2, 3
b <sub>1</sub>	0.06	0.070	1.53	1.77	1, 2
b <sub>2</sub>	0.09	0.105	2.42	2.66	1, 2
c	0.02	0.026	0.51	0.66	1, 2, 3
D	0.80	0.820	20.3	20.8	-
E	0.60	0.625	15.3	15.8	-
e	0.219 TYP		5.56 TYP		4
e <sub>1</sub>	0.438 BSC		11.12 BSC		4
J <sub>1</sub>	0.09	0.105	2.29	2.66	5
L	0.62	0.640	15.7	16.2	-
L <sub>1</sub>	0.14	0.155	3.69	3.93	1
Q	0.21	0.220	5.34	5.58	-
ØR	0.19	0.205	4.96	5.20	-

**NOTES:**

1. Lead dimension and finish uncontrolled in L<sub>1</sub>.
2. Lead dimension (without solder).
3. Add typically 0.002 inches (0.05mm) for solder plating.
4. Position of lead to be measured 0.250 inches (6.35mm) from bottom of dimension D.
5. Position of lead to be measured 0.100 inches (2.54mm) from bottom of dimension D.
6. Controlling dimension: Inch.
7. Revision 1 dated 8-99.