

Tape and Reel Specifications for Through Hole Packages

Ordering Information

To order Infrared (IR) Products on tape and reel include the appropriate standard product part number and suffix code to specify configuration and optional features.

QSDXXXA6R0



Category Code

The category code for Infrared (IR) products is always "0".

Package Code

Code	Packages	Quantity
A	T-1 3/4, TO-18, TO-46	1,200
C	T-1	2,000
E	Sidelooker	2,000

Height Code

Code	Height (mm)
1	16.5 ⁽⁵⁾
2	17.5 ⁽⁵⁾
3	18.5 ⁽⁵⁾
4	20.5 ⁽⁵⁾
5	22.5 ⁽⁵⁾
6	24.5 ⁽⁵⁾

Tolerance is ±1mm.

Notes:

1. Automatic PCB assembly for most T-1 and T-1 3/4 leads with radial insertion machines.
2. Meets ANSI/EIA standard RS-468.
3. The maximum number of consecutive missing lamps is three.
4. Standard 0.10" (2.54mm) spacing.
5. Height (H) is measured from center of tape to base of flange. See H dimension in the tape dimensions section.



Tape and Reel Specifications for Through Hole Packages

Tape and Reel Specifications for Through Hole Packages

Tape Dimensions

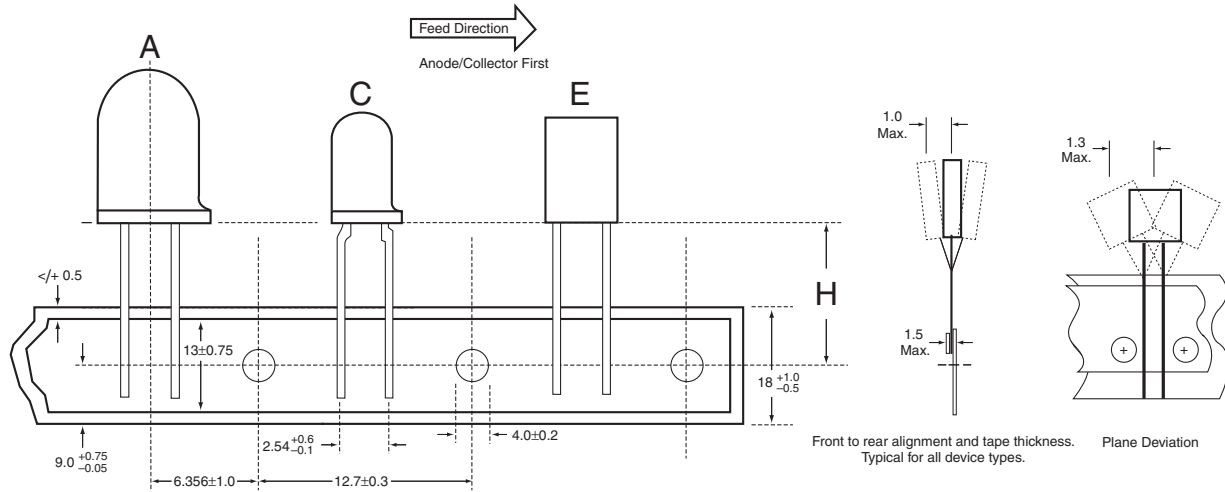

Reel Dimensions

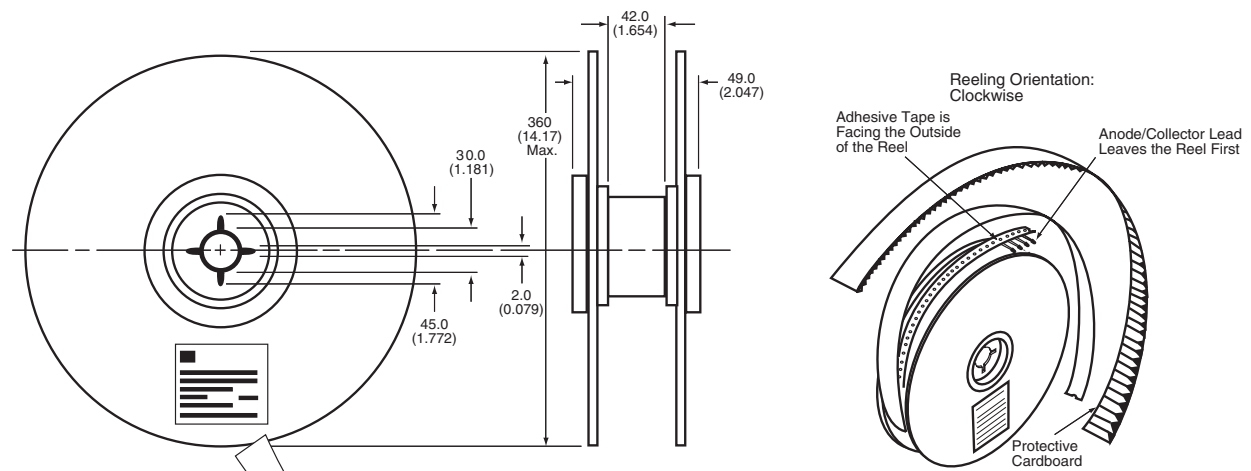

PRODUCT	_____
PART NUMBER	_____
DATE CODE	_____
TAPING DATE	_____
ELEC. VALUE	_____
TOLERANCE	_____
QUANTITY	_____
CUSTOMER PART NUMBER	_____