

Abstract

Video filters are evolving according to classic Darwinian principals by adapting to market trends such as the emergence of enhanced and high definition video, 1080p, various and shifting output channel counts, mobile video, 3V supplies, and green requirements, to name just a few. As video filter products evolve, so do their input and output coupling and clamping methodologies. We will look at the some of the trade-offs of the different implementations of input and output coupling and input clamping methods that apply to video filters and identify their relative advantages and disadvantages.

Coupling, Clamping, and Video Filters

Video filters are evolving according to classic Darwinian principals by adapting to market trends such as the emergence of enhanced and high definition video, even higher definition (1080p), various and shifting output channel counts, mobile video, 3V supplies, and green requirements, to name just a few. Video filters started as complicated and expensive discrete solutions that adhered to rigorous broadcast standards. Over time they morphed into cost effective, tiny integrated circuits with increasing ease of design for a variety of consumer platforms. Part of the evolutionary process included the adaptation of input and output interfacing methods to create simpler and more cost effective systems. The integrated circuit video filter products that lead the market today, such as Fairchild's wide range of video filter driver offerings have set new performance and cost standards. As video filter products evolved, so have their input and output coupling and clamping methodologies. We will look at the some of the trade-offs of the different implementations of input and output coupling and input clamping methods that apply to video filters and identify their relative advantages and disadvantages.

Video filter drivers are necessary components to produce high quality video equipment such as DVD, Blu Ray, set top box, and television systems. Even mobile equipment such as PMPs and cell phones need video filter drivers now to ensure the integrity of their video outputs as video goes mobile. To use a video filter driver a designer should be cognizant of the key interfacing methods and details such as clamp and bias, DC-restore, AC and DC-coupling of inputs and outputs, and other items. Video filter drivers typically employ either sync strip with pulse DC-restore or continuous time clamp/bias techniques. The latter is more popular at present due to inherent cost savings.

AC-coupled Video Input:

Figure 1 shows an AC-coupled video input configuration using a capacitor prior to the filter. This architecture allows the receiving device (the filter) to set the optimum DC-bias level regardless of the DC-bias level of the driving signal. This

is useful if the receiving device wants to set the clamping or video blanking level equal to the internal ADC code-zero voltage, regardless of the driving signal's absolute DC level. Another case is an analog system in which the receiving filter device wants to set the analog signal's common mode level around $V_{CC}/2$ to optimize processing headroom. The receiving filter device can match the clamped-level to a predetermined DC reference voltage to provide a consistent and stable DC output voltage. DC blocking, of course, is the classic method for protection from damaging DC current flows.

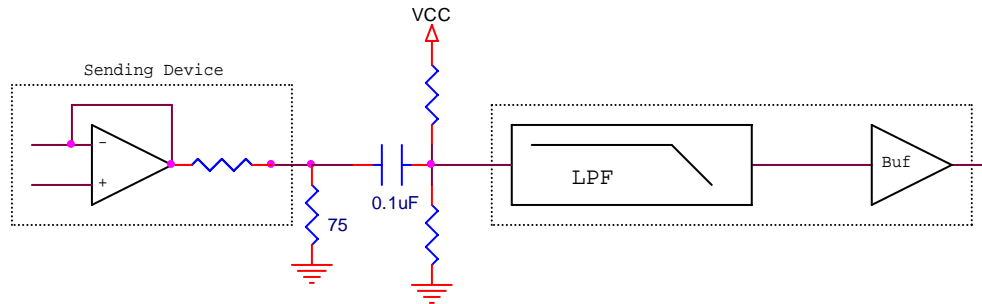

Figure (1) AC-Coupled Input

Sync Strip and Pulsed DC-Restore clamping:

The clamping method of Figure 2 illustrates DC-restore of an AC-coupled video input signal by slicing through the embedded sync section of the signal to create a digital pulse, which is used to trigger a charge pump circuit. At the point of sync detection, the charge pump is enabled forcing the input capacitor to be charged or discharged in proportion to an on-chip error voltage. This is in the context of a closed-loop feedback system. The system converges on the bias voltage over the first several lines to correct for any small errors on each successive line.

The advantages of DC-restore clamping:

- 1) DC-restore has the ability to be triggered by the horizontal sync (HSYNCH) event, which allows updates and corrections in the bias level for every line, even during a non-active portion of the video. Since the DC reference level can be generated from an on-chip band gap voltage, the system can lock to a known DC level allowing the DC output levels of the device to be accurately controlled and remain flat over temperature and voltage variations.
- 2) DC-restore is very compatible with DC output coupling.

The disadvantages of DC-Restore clamping:

- 1) The need of an input capacitor (although this capacitor can be relatively small in value, typically 0.1uF).

- 2) Cost increase associated with larger die size to put this function onto silicon.
- 3) The internal sync stripper must be designed with a range of pre-determined formats for accurate processing of the sync signal to generate the internal clamp pulse. Input formats outside of the pre-determined range may not achieve proper DC-restore performance without application of an external sync pulse.
- 4) The source's input impedance can impair the function of the DC-restore circuit.

Most input video signals originate from relatively low drive impedance sources, with 75 ohms being standard (doubly terminated 75 ohms equals 37.5 ohms). Some applications may require higher drive impedances, such as a 300 ohm loaded DAC. In this case the drive impedance can have an adverse impact on the DC restore performance.

Fairchild's popular FMS6403 selectable definition video filter driver and FMS6406 S-video filter with summed composite output support DC-restore clamping methodology, triggered from the channel with embedded sync (Y, G, or CV) with the chrominance channels (Pb, Pr, or C) being pumped to the appropriate DC levels during the triggered event. The FMS6403 allows for an external digital separated sync input triggering the clamping event. With a digital separated sync, the device can be put into external sync mode and the digital HSYNC can then be used as the sync input to trigger the clamping. This allows for a proper DC-restore of graphics formats that may not have been compatible with the internal sync stripper and clamp generator. The DC-restore approach can also be implemented with back-porch clamping (as with the FMS6403 programmed to HD mode), which keeps a constant blanking level even with large variations in the absolute sync amplitude. The FMS6403 and FMS6406 can tolerate impedances up to 150 ohms. Higher drive impedances are prone to stability problems using this approach.

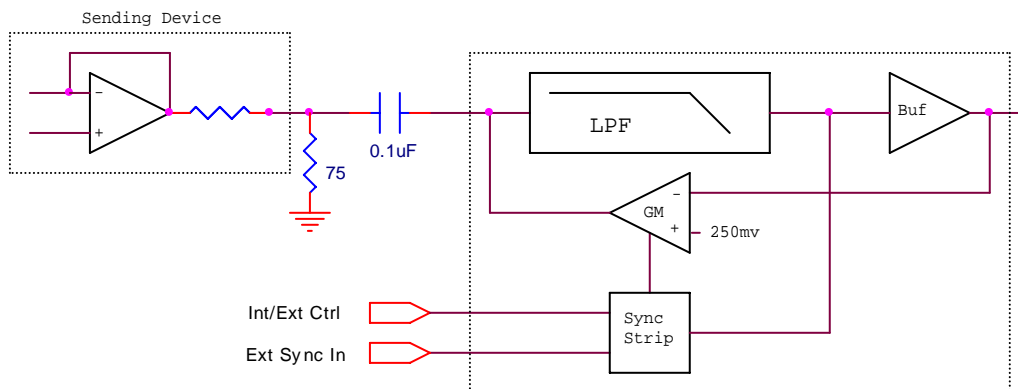

Figure (2) Sync Stripper with DC Restore

Clamp/Bias Input Circuitry: (Figure 3)

Most of the more modern video filter drivers on the market, such as Fairchild's FMS6143A (3-channel SD), FMS6144A (4-channel SD), FMS6363 (3-channel HD), FMS6364A (3-channel HD+1 channel SD), FMS6346 (3-channel HD+ 3-channel SD), and FMS6303 (3-channel switchable SD/ED/HD/1080p) as well as several other family members, offer clamp/bias circuitry on the input of the chip to set the DC bias for AC-coupled applications.

The default setting is clamp mode. Alternatively, a 7.5M ohm resistor to VCC sets up bias mode. In clamp mode the circuit clamps the lowest level (usually the bottom of the sync tip) of the incoming video signal to a predetermined on-chip reference voltage level. The clamp circuit is not triggered by a sync tip event, but rather by a continuous time circuit that clamps the lowest level of the input to a predetermined DC level while preventing the signal from falling below this level. In bias mode, the input is biased to the mid-scale reference voltage level through an on-chip high impedance source. This style of clamping is different from the pulsed DC-restore circuit since there is no internal sync stripper and pulsed charge pump circuit and no closed loop system monitoring of the output level.

The advantages of the clamp/bias approach:

- 1) Reduction of on-chip circuitry which means less die area and lower cost.
- 2) Independence from predetermined timing and formats (since no sync stripper and pulse generator are necessary), which allows more compatibility with unsupported video and/or graphics formats.
- 3) Ability to be driven with a DC-coupled input in certain applications such as a known DC input drive.

The disadvantages of the clamp bias approach:

- 1) Output DC voltages may vary with system temperature and supply voltage variations.
- 2) There is not a closed loop system controlling the absolute output level and the device output level is dependent on the amplitude of the sync. If the sync amplitude varies with respect to the active video amplitude, the DC level of the output will momentarily shift as the clamp adjusts.

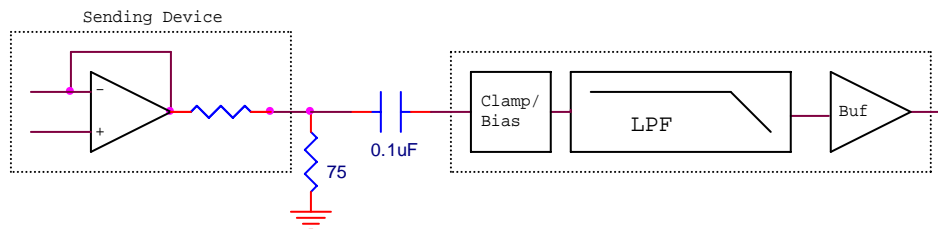

Figure (3) AC Coupled Input with Clamp/Bias

DC Coupled Input: (Figure 4)

The FMS6141, FMS6151, and FMS6410B are examples of video filters with use DC-coupled input capabilities. DC-coupling the input of a video filter is useful in applications using a DAC with a standard current-mode, single ended ground referenced output.

The advantages of DC-coupling inputs:

- 1) no need for a input coupling cap,
- 2) no settling time for the clamp,
- 3) no tilt from the input cap discharge,
- 4) no glitch pulse,
- 5) no input impedance limitation (as with pulsed DC restore loop), and
- 6) no need for the on-chip sync-stripper, charge pump circuitry, and servo loop.

The disadvantages of DC-coupling inputs:

- 1) The input signal must be at a known DC level and biased with a voltage swing in the range of 0 to 1.3v DC.
- 2) There is no feedback control on the absolute DC level of the output voltage and thus the level may vary with system temperature and supply voltage.

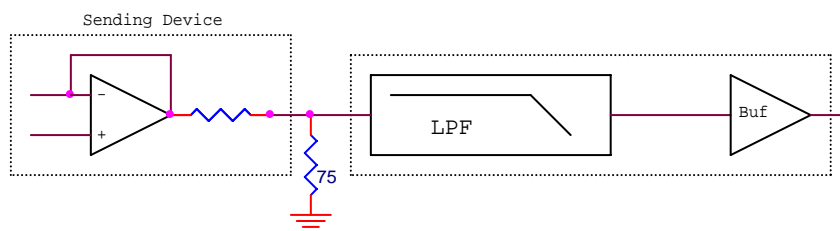

Figure (4) DC-Coupled Input

AC-Coupled Output: (Figure 5)

The most common approach used to interface a video filter to the system's output connector is AC-coupling, which sets the common mode level on the filter's input, independent of the incoming video signal DC level. A 75 ohm series resistor should be placed as close to the device output as possible to isolate down-stream parasitics. The AC-coupling capacitor should be a minimum of 200 uF, which is the smallest coupling capacitor value that can achieve acceptable field tilt. Applications with more stringent field tilt requirement typically use 470uF or 1000uF coupling capacitors.

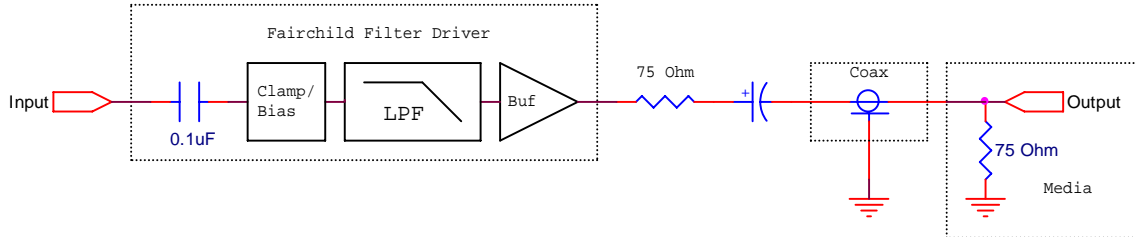

Figure (5) AC Coupled Output

DC-Coupled Output: (Figure 6)

The most straight forward approach used to interface to a visual media device is to DC-couple the signal.

The advantages of DC-coupled outputs:

- 1) No need for a coupling capacitor
- 2) Allows for a tilt free signal to be sent to the media device.

The disadvantage of DC-coupled outputs:

The receiving device will need to know the incoming DC levels so it can process the video signal properly. This will work for a system designed to handle known DC levels but may cause a problem with systems which expect the common mode level at a different reference point.

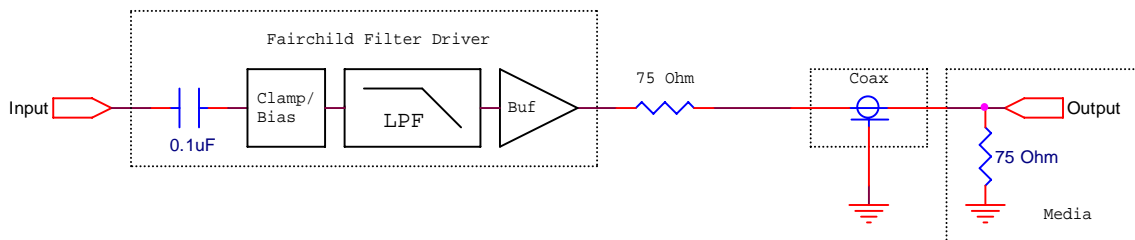

Figure (6) DC-Coupled Output

Summary:

Video filter/driver products possess a variety of possible input/output signal coupling and clamping configurations. System designers have the choice of input/output AC or DC coupling. The choices for clamping options include the classic sync strip and pulsed DC restore circuit, the continuous time clamped/bias circuit, or DC coupling. Each type of implementation has specific advantages and limitations for a given application, which needs to be taken into consideration by the system designer.

Earl Schreyer is a Member Technical Staff, with 19 years of experience in designing integrated circuits with an EE degree from Arizona State University. He began his career with Fairchild Semiconductor in 1999 in the analog and mixed signal group, building on the analog and high-speed ADC work in the application of video/graphics digitizers and continuous-time video filter drivers. He also builds and markets hand-wired vacuum-tube guitar amps (Schreyer Audio).

Duane Sorlie is a Senior Staff Engineer for the signal-conditioning product line, with thirty-three years of experience in the semiconductor field. He has written several articles and applications notes related to the system level implementation of "Video/Filter Drivers".

Bill Boldt is a Senior Business Development Manager for analog signal-path products with an EE degree from Notre Dame and Masters of Management (MBA) from Kellogg (Northwestern). His focus is on strategic and tactical market development of analog integrated circuits for mobile applications. Previously Bill held general management and marketing positions with TDK Semiconductor, CP Clare (IXYS) and Silicon Systems, Inc., and also ran a privately owned industrial design firm.