



Is Now Part of



ON Semiconductor®

To learn more about ON Semiconductor, please visit our website at
www.onsemi.com

ON Semiconductor and the ON Semiconductor logo are trademarks of Semiconductor Components Industries, LLC dba ON Semiconductor or its subsidiaries in the United States and/or other countries. ON Semiconductor owns the rights to a number of patents, trademarks, copyrights, trade secrets, and other intellectual property. A listing of ON Semiconductor's product/patent coverage may be accessed at www.onsemi.com/site/pdf/Patent-Marking.pdf. ON Semiconductor reserves the right to make changes without further notice to any products herein. ON Semiconductor makes no warranty, representation or guarantee regarding the suitability of its products for any particular purpose, nor does ON Semiconductor assume any liability arising out of the application or use of any product or circuit, and specifically disclaims any and all liability, including without limitation special, consequential or incidental damages. Buyer is responsible for its products and applications using ON Semiconductor products, including compliance with all laws, regulations and safety requirements or standards, regardless of any support or applications information provided by ON Semiconductor. "Typical" parameters which may be provided in ON Semiconductor data sheets and/or specifications can and do vary in different applications and actual performance may vary over time. All operating parameters, including "Typicals" must be validated for each customer application by customer's technical experts. ON Semiconductor does not convey any license under its patent rights nor the rights of others. ON Semiconductor products are not designed, intended, or authorized for use as a critical component in life support systems or any FDA Class 3 medical devices or medical devices with a same or similar classification in a foreign jurisdiction or any devices intended for implantation in the human body. Should Buyer purchase or use ON Semiconductor products for any such unintended or unauthorized application, Buyer shall indemnify and hold ON Semiconductor and its officers, employees, subsidiaries, affiliates, and distributors harmless against all claims, costs, damages, and expenses, and reasonable attorney fees arising out of, directly or indirectly, any claim of personal injury or death associated with such unintended or unauthorized use, even if such claim alleges that ON Semiconductor was negligent regarding the design or manufacture of the part. ON Semiconductor is an Equal Opportunity/Affirmative Action Employer. This literature is subject to all applicable copyright laws and is not for resale in any manner.

AN-5086

USB Type C, CC Pin Design Considerations

High voltage design considerations for Type-C connector pins in systems supporting non-USB standard charging protocol and/or fault cases.

Summary

When designing hardware systems with type C connectors, a designer also has to consider all legacy, standard, and non-standard specifications that exist in the USB connector eco system. With the introduction of the Type C connector and the Configuration channel (CC Pin) new challenges occur trying to ensure overall system robustness. This note addresses some of the concerns with the CC pin in a robust system environment.

Design Considerations – System ESD and Surge

IEC61000-4-2 (henceforth called just “IEC”) is the industry’s standard for system level ESD testing. IEC testing is a system level test, while other ESD specifications like Charged Device Model (CDM) and Human Body Model (HBM) target the manufacturing process and human handling. Most IC’s have integrated Electro-Static Discharge (ESD) protection intended to protect the device during manufacturing while external protection in the form of a TVS is added for the IEC system level testing. It is very important to understand that, implementing TVS protection

at the system level and having it work together with the individual IC, is the best way to achieve overall system robustness.

Below are few important specifications to ensure the right TVS is selected based on the Type C specification, and the Type C controller ESD protection.

Reverse Standoff Voltage – This specification is important spec to look at when selecting a TVS, due to the types of signals that will utilize the CC pin during normal operation, as well as absolute maximum spec. of the CC controller IC. Selecting the right value ensures the TVS is actually effective in protecting the system. Reverse Standoff Voltage, V_{RWM} , is a common specification in a TVS product datasheet. For the CC pin, we should pick a 5 V maximum for the V_{RWM} , due to normal operation of the CC pin, there should never be a case where the CC pin should exceed 5 V, and also the reverse standoff voltage should be lower than the absolute maximum voltage on the CC controller IC.

Diode Capacitance – In Power Delivery specification, section 5.8.6, BMC receiver capacitance requirements are shown below in Table 1.

Table 1. BCM Receiver Normative Requirements

Name	Description	Min.	Nom.	Max.	Unit	Comment
cReceiver	CC Receiver Capacitance	200		600	pF	The DFP or UFP system shall have capacitance within this range when not transmitting on the line

The cReceiver requirement of the CC receiver capacitance is 200 pF to 600 pF, this has a direct impact on PD communication. Any device in the CC path, such as a TVS diode, needs to ensure that capacitance of the device does not exceed this specification but can also be used to meet the minimum capacitance requirements. By choosing the appropriate TVS that works well in the system, you can avoid placing additional capacitance on the CC line by utilizing just the diode capacitance.

Breakdown Voltage – Breakdown voltage is the voltage threshold where the TVS diode becomes more conductive to ground and allows higher amount of current flow from cathode to anode. Figure 1 shows a typical TVS I-V curve, and as we can see after the V_{BR} , the current shot up very quickly as the TVS became very conductive. The voltage increases until it hits the clamping voltage where the TVS effectively becomes a resistor that shorts to ground. With a large amount of current passing through the TVS, it will eventually burn up and destroy the diode in this clamped state.

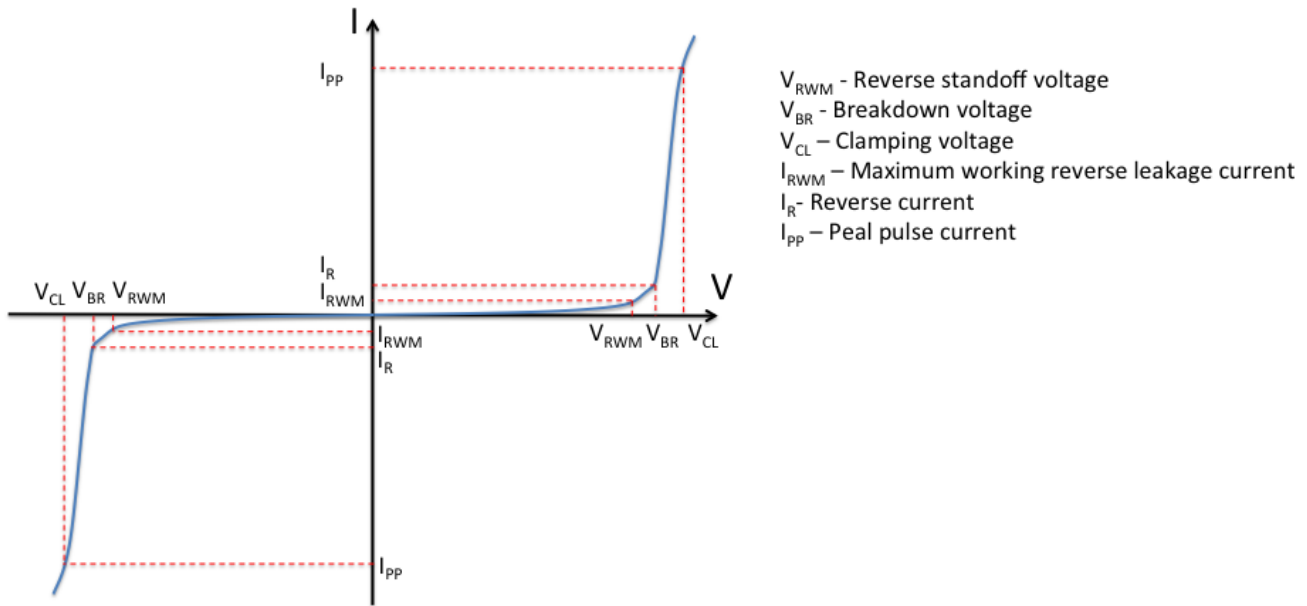

Figure 1. TVS I-V Curve

In order to make sure proper function of the type C CC line communication, and overall system are protected in ESD/Surge event, the correct breakdown voltage must be considered. In type C design, the CC pin break down voltage should be above 5 V to ensure normal operation, and below 7 V to ensure that the TVS can help direct extra charge to ground when fault occurs.

Design Consideration – None USB Standard Charging Protocol

Standard USB2.0 spec. of 500 mA charging current is clearly not enough for the majority of the devices in the market today, power/process intensive devices such as

mobile phones have implemented higher than standard USB2.0 charging protocol to allow for shorter and faster charging. Due to the limitation of the USB cable it is not ideal to push more than 2.4 A of current. In order to be able to charge at higher wattage, non-Type-C connector based designs have gone above 5 V on VBUS to reduce charging time of the device. Due to backward compatibility support of Type C, the Type C specification allows legacy adapters like a Type A to Type C Cable. The type A to type C and Type C to USB- μ B cable integrate an internal pull up resistor (R_p) in the cable. Below is a functional model in the specification 4.5.3.2.4.

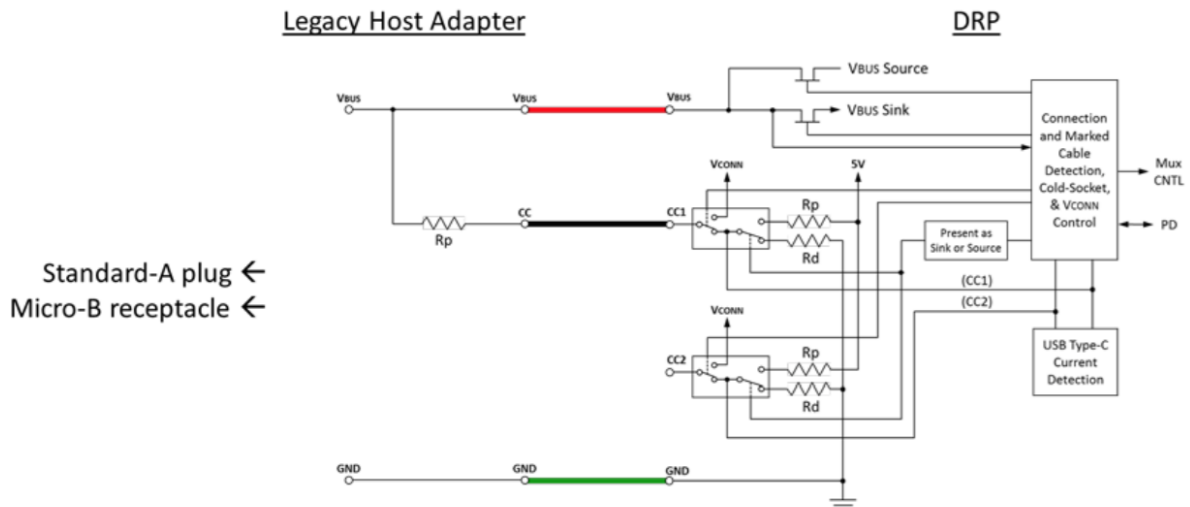

Figure 2. Legacy Host Port to DRP Functional Model

In this case when the non-standard USB charging protocol increases the VBUS voltage level, the CC pin will also be pulled up due to R_p . When following the Type C specification, the R_p value should be 56 k Ω , which means

there will be two cases of higher than normal voltage present on the CC line.

Case 1 – Rd is Enabled

We can simply calculate the voltage that will show up on the CC line with equation (1).

$$V_{CC} = V_{BUS} * 0.0835 \quad (1)$$

Assume $R_d = 5.1 \text{ k}\Omega$, $R_p = 56 \text{ k}\Omega$

In Table 2 we can find the typical V_{BUS} voltage of non-standard charging protocol and its corresponding CC voltage.

Table 2. V_{BUS} to CC Voltage when Rd Enabled

V_{BUS}	V_{CC}
9 V	0.75 V
12 V	1.00 V
15 V	1.25 V
20 V	1.67 V

Table 2 shows that voltage on CC line is still relatively low, so there is no high voltage concern for this case.

Case 2 – Rd is Disabled

With R_d disabled, the CC line will be pulled high to V_{BUS} voltage, so in this case high voltage will show up on the CC line, thus protection is needed. However, since the current is limited by the $56 \text{ k}\Omega$ we can use the Zener diode to clamp the voltage down. We will discuss how to select the correct Zener in the next section. If the proper Zener diode is selected, it can also protect against Illegal Type A to Type C cables with incorrect R_p .

Case 3 – Rapid Insert and Removal of Cable

Some non-standard USB legacy chargers achieve faster charging time by increasing the V_{BUS} voltage. In certain cases, when a user unplugs the device from the charger/host adapter and cable, while the system is charging at higher than 5 V, there will be a short time period for the charger to recognize disconnect event and disable the V_{BUS} supply. During this time, if the R_p is still connected to V_{BUS} , and since it is no longer connected to the device, the residual charge will bring the CC pin to the same voltage as V_{BUS} and slowly discharge over time. If the user decides to quickly plug the charger back in, there will be a higher than normal voltage on the CC pin that we would need to consider. However, in this case the time duration is very short, and the charge remaining on the CC pin is not very large. Incorporating a protection device like a Zener diode or TVS diode in the system can prevent damages to the system.

Design Consideration – Illegal Type A to Type C Cable

The support of existing standard A connectors/host adapters was achieved with a Type A to Type C cable shown in Figure 3. Although, the Type C Specification is public, there are still a lot of bad cables with illegal R_p resistors made and being sold on the market today. Application note [AN-6012](#) explains in detail the bad/illegal cable and how to utilize the Zener diode to protect against it, as well as how to pick the right Zener diode to use.



Figure 3. Example of Type A to Type C Cable

Related Resources

[FUSB301—Datasheet Brief](#)

[FUSB301A—Autonomous USB Type-C Control with Configurable I²C Address](#)

[FUSB302—Programmable USB Type-C Controller w/PD](#)

[AN-6102 – USB Type C, CC Pin Protection Application Note](#)

[AN-6105 – USB Type –C Design Considerations](#)

DISCLAIMER

FAIRCHILD SEMICONDUCTOR RESERVES THE RIGHT TO MAKE CHANGES WITHOUT FURTHER NOTICE TO ANY PRODUCTS HEREIN TO IMPROVE RELIABILITY, FUNCTION, OR DESIGN. FAIRCHILD DOES NOT ASSUME ANY LIABILITY ARISING OUT OF THE APPLICATION OR USE OF ANY PRODUCT OR CIRCUIT DESCRIBED HEREIN; NEITHER DOES IT CONVEY ANY LICENSE UNDER ITS PATENT RIGHTS, NOR THE RIGHTS OF OTHERS.

LIFE SUPPORT POLICY

FAIRCHILD'S PRODUCTS ARE NOT AUTHORIZED FOR USE AS CRITICAL COMPONENTS IN LIFE SUPPORT DEVICES OR SYSTEMS WITHOUT THE EXPRESS WRITTEN APPROVAL OF THE PRESIDENT OF FAIRCHILD SEMICONDUCTOR CORPORATION.

As used herein:

1. Life support devices or systems are devices or systems which, (a) are intended for surgical implant into the body, or (b) support or sustain life, or (c) whose failure to perform when properly used in accordance with instructions for use provided in the labeling, can be reasonably expected to result in significant injury to the user.
2. A critical component is any component of a life support device or system whose failure to perform can be reasonably expected to cause the failure of the life support device or system, or to affect its safety or effectiveness.

ON Semiconductor and  are trademarks of Semiconductor Components Industries, LLC dba ON Semiconductor or its subsidiaries in the United States and/or other countries. ON Semiconductor owns the rights to a number of patents, trademarks, copyrights, trade secrets, and other intellectual property. A listing of ON Semiconductor's product/patent coverage may be accessed at www.onsemi.com/site/pdf/Patent-Marking.pdf. ON Semiconductor reserves the right to make changes without further notice to any products herein. ON Semiconductor makes no warranty, representation or guarantee regarding the suitability of its products for any particular purpose, nor does ON Semiconductor assume any liability arising out of the application or use of any product or circuit, and specifically disclaims any and all liability, including without limitation special, consequential or incidental damages. Buyer is responsible for its products and applications using ON Semiconductor products, including compliance with all laws, regulations and safety requirements or standards, regardless of any support or applications information provided by ON Semiconductor. "Typical" parameters which may be provided in ON Semiconductor data sheets and/or specifications can and do vary in different applications and actual performance may vary over time. All operating parameters, including "Typicals" must be validated for each customer application by customer's technical experts. ON Semiconductor does not convey any license under its patent rights nor the rights of others. ON Semiconductor products are not designed, intended, or authorized for use as a critical component in life support systems or any FDA Class 3 medical devices or medical devices with a same or similar classification in a foreign jurisdiction or any devices intended for implantation in the human body. Should Buyer purchase or use ON Semiconductor products for any such unintended or unauthorized application, Buyer shall indemnify and hold ON Semiconductor and its officers, employees, subsidiaries, affiliates, and distributors harmless against all claims, costs, damages, and expenses, and reasonable attorney fees arising out of, directly or indirectly, any claim of personal injury or death associated with such unintended or unauthorized use, even if such claim alleges that ON Semiconductor was negligent regarding the design or manufacture of the part. ON Semiconductor is an Equal Opportunity/Affirmative Action Employer. This literature is subject to all applicable copyright laws and is not for resale in any manner.

PUBLICATION ORDERING INFORMATION

LITERATURE FULFILLMENT:

Literature Distribution Center for ON Semiconductor
19521 E. 32nd Pkwy, Aurora, Colorado 80011 USA
Phone: 303-675-2175 or 800-344-3860 Toll Free USA/Canada
Fax: 303-675-2176 or 800-344-3867 Toll Free USA/Canada
Email: orderlit@onsemi.com

N. American Technical Support: 800-282-9855 Toll Free
USA/Canada
Europe, Middle East and Africa Technical Support:
Phone: 421 33 790 2910
Japan Customer Focus Center
Phone: 81-3-5817-1050

ON Semiconductor Website: www.onsemi.com
Order Literature: <http://www.onsemi.com/orderlit>
For additional information, please contact your local
Sales Representative